

PARTS CATALOGUE



BLUE



RED

MTT850D (B0S2) MALAYSIA *TRACER 900GT*

MTT850D
PARTS CATALOGUE
©2018 by Yamaha Motor Co., Ltd.
1st edition, November 2018
All rights reserved.
Any reprinting or unauthorized use
without the written permission of
Yamaha Motor Co., Ltd.
is expressly prohibited.
Printed in Japan.

FOREWORD

This Parts Catalogue is related to the parts for the model(s) on the cover page. When you are ordering replacement parts, please refer to this Parts Catalogue and quote both part numbers and part names correctly.

1. Modifications or additions which have been made after the issue of the Parts Catalogue will be announced in the Parts News.
It is advisable that you make the necessary corrections to the Parts Catalogue according to the Parts News.

2. Abbreviations

The following abbreviations are used in this Parts Catalogue.

“UR” Use specified parts number.

“UN” Use as many as needed.

“AP” Alternate Parts

“LM” Locally Made (Parts need to be ordered locally)

“F#” Frame No. (Applicable machine No.)

“O/S” Over Size

3. The number of components for assembly

- Parts, which are to be supplied in an assembly, are listed with a dot (.) in front of the part name as shown below.
- The numeral appearing to the right of each component part indicates the quantity of parts for each assembly unit.

PART NO.	DESCRIPTION	Q'TY	REMARKS
2F5-83310-60	FRONT FLASHER LIGHT ASSY	2	
115-83311-60	.BULB (6V-18W)	1	

4. Applicable colours of graphics are represented in the “REMARKS” as shown below.

PART NO.	DESCRIPTION	Q'TY	REMARKS
2N4-24110-00-X5	FUEL TANK COMP.	2	MXR
3J1-24240-10	.GRAPHIC, FUEL TANK	1	FOR MXR

5. Note that the illustrations for reference in finding parts numbers are not to be used for assembling. When assembling, please use the applicable service manual.

6. The asterisk (*) before a reference number indicates modified items after the first edition.

FOREWORD

7. Applicable Serial No.

Frame Serial No.

Engine Serial No.

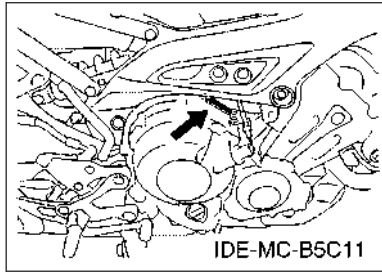
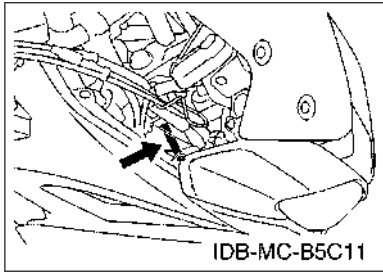

8. Applicable Colour Code (The (*) mark shows Model colour.)

Abbreviation	Colour Name	Colour Code
BNS4(*)	BLUISH GRAY SOLID 4	1511
DRMK	DEEP RED METALLIC K	0918
LGB	LOW GLOSS BLACK	0098
MBL2	MAT BLACK 2	0582
MDPBM1(*)	MAT DARK PURPLISH BLUE ME 1	1595
MLNM3	MAT LIGHT GRAY METALLIC 3	1553

9. Applicable Starting Serial No.

Frame Serial No.

Serial No.	Name Of Q'ty Column	Model Code

Engine Serial No.

Serial No.	Name Of Q'ty Column	Model Code

CONTENTS

ENGINE

CYLINDER HEAD.....	1
CRANKSHAFT & PISTON.....	3
VALVE.....	4
CAMSHAFT & CHAIN.....	6
WATER PUMP.....	7
RADIATOR & HOSE.....	9
OIL PUMP.....	11
OIL CLEANER.....	12
INTAKE.....	13
INTAKE 2.....	14
AIR INDUCTION SYSTEM.....	16
EXHAUST.....	17
CRANKCASE.....	18
CRANKCASE COVER 1.....	20
STARTER.....	22
CLUTCH.....	23
TRANSMISSION.....	25
SHIFT CAM & FORK.....	27
SHIFT SHAFT.....	28

CHASSIS

FRAME.....	30
FENDER.....	31
SIDE COVER.....	33
REAR ARM.....	34
REAR SUSPENSION.....	36
STEERING.....	37
FRONT FORK.....	38
FUEL TANK.....	40
SEAT.....	43
FRONT WHEEL.....	45
FRONT BRAKE CALIPER.....	46
REAR WHEEL.....	48
REAR BRAKE CALIPER.....	50
STEERING HANDLE & CABLE.....	51
FRONT MASTER CYLINDER.....	53
STAND & FOOTREST.....	55
REAR MASTER CYLINDER.....	58
WINDSHIELD.....	60

COWLING.....	61
GENERATOR.....	64
STARTING MOTOR.....	65
FLASHER LIGHT.....	66
METER.....	67
HEADLIGHT.....	68
TAILLIGHT.....	69
HANDLE SWITCH & LEVER.....	70
ELECTRICAL 1.....	71
ELECTRICAL 2.....	73
ELECTRICAL 3.....	74

INDEX

NUMERICAL INDEX.....	75
----------------------	----

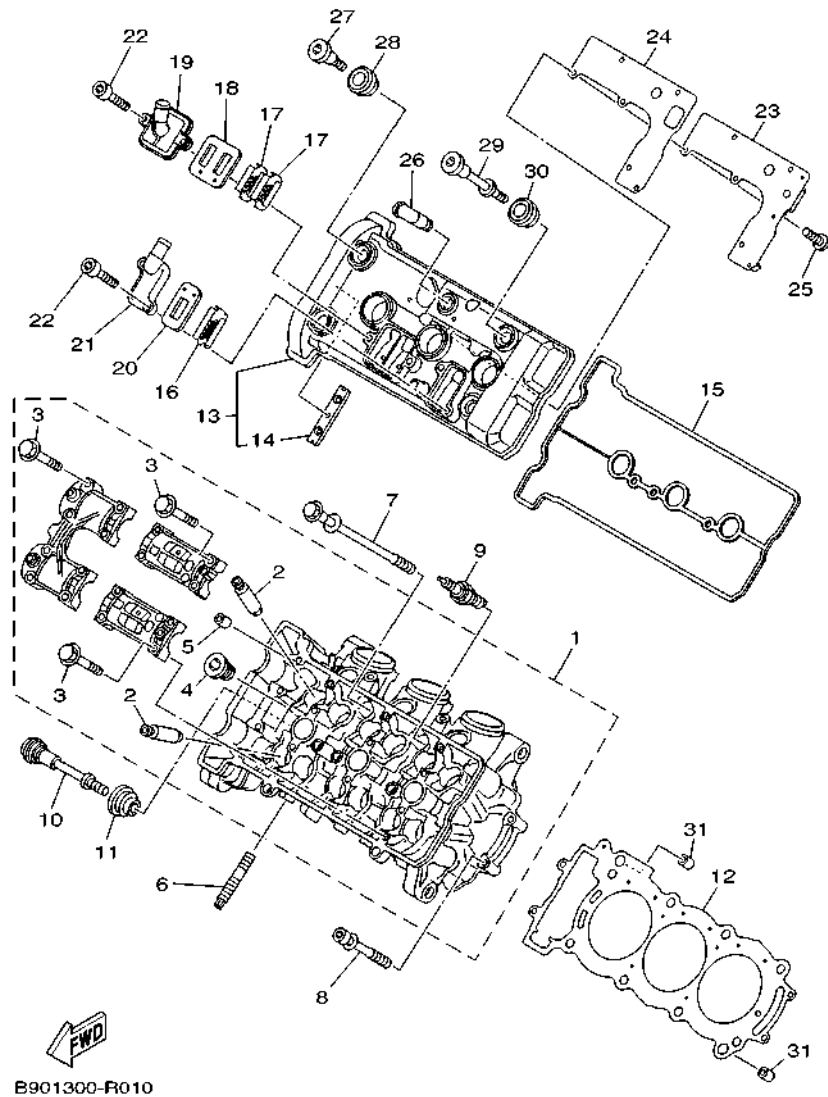

B901300-R010

FIG. 1 CYLINDER HEAD

REF. NO.	PART NO.	DESCRIPTION	BOS2				REMARKS
1	B90-11101-09	CYLINDER HEAD ASSY	1				
2	2C0-11133-11	.GUIDE, VALVE 1	12				
3	90105-06027	.BOLT, FLANGE	16				
4	90340-18002	.PLUG, STRAIGHT SCREW	2				
5	91808-16023	.PIN, DOWEL	6				
6	90116-08087	BOLT, STUD	6				
7	90119-09017	BOLT, WITH WASHER	8				
8	90109-061F7	BOLT	4				
9	94701-00431	PLUG, SPARK (NGK R CPR9EA-9)	3				
10	90109-06293	BOLT	1				
11	5VY-1111G-00	RUBBER, MOUNT 1	1				
12	BS2-11181-00	GASKET, CYLINDER HEAD 1	1				
13	1RC-11191-00	COVER, CYLINDER HEAD 1	1				
14	5BE-12241-00	.GUIDE, STOPPER 2	1				
15	1RC-11193-01	GASKET, HEAD COVER 1	1				
16	5JW-1482K-01	PLATE	1				
17	5VY-1482K-00	PLATE	2				
18	5SL-14890-00	REED VALVE ASSY	1				
19	5SL-14899-00	CAP, CASE	1				
20	5PS-14890-00	REED VALVE ASSY	1				
21	5JW-14889-00	CAP, CASE	1				
22	90110-06175	BOLT, HEXAGON SOCKET HEAD	4				
23	B90-11165-00	PLATE, BREATHER	1				
24	1RC-11169-00	GASKET, BREATHER COVER	1				
25	90149-05037	SCREW	5				
26	BD5-11167-00	PIPE, BREATHER 2	1				
27	90109-066F0	BOLT	3				

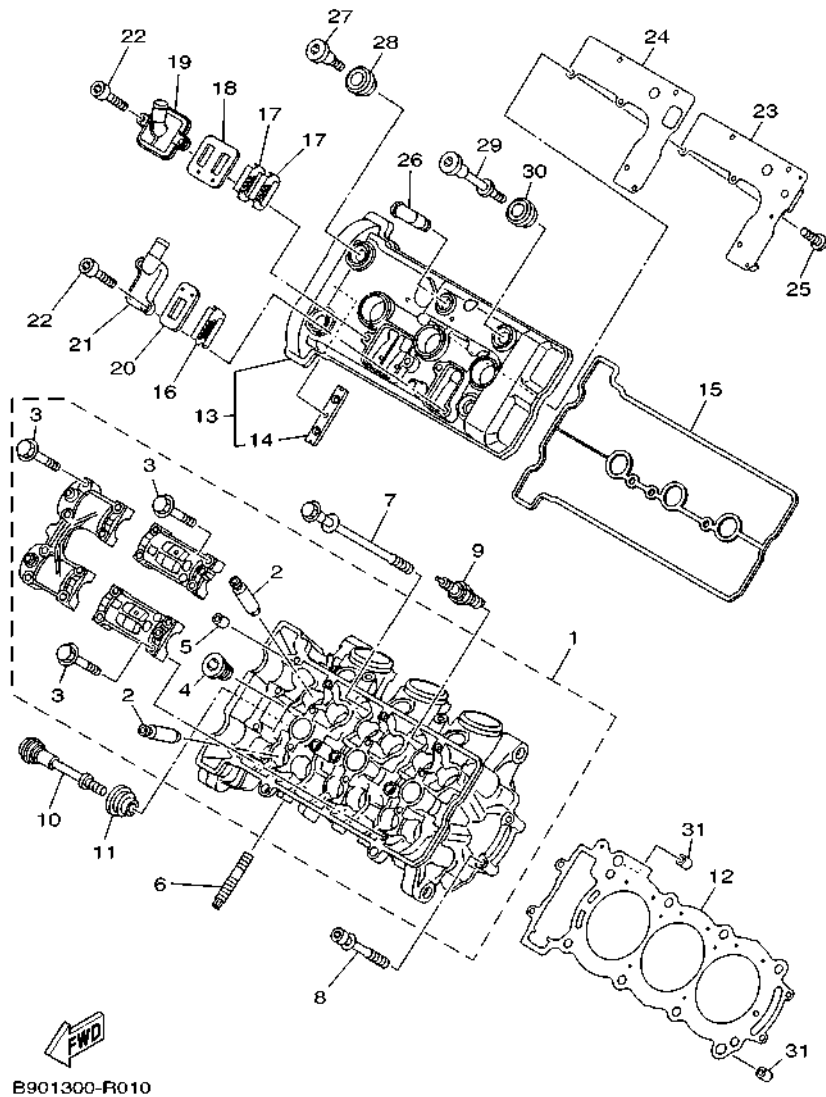

B901300-R010

FIG. 1 CYLINDER HEAD

REF. NO.	PART NO.	DESCRIPTION	BOS2				REMARKS
28	5VY-1111G-00	RUBBER, MOUNT 1	3				
29	90109-06271	BOLT	1				
30	5VY-1111G-00	RUBBER, MOUNT 1	1				
31	99530-12016	PIN, DOWEL	2				

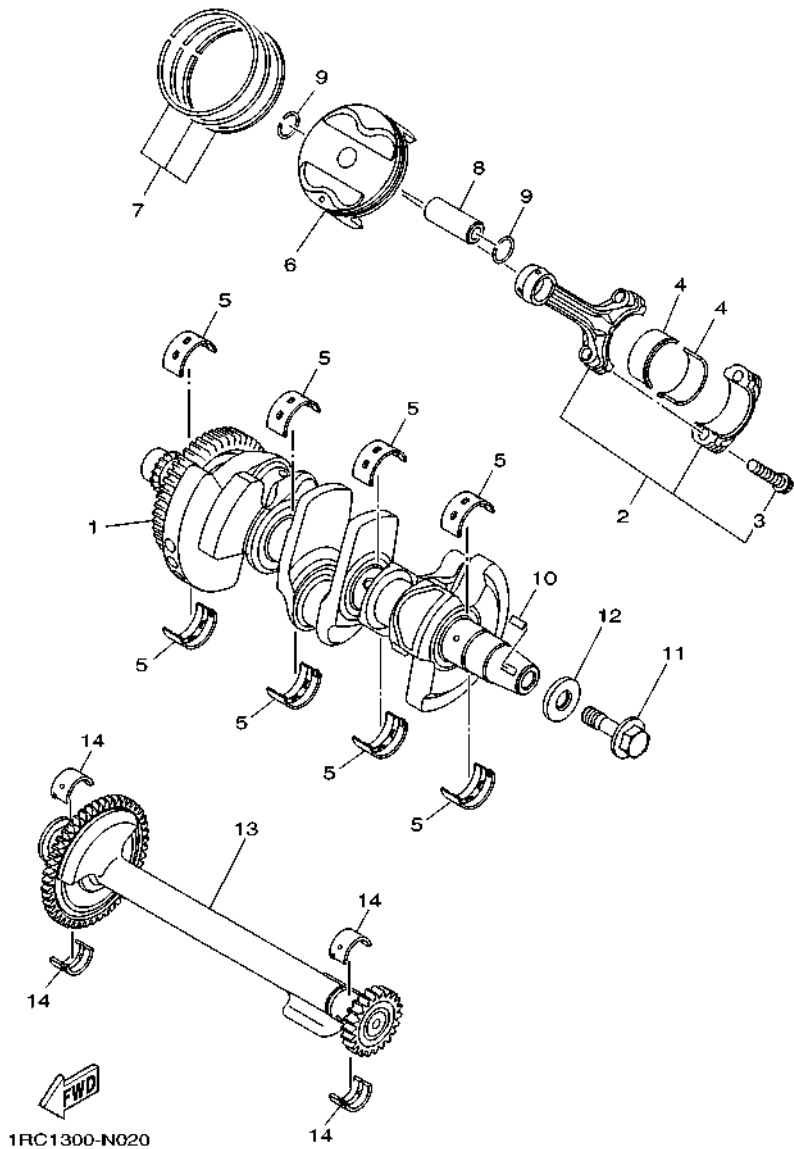
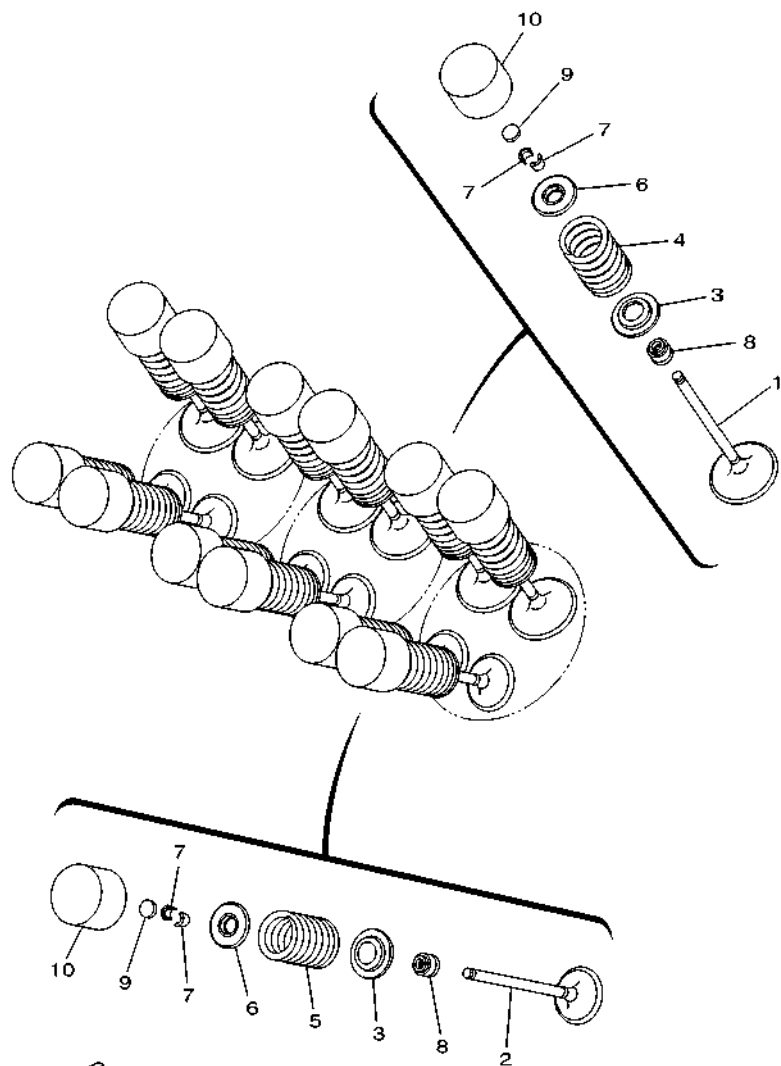

FIG. 2 CRANKSHAFT & PISTON

REF. NO.	PART NO.	DESCRIPTION	BOS2	REMARKS
1	1RC-11400-00	CRANKSHAFT ASSY	1	
2	1RC-11650-01	CONNECTING ROD ASSY	3	
3	1RC-11654-00	.BOLT, CONNECTING ROD	2	
4	1RC-11656-00	PLANE BEARING, CONNECTING ROD	6	UR BLUE
	1RC-11656-10	PLANE BEARING, CONNECTING ROD	6	UR BLACK
	1RC-11656-20	PLANE BEARING, CONNECTING ROD	6	UR BROWN
	1RC-11656-30	PLANE BEARING, CONNECTING ROD	6	UR GREEN
5	5VY-11416-A0	PLANE BEARING, CRANKSHAFT 1	8	UR WHITE
	5VY-11416-00	PLANE BEARING, CRANKSHAFT 1	8	UR BLUE
	5VY-11416-10	PLANE BEARING, CRANKSHAFT 1	8	UR BLACK
	5VY-11416-20	PLANE BEARING, CRANKSHAFT 1	8	UR BROWN
	5VY-11416-30	PLANE BEARING, CRANKSHAFT 1	8	UR GREEN
6	1RC-11631-00	PISTON (STD)	3	
7	1RC-11603-00	PISTON RING SET (STD)	3	
8	39P-11633-00	PIN, PISTON	3	
9	93450-18157	CIRCLIP	6	
10	90280-05029	KEY, WOODRUFF	1	
11	90105-126A8	BOLT, FLANGE	1	
12	90201-12008	WASHER, PLATE	1	
13	1RC-11500-00	BALANCER ASSY	1	
14	2S3-11413-00	METAL, BALANCE WEIGHT	4	UR BLUE
	2S3-11413-10	METAL, BALANCE WEIGHT	4	UR BLACK
	2S3-11413-20	METAL, BALANCE WEIGHT	4	UR BROWN
	2S3-11413-30	METAL, BALANCE WEIGHT	4	UR GREEN
	2S3-11413-40	METAL, BALANCE WEIGHT	4	UR YELLOW



1RC1300-N030

FIG. 3 VALVE

REF. NO.	PART NO.	DESCRIPTION	BOSS	REMARKS
1	1RC-12111-01	VALVE, INTAKE	6	
2	1RC-12121-00	VALVE, EXHAUST	6	
3	1RC-12116-00	SEAT, VALVE SPRING	12	
4	1RC-12113-00	SPRING, VALVE INNER	6	
5	1RC-12114-00	SPRING, VALVE OUTER	6	
6	3D7-12117-00	RETAINER, VALVE SPRING	12	
7	1WG-12118-00	LOCK, VALVE SPRING RETAINER	24	
8	4TE-12119-00	SEAL, VALVE STEM	12	
9	1HX-12168-F0	PAD, ADJUSTING 2 (1.50)	12	UR
	1HX-12168-H1	PAD, ADJUSTING 2 (1.55)	12	UR
	1HX-12168-K1	PAD, ADJUSTING 2 (1.60)	12	UR
	1HX-12168-M1	PAD, ADJUSTING 2 (1.65)	12	UR
	1HX-12168-R1	PAD, ADJUSTING 2 (1.70)	12	UR
	1HX-12168-U1	PAD, ADJUSTING 2 (1.75)	12	UR
	1HX-12168-W1	PAD, ADJUSTING 2 (1.80)	12	UR
	1HX-12168-Y1	PAD, ADJUSTING 2 (1.85)	12	UR
	1HX-12169-11	PAD, ADJUSTING 2 (1.90)	12	UR
	1HX-12169-31	PAD, ADJUSTING 2 (1.95)	12	UR
	1HX-12169-50	PAD, ADJUSTING 2 (2.00)	12	UR
	1HX-12169-70	PAD, ADJUSTING 2 (2.05)	12	UR
	1HX-12169-90	PAD, ADJUSTING 2 (2.10)	12	UR
	1HX-12169-E0	PAD, ADJUSTING 2 (2.15)	12	UR
	1HX-12169-G0	PAD, ADJUSTING 2 (2.20)	12	UR
	1HX-12169-J0	PAD, ADJUSTING 2 (2.25)	12	UR
	1HX-12169-L0	PAD, ADJUSTING 2 (2.30)	12	UR
	1HX-12169-N0	PAD, ADJUSTING 2 (2.35)	12	UR
	1HX-12169-T0	PAD, ADJUSTING 2 (2.40)	12	UR

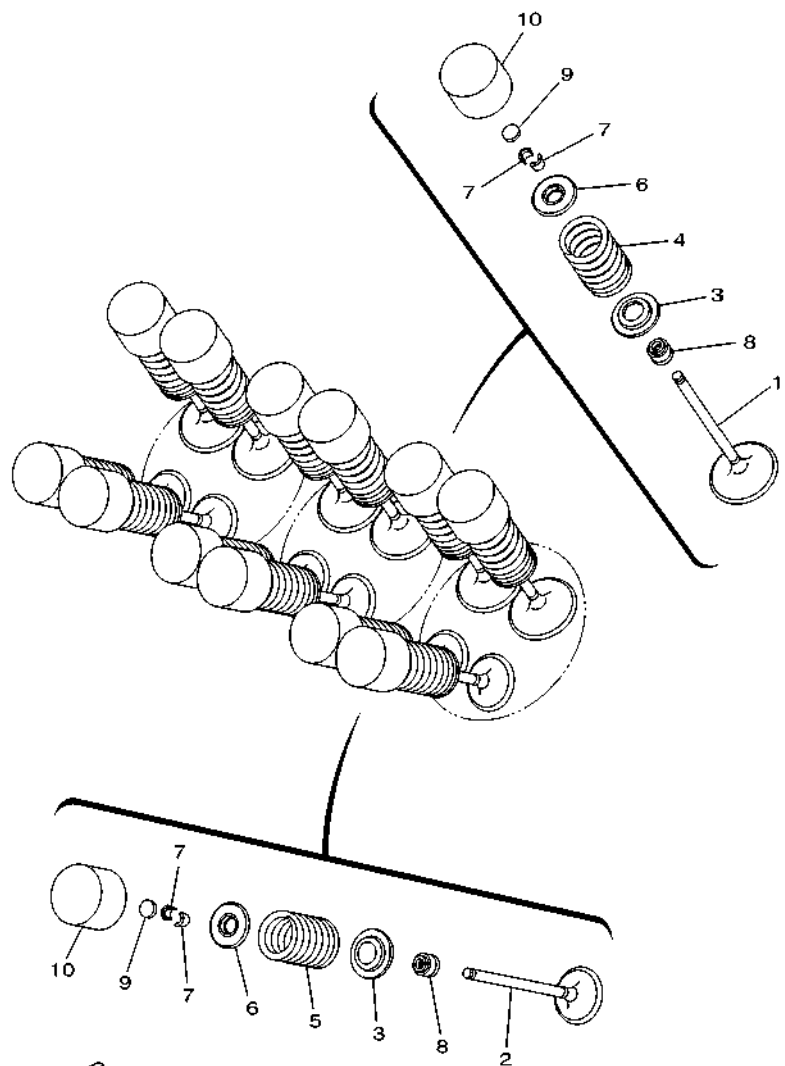



 1RC1300-N030

FIG. 3 VALVE

REF. NO.	PART NO.	DESCRIPTION	BOS2	REMARKS
10	4C8-12153-10	LIFTER, VALVE	12	YELLOW
	4C8-12153-09	LIFTER, VALVE (O/S)	12	AP GREEN

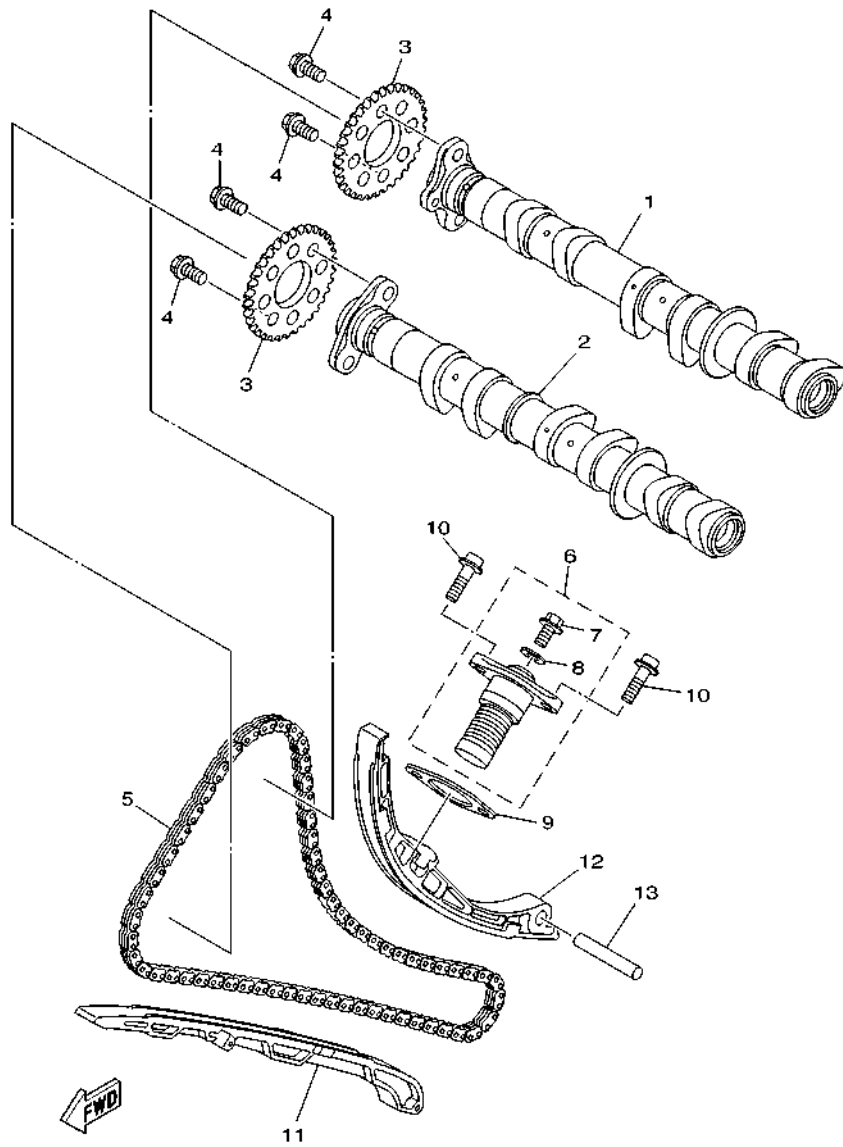
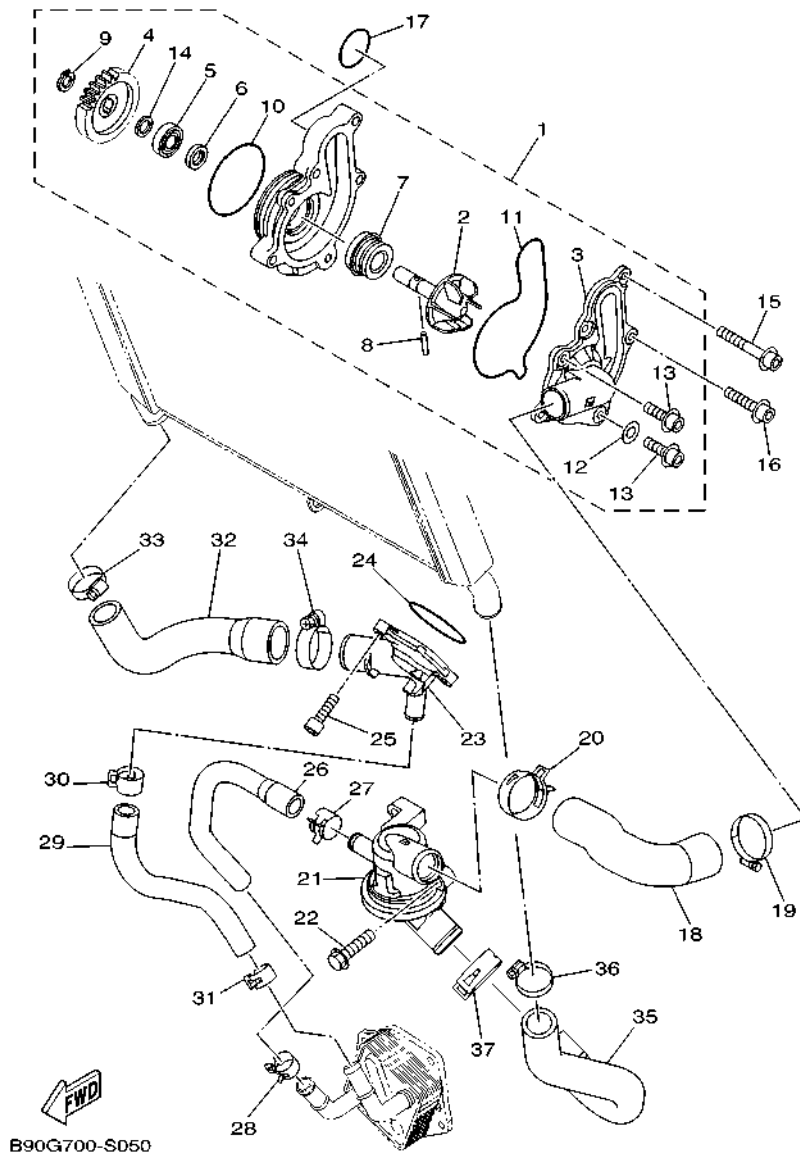

FIG. 4 CAMSHAFT & CHAIN

REF. NO.	PART NO.	DESCRIPTION	BOS2				REMARKS
1	1RC-12170-00	CAMSHAFT ASSY 1	1				
2	1RC-12180-00	CAMSHAFT ASSY 2	1				
3	20S-12176-00	SPROCKET, CAM CHAIN	2				
4	90105-07006	BOLT, FLANGE	4				
5	94591-57128	CHAIN (98XRH2010-128M)	1				
6	B90-12210-00	TENSIONER ASSY, CAM CHAIN	1				
7	5EL-12228-00	.BOLT	1				
8	5SL-12214-00	.GASKET	1				
9	1WS-12213-00	GASKET, TENSIONER CASE	1				
10	90110-06395	BOLT, HEXAGON SOCKET HEAD	2				
11	1RC-12251-00	DAMPER, CHAIN 1	1				
12	1RC-12250-01	CHAIN DAMPER ASSY	1				
13	93607-44002	PIN, DOWEL	1				



B90G700-S050

FIG. 5 WATER PUMP

REF. NO.	PART NO.	DESCRIPTION	BOS2				REMARKS
1	1RC-12420-00	WATER PUMP ASSY	1				
2	1RC-12450-00	.IMPELLER SHAFT ASSY	1				
3	1RC-12422-00	.COVER, HOUSING	1				
4	1RC-12459-00	.GEAR, IMPELLER SHAFT	1				
5	93306-00106	.BEARING	1				
6	93101-12173	.OIL SEAL	1				
7	5VK-12438-00	.SEAL, MECHANICAL	1				
8	93603-16219	.PIN, DOWEL	1				
9	99009-12400	.CIRCLIP	1				
10	93210-61750	.O-RING	1				
11	1RC-12439-00	.O-RING	1				
12	90430-06014	.GASKET	1				
13	90110-06396	.BOLT, HEXAGON SOCKET HEAD	2				
14	90201-12541	.WASHER, PLATE	1				
15	90110-06394	BOLT, HEXAGON SOCKET HEAD	3				
16	90110-06388	BOLT, HEXAGON SOCKET HEAD	1				
17	93210-30694	O-RING	1				
18	1RC-12577-00	HOSE 2	1				
19	90450-38040	HOSE CLAMP ASSY	1				
20	90467-310A0	CLIP	1				
21	1RC-12410-00	THERMOSTAT ASSY	1				
22	95822-06025	BOLT, FLANGE	2				
23	1RC-12469-00	JOINT 1	1				
24	93210-46044	O-RING	1				
25	90110-06274	BOLT, HEXAGON SOCKET HEAD	2				
26	BS2-12578-00	HOSE 3	1				
27	90467-21068	CLIP	1				

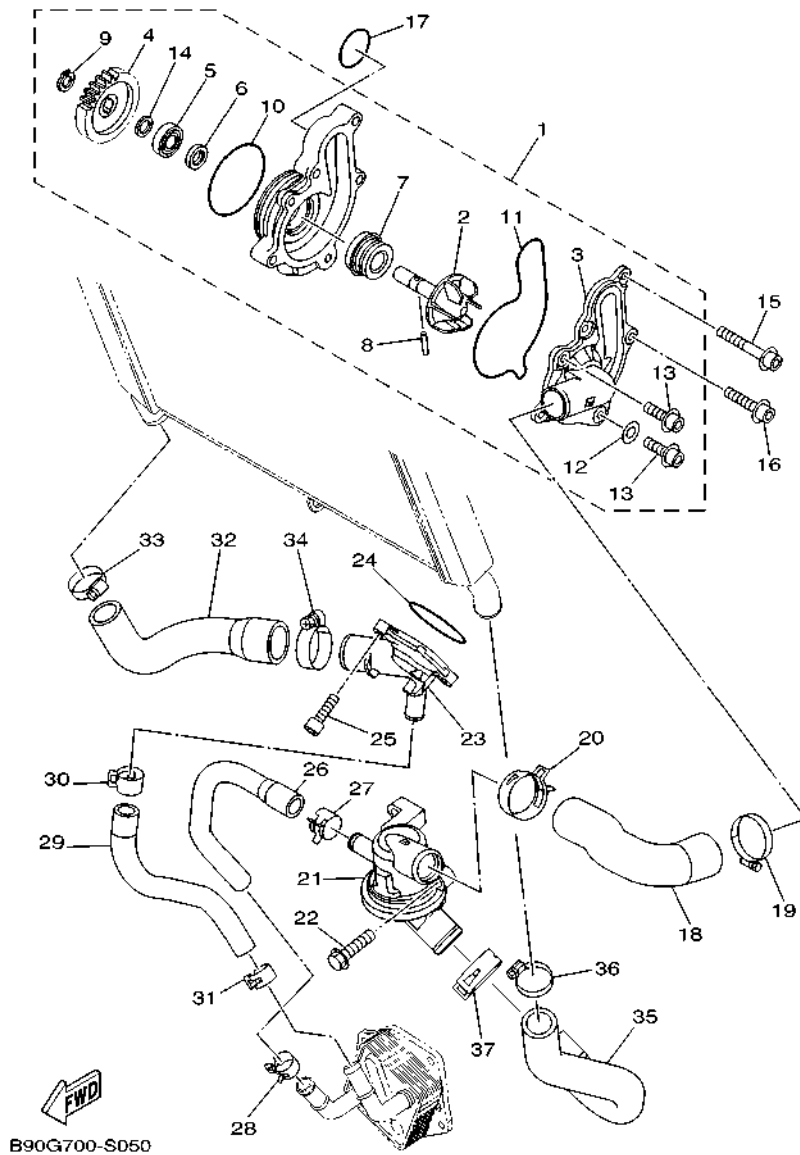
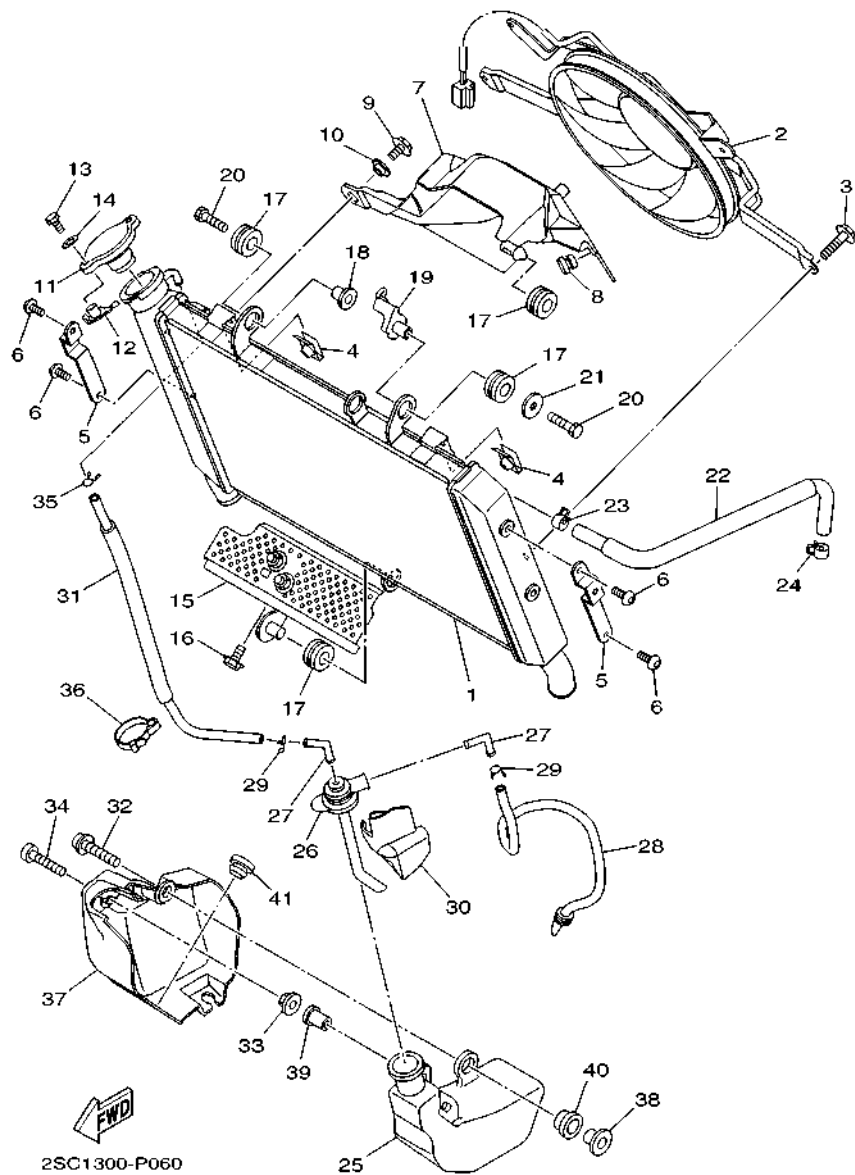

FIG. 5 WATER PUMP

REF. NO.	PART NO.	DESCRIPTION	BOS2				REMARKS
28	90467-200A0	CLIP	1				
29	BS2-12579-00	HOSE 4	1				
30	90467-22002	CLIP	1				
31	90467-200A0	CLIP	1				
32	1RC-12588-00	HOSE 5	1				
33	90450-32003	HOSE CLAMP ASSY	1				
34	90450-38040	HOSE CLAMP ASSY	1				
35	1RC-12576-00	HOSE 1	1				
36	90450-32003	HOSE CLAMP ASSY	1				
37	90467-310A0	CLIP	1				

FIG. 6 RADIATOR & HOSE



REF. NO.	PART NO.	DESCRIPTION	BOS2				REMARKS
1	2PP-12461-00	RADIATOR COMP	1				
2	1RC-12405-01	BLOWER ASSY	1				
3	3D8-12675-00	BOLT, BLOWER HOLDING	4				
4	1AA-12535-00	PLATE	2				
5	2PP-1244E-00	BRACKET 1	2				
6	92012-06010	BOLT, BUTTON HEAD	4				
7	1RC-12467-00	COVER, RADIATOR	1				
8	90338-07157	PLUG	1				
9	90105-06080	BOLT, FLANGE	1				
10	90387-07717	COLLAR	1				
11	4FL-12462-00	CAP, RADIATOR	1				
12	5FC-12437-00	STOPPER	1				
13	97007-05012	BOLT	1				
14	92907-05600	WASHER, PLATE	1				
15	1RC-12637-00	STAY 1	1				
16	95822-06012	BOLT, FLANGE	1				
17	90480-15363	GROMMET	4				
18	90387-06158	COLLAR	1				
19	1RC-26132-00	GUIDE, CABLE 2	1				
20	91312-06030	BOLT, HEXAGON SOCKET HEAD	2				
21	90201-06033	WASHER, PLATE	1				
22	1RC-1243A-00	HOSE 1	1				
23	90467-10039	CLIP	1				
24	90467-10039	CLIP	1				
25	1RC-21871-00	TANK, RECOVERY	1				
26	1RC-21875-00	CAP	1				
27	1RC-21828-00	ELBOW	2				

FIG. 6 RADIATOR & HOSE

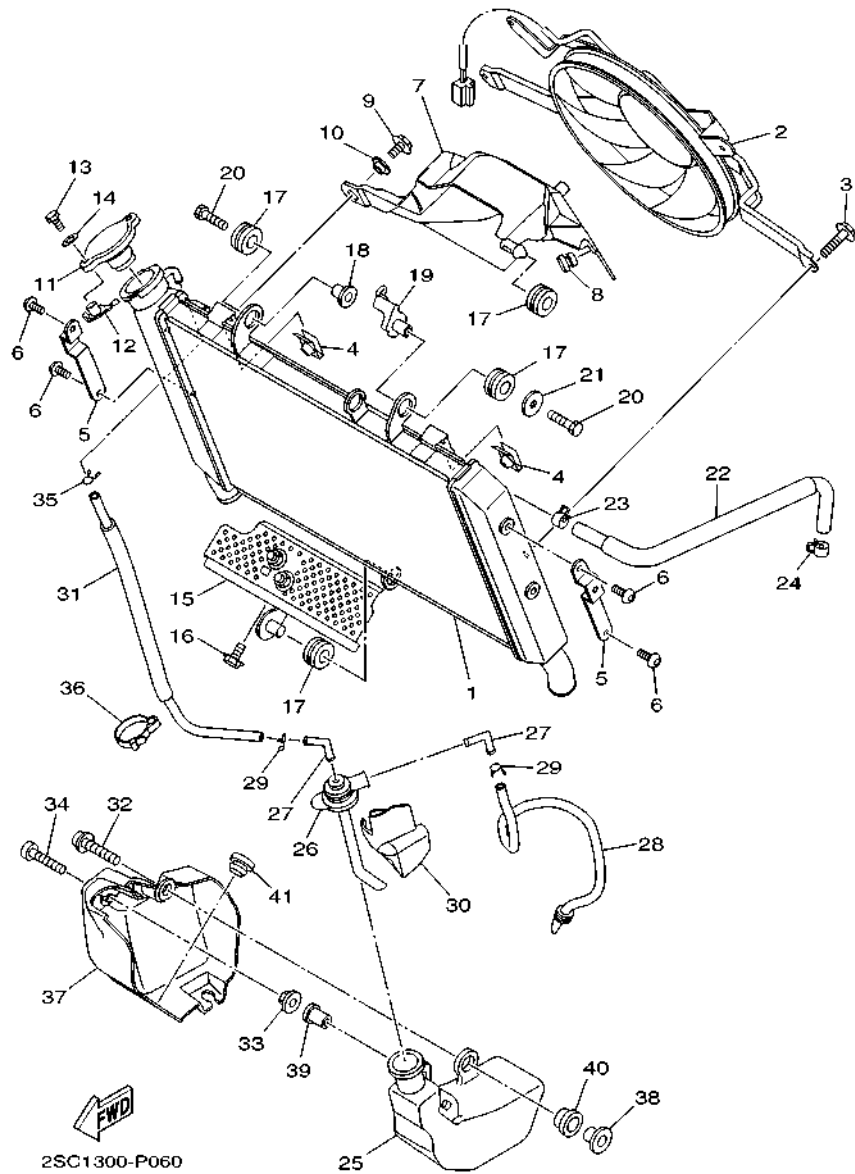

REF. NO.	PART NO.	DESCRIPTION	BOS2				REMARKS
28	1RC-21826-00	PIPE, BREATHER	1				
29	90467-08075	CLIP	2				
30	1RC-22825-00	PROTECTOR 1	1				
31	1RC-21816-00	PIPE 1	1				
32	90110-06233	BOLT, HEXAGON SOCKET HEAD	1				
33	1RC-21748-00	COLLAR	1				
34	92012-05030	BOLT, BUTTON HEAD	1				
35	90467-08075	CLIP	1				
36	90464-07M40	CLAMP	1				
37	1RC-2172W-00	COVER	1				
38	90387-06285	COLLAR	1				
39	90179-05523	NUT	1				
40	1RC-21749-00	COLLAR	1				
41	90480-13203	GROMMET	1				

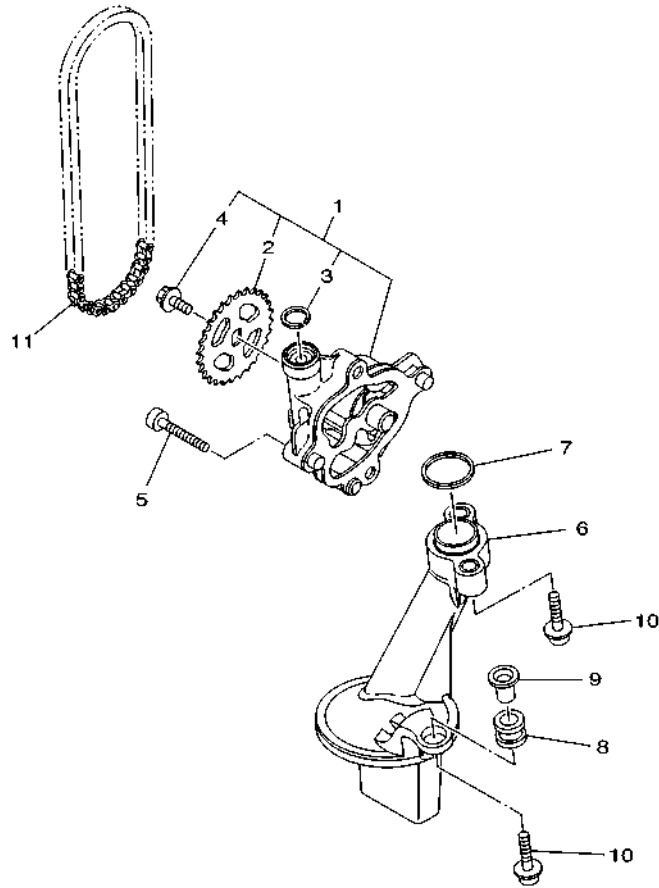
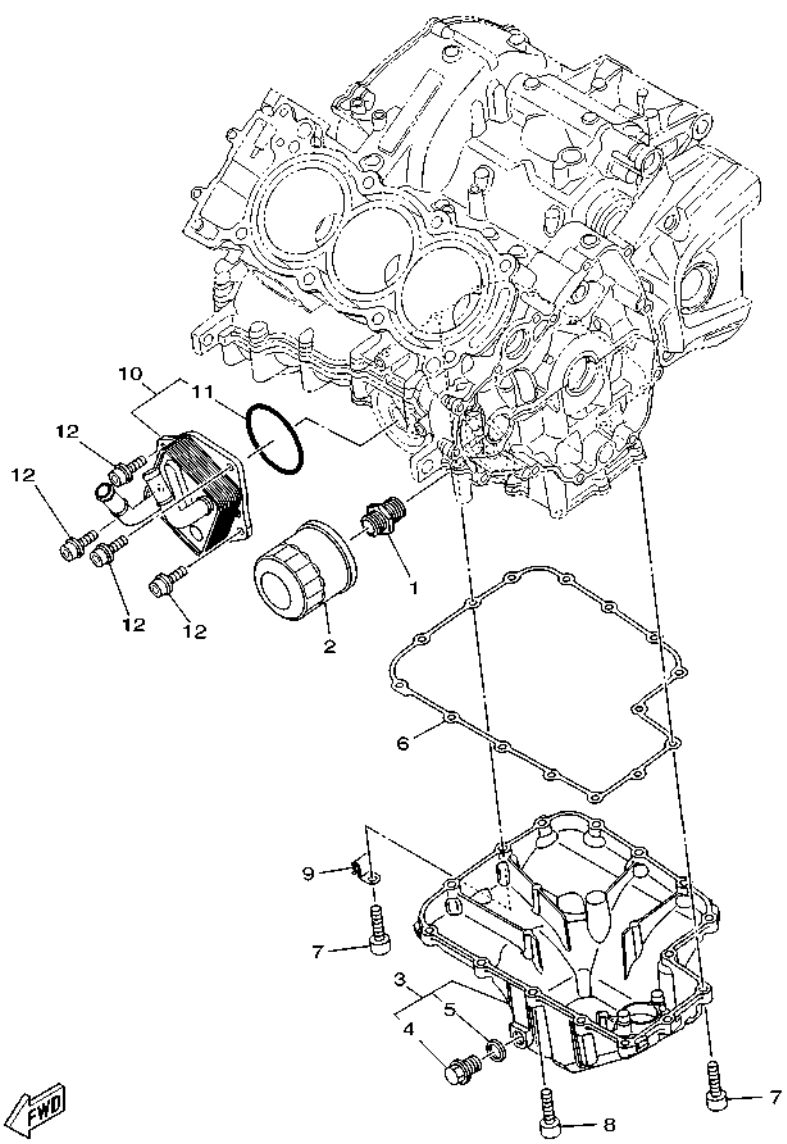

FIG. 7 OIL PUMP

REF. NO.	PART NO.	DESCRIPTION	BOS2				REMARKS
1	1RC-13300-00	OIL PUMP ASSY	1				
2	1RC-13355-00	.SPROCKET, DRIVEN	1				
3	99009-15500	.CIRCLIP	1				
4	90105-06066	.BOLT, FLANGE	1				
5	91312-06035	BOLT, HEXAGON SOCKET HEAD	4				
6	1RC-13410-00	STRAINER HOUSING ASSY	1				
7	93210-22001	O-RING	1				
8	90480-13010	GROMMET	1				
9	5VY-13117-10	COLLAR, DISTANCE	1				
10	90110-06173	BOLT, HEXAGON SOCKET HEAD	3				
11	94581-79066	CHAIN (DID 25H)	1				

 1RC1300-N070



B90G700-S080

FIG. 8 OIL CLEANER

REF. NO.	PART NO.	DESCRIPTION	BOS2				REMARKS
1	90401-20011	BOLT, UNION	1				
2	5GH-13440-60	ELEMENT ASSY, OIL CLEANER	1				
3	B56-13400-10	STRAINER COVER ASSY	1				
4	90340-14132	.PLUG, STRAIGHT SCREW	1				
5	214-11198-01	.GASKET	1				
6	BD5-13414-00	GASKET, STRAINER COVER	1				
7	91312-06025	BOLT, HEXAGON SOCKET HEAD	14				
8	90110-06169	BOLT, HEXAGON SOCKET HEAD	1				
9	90465-06025	CLAMP	1				
10	BS2-13470-00	OIL COOLER ASSY	1				
11	2HC-13473-00	.O-RING	1				
12	90110-06164	BOLT, HEXAGON SOCKET HEAD	4				

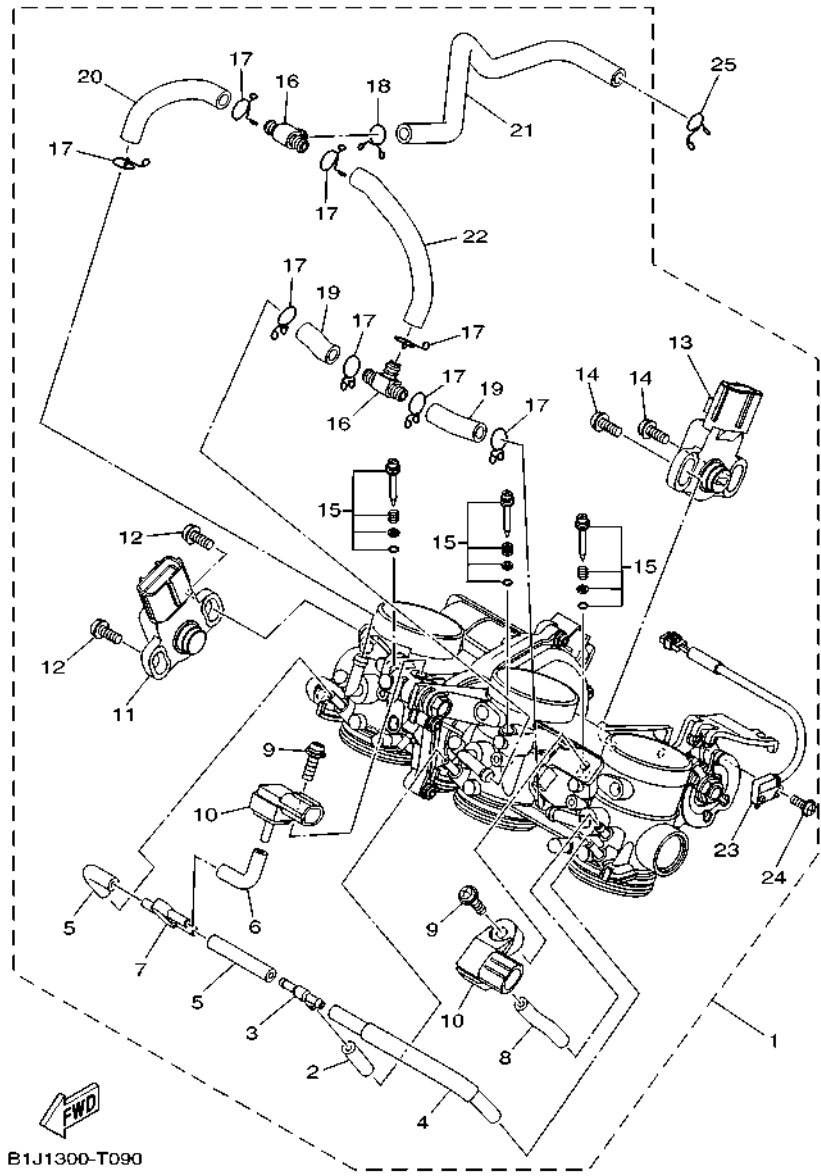
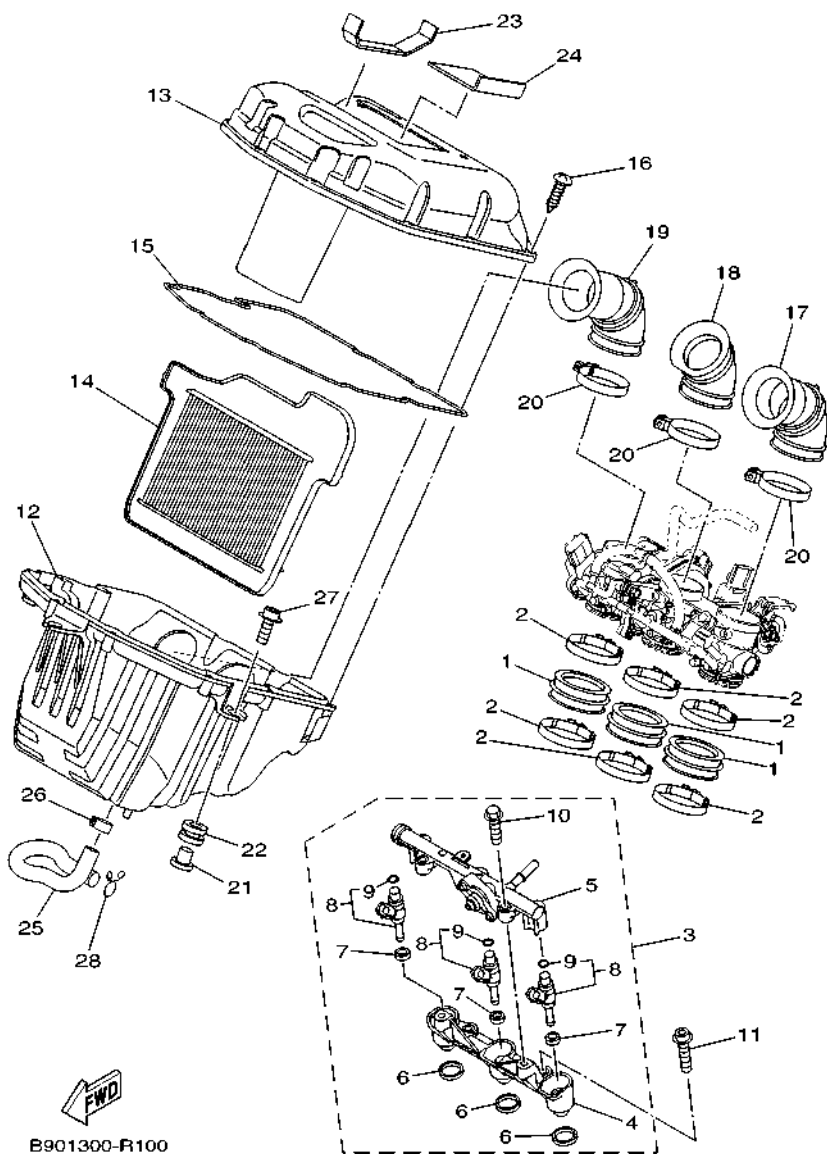

FIG. 9 INTAKE

REF. NO.	PART NO.	DESCRIPTION	BOS2				REMARKS
1	B1J-13750-00	THROTTLE BODY ASSY	1				
2	1RC-13544-00	.HOSE, VACUUM SENSING 2	1				
3	68V-24376-00	.PIPE, JOINT 1	1				
4	1RC-13542-00	.HOSE, VACUUM SENSING 1	1				
5	8FP-14349-20	.PIPE	2				
6	8FP-14349-00	.PIPE	1				
7	3XV-14251-00	.NIPPLE	1				
8	8FP-14349-30	.PIPE	1				
9	2C0-14216-00	.SCREW	2				
10	1WS-82380-00	.SENSOR, PRESSURE	2				
11	13S-85885-00	.THROTTLE SENSOR ASSY	1				
12	8CC-14216-10	.SCREW	2				
13	1MC-85884-00	.ACCELERATOR SENSOR ASSY	1				
14	5FL-14216-00	.SCREW	2				
15	2C0-14105-00	.PILOT SCREW SET	3				
16	90413-06031	.WAY 3	2				
17	90467-100A1	.CLIP	8				
18	90467-09103	.CLIP	1				
19	B50-14465-00	.PIPE	2				
20	60L-24321-00	.PIPE 10	1				
21	B90-1443J-00	.PIPE	1				
22	B50-1444J-00	.PIPE	1				
23	1MC-81860-00	.SWITCH ASSY	1				
24	1MC-14216-00	.SCREW	1				
25	90467-09006	CLIP	1				

FIG. 10 INTAKE 2



REF. NO.	PART NO.	DESCRIPTION	BOS2				REMARKS
1	1RC-13635-00	JOINT, INTAKE 1	3				
2	90450-56009	HOSE CLAMP ASSY	6				
3	1RC-13930-00	PIPE INLET ASSEMBLY	1				
4	1RC-12572-00	.ADAPTER	1				
5	1RC-13938-00	.PIPE	1				
6	1RC-13556-00	.GASKET, MANIFOLD	3				
7	8FP-13556-00	.RUBBER, INJECTOR	3				
8	4C8-13761-00	.INJECTOR	3				
9	5PS-14147-00	..O-RING	1				
10	1RC-13573-00	.BOLT 1	2				
11	90110-06388	BOLT, HEXAGON SOCKET HEAD	2				
12	1RC-14411-00	CASE, AIR CLEANER 1	1				
13	1RC-14421-30	CASE, AIR CLEANER 2	1				
14	1RC-14451-00	ELEMENT, AIR CLEANER	1				
15	1RC-14452-00	SEAL	1				
16	90160-05013	SCREW, ROUND TAPPING	10				
17	1RC-14453-00	JOINT, AIR CLEANER 1	1				
18	1RC-14463-00	JOINT, AIR CLEANER 2	1				
19	1RC-14454-00	JOINT	1				
20	90450-53007	HOSE CLAMP ASSY	3				
21	90387-06205	COLLAR	3				
22	90480-12314	GROMMET	3				
23	1RC-14425-00	DAMPER 1	1				
24	1RC-14426-00	DAMPER 2	1				
25	1RC-15393-00	PIPE, BREATHER 2	1				
26	90467-15001	CLIP	1				
27	90110-06233	BOLT, HEXAGON SOCKET HEAD	3				

FIG. 10 INTAKE 2

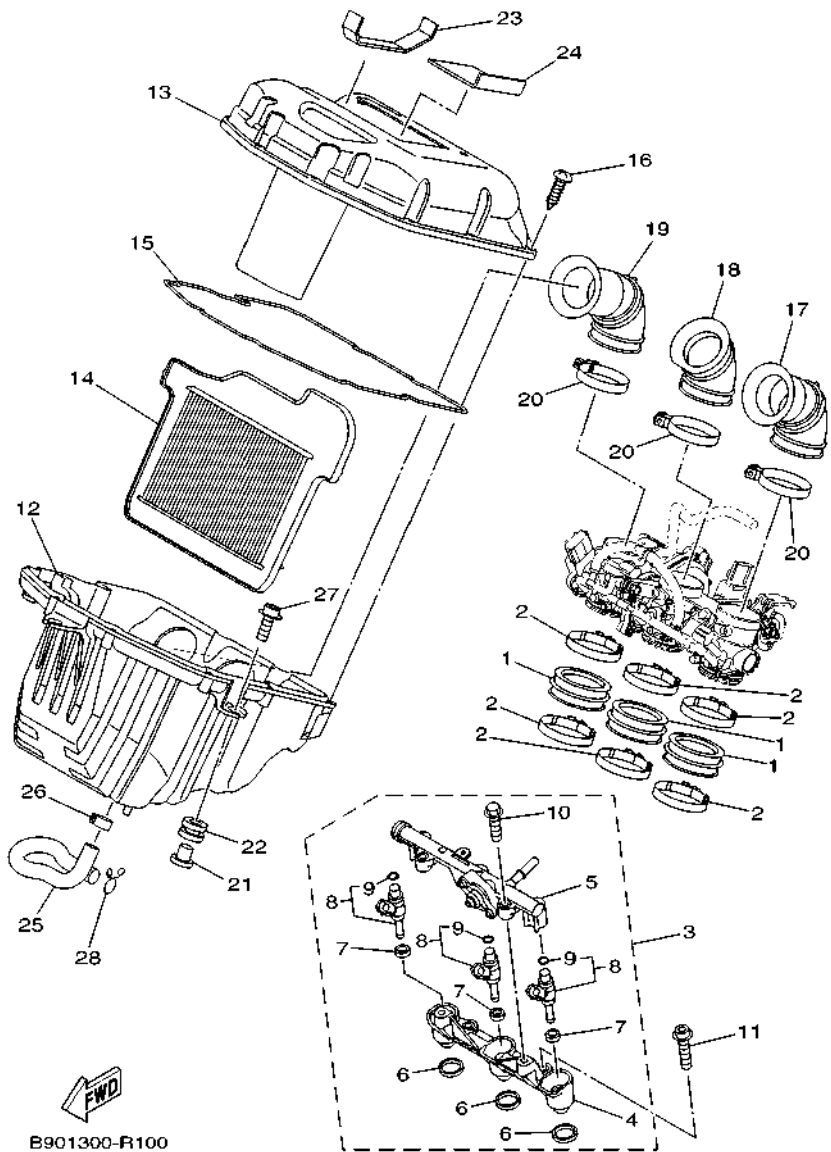

REF. NO.	PART NO.	DESCRIPTION	BOS2					REMARKS
28	90467-14015	CLIP	1					

FIG. 11 AIR INDUCTION SYSTEM

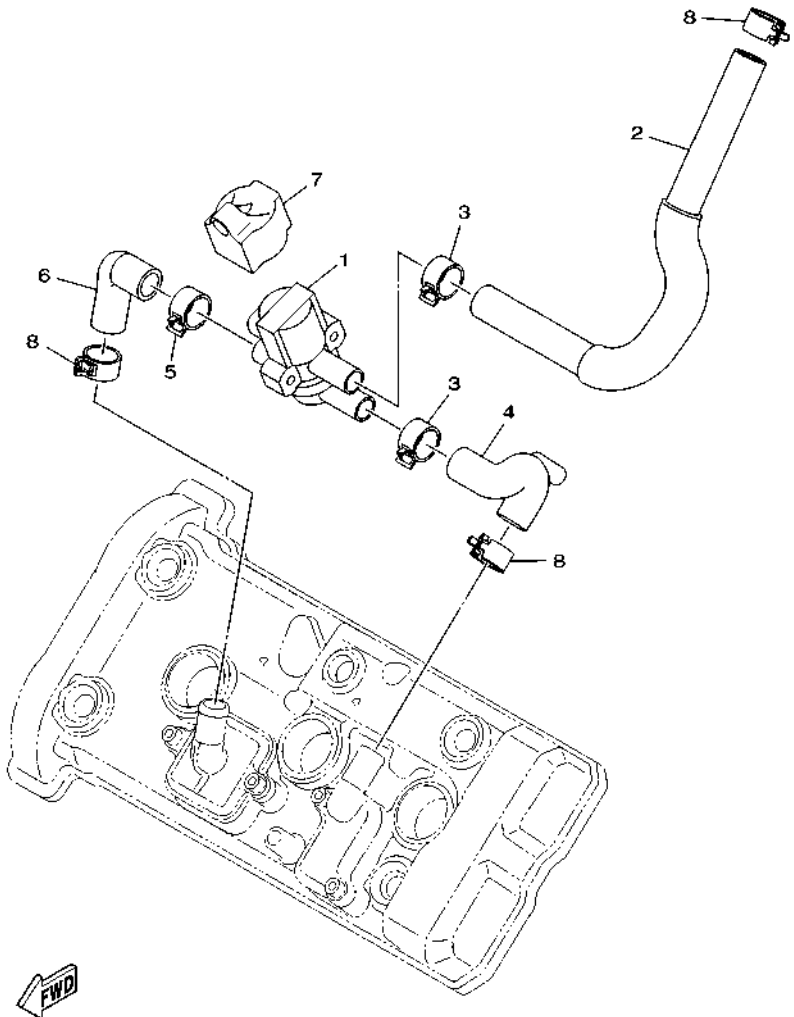

1RC1300-N110

REF. NO.	PART NO.	DESCRIPTION	BOS2				REMARKS
1	2S3-14840-00	AIR CUT VALVE ASSY	1				
2	1RC-14881-00	HOSE, BEND 1	1				
3	90467-17089	CLIP	2				
4	1RC-14882-00	HOSE, BEND 2	1				
5	90467-17089	CLIP	1				
6	1RC-14883-00	HOSE, BEND 3	1				
7	1RC-1445C-00	HOLDER	1				
8	90467-17003	CLIP	3				

FIG. 12 EXHAUST

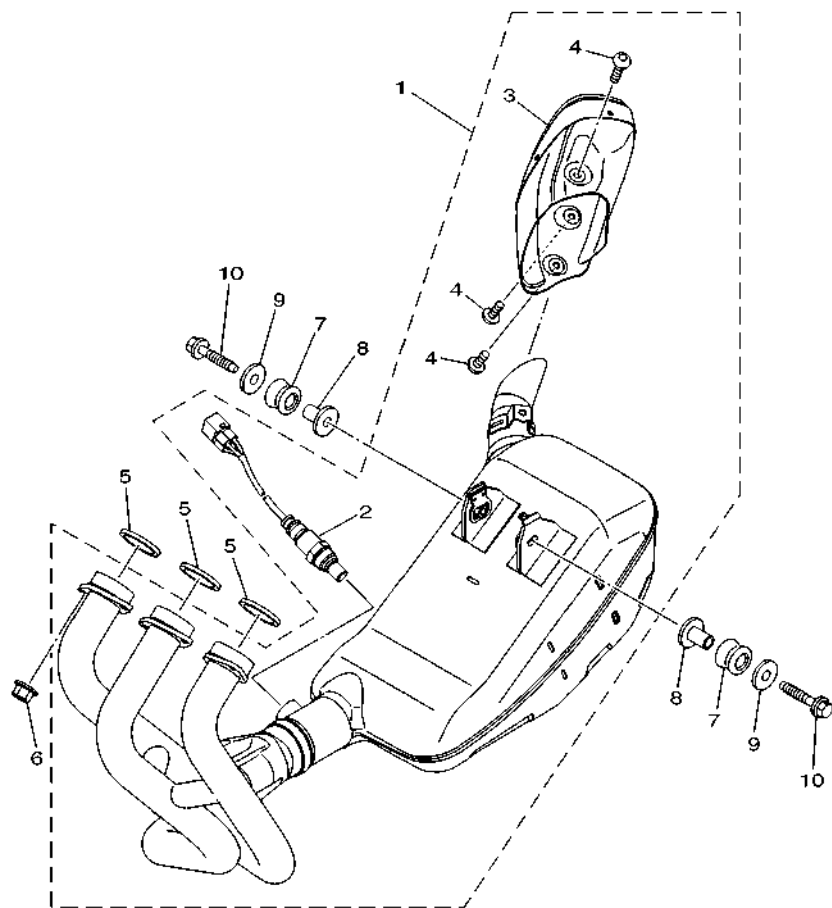

FWD
2SC1300-P120

REF. NO.	PART NO.	DESCRIPTION	BOS2				REMARKS
1	2PP-14710-00	MUFFLER ASSY 1	1				
2	59C-8592A-00	.SENSOR, OXYGEN	1				
3	2PP-14708-00	.PROTECTOR ASSY	1				
4	90111-06060	.BOLT HEX. SOCKET BUTTON	3				
5	4FM-14613-00	GASKET, EXHAUST PIPE	3				
6	90179-08410	NUT	6				
7	5VY-14747-00	DAMPER, MUFFLER	2				
8	90387-08021	COLLAR	2				
9	90201-087G2	WASHER, PLATE	2				
10	90109-08170	BOLT	2				

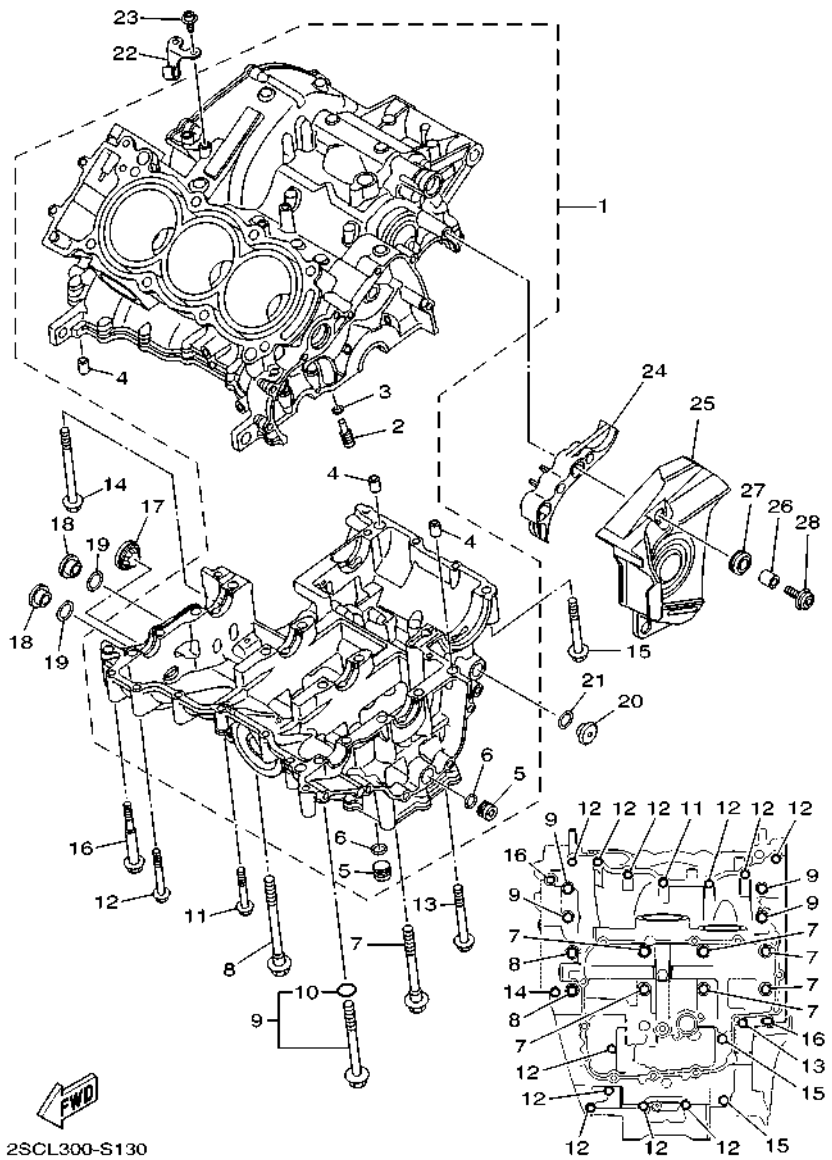

2SCL300-S130

FIG. 13 CRANKCASE

REF. NO.	PART NO.	DESCRIPTION	BOS2			REMARKS
1	BS2-15100-09	CRANKCASE ASSY	1			
2	5EB-15155-00	.NOZZLE 3	3			
3	93210-04092	.O-RING	3			
4	99530-10014	.PIN, DOWEL	3			
5	90338-16262	.PLUG	2			
6	93210-12790	.O-RING	2			
7	90119-09013	BOLT, WITH WASHER	6			
8	90119-09010	BOLT, WITH WASHER	2			
9	23P-15156-00	BOLT, CRANKCASE JOURNAL	4			
10	93210-07540	.O-RING	1			
11	95812-06040	BOLT, FLANGE	1			
12	95812-06050	BOLT, FLANGE	11			
13	95812-06065	BOLT, FLANGE	1			
14	90105-06202	BOLT, FLANGE	1			
15	95812-08060	BOLT, FLANGE	2			
16	90109-06100	BOLT	2			
17	2H7-15361-00	GAUGE, LEVEL	1			
18	36Y-15189-00	PLUG	2			
19	93210-16325	O-RING	2			
20	90340-14011	PLUG, STRAIGHT SCREW	1			
21	93210-14369	O-RING	1			
22	1RC-15441-00	HOLDER, CLUTCH CABLE	1			
23	90110-06108	BOLT, HEXAGON SOCKET HEAD	2			
24	1RC-15377-00	GUIDE, INLET	1			
25	BS2-15418-00	COVER, CHAIN CASE	1			
26	90387-06286	COLLAR	3			
27	90480-13018	GROMMET	3			

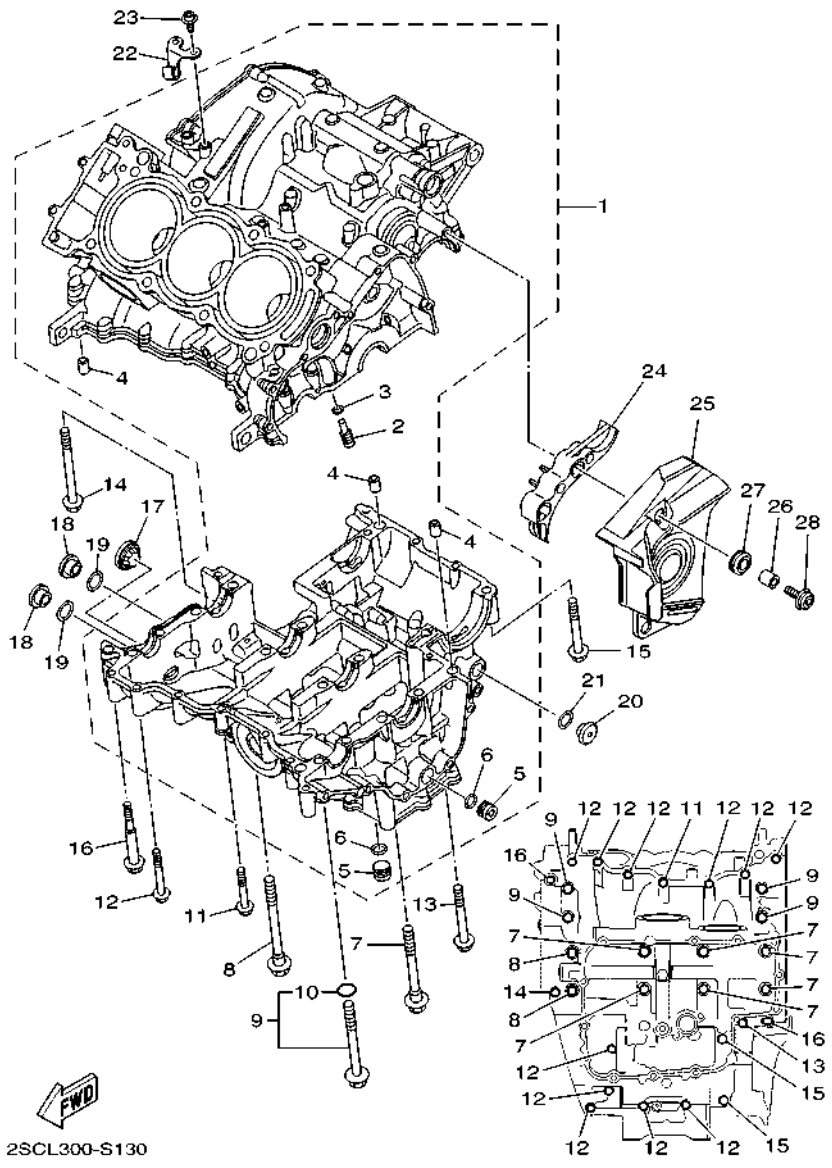
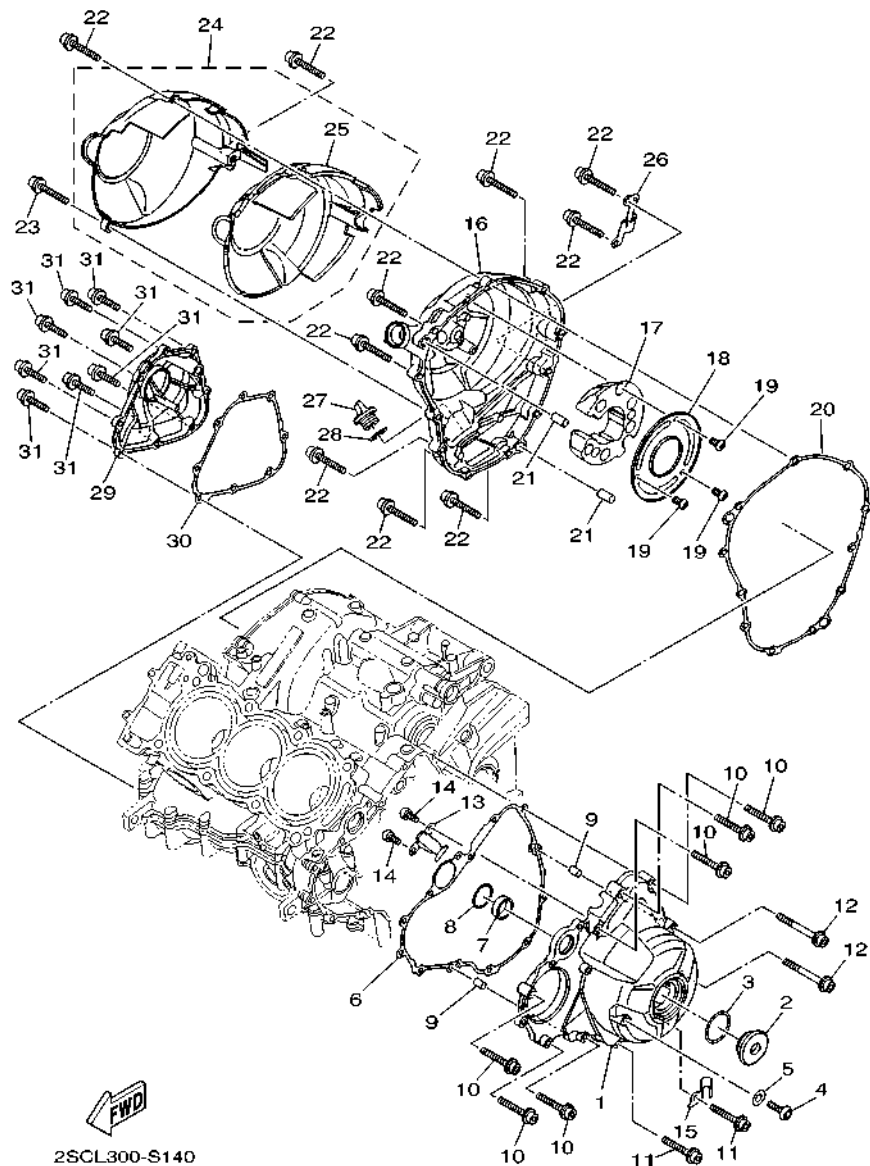

FIG. 13 CRANKCASE

REF. NO.	PART NO.	DESCRIPTION	BOS2				REMARKS
28	90111-06130	BOLT, HEX.SOCKET BUTTON	3				

FIG. 14 CRANKCASE COVER 1



2SCL300-S140

REF. NO.	PART NO.	DESCRIPTION	BOS2				REMARKS
1	1RC-15411-01	COVER, CRANKCASE 1	1				
2	90340-36005	PLUG, STRAIGHT SCREW	1				
3	93210-357A3	O-RING	1				
4	92017-08012	BOLT, BUTTON HEAD	1				
5	90430-08143	GASKET	1				
6	BD5-15451-00	GASKET, CRANKCASE COVER 1	1				
7	1RC-12564-00	PIPE, WATER	1				
8	93210-28543	O-RING	1				
9	99530-08012	PIN, DOWEL	2				
10	90110-06388	BOLT, HEXAGON SOCKET HEAD	6				
11	90110-06389	BOLT, HEXAGON SOCKET HEAD	2				
12	90110-06394	BOLT, HEXAGON SOCKET HEAD	2				
13	1RC-15484-00	CLAMP 2	1				
14	90110-06168	BOLT, HEXAGON SOCKET HEAD	2				
15	1RC-15199-00	BRACKET	1				
16	1RC-15421-11	COVER, CRANKCASE 2	1				
17	B90-15316-00	DAMPER 1	1				
18	B90-15492-00	COVER	1				
19	90149-06158	SCREW	3				
20	1RC-15461-00	GASKET, CRANKCASE COVER 2	1				
21	93610-20189	PIN, DOWEL	2				
22	90110-06388	BOLT, HEXAGON SOCKET HEAD	10				
23	90110-06321	BOLT, HEXAGON SOCKET HEAD	1				
24	BS2-15490-00	COVER ASSY	1				
25	B90-15326-00	.DAMPER 2	1				
26	1RC-15191-00	PLATE	1				
27	5GJ-15363-10	PLUG, OIL	1				

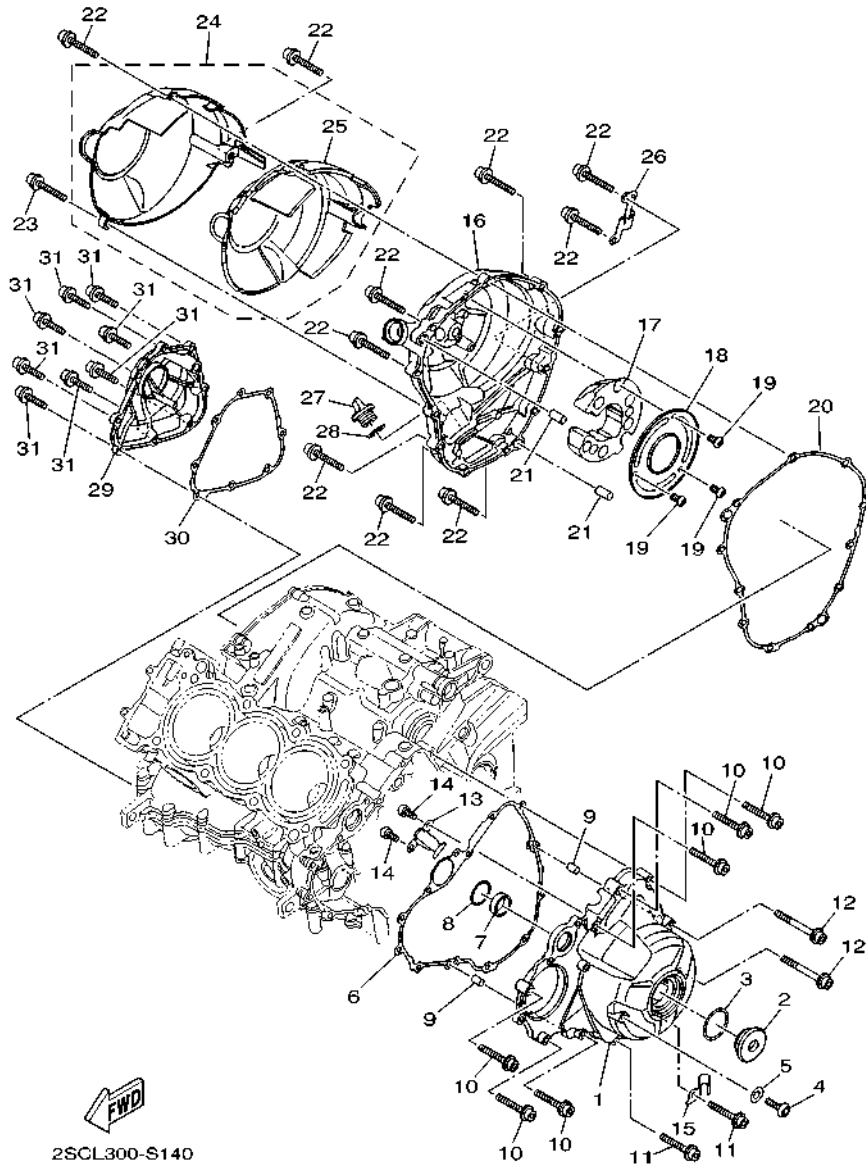
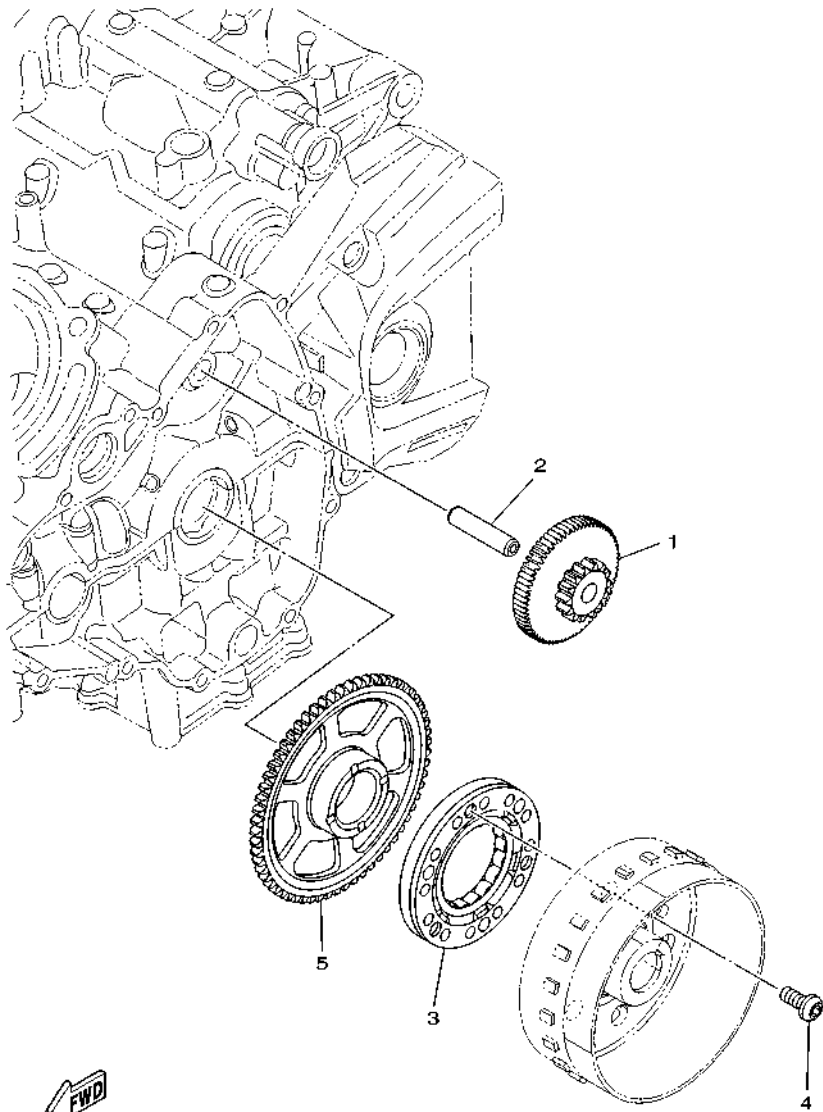

FIG. 14 CRANKCASE COVER 1

REF. NO.	PART NO.	DESCRIPTION	BOS2				REMARKS
28	93210-19123	O-RING	1				
29	1RC-15416-00	COVER, OIL PUMP	1				
30	1RC-15456-00	GASKET, OIL PUMP COVER 1	1				
31	90110-06396	BOLT, HEXAGON SOCKET HEAD	8				



1RC1300-N150

FIG. 15 STARTER

REF. NO.	PART NO.	DESCRIPTION	BOS2				REMARKS
1	1RC-15512-00	GEAR, IDLER 1	1				
2	5EB-15521-00	SHAFT 1	1				
3	1RC-15590-00	STARTER ONE-WAY ASSY	1				
4	90149-08030	SCREW	3				
5	1RC-15515-00	GEAR 3	1				

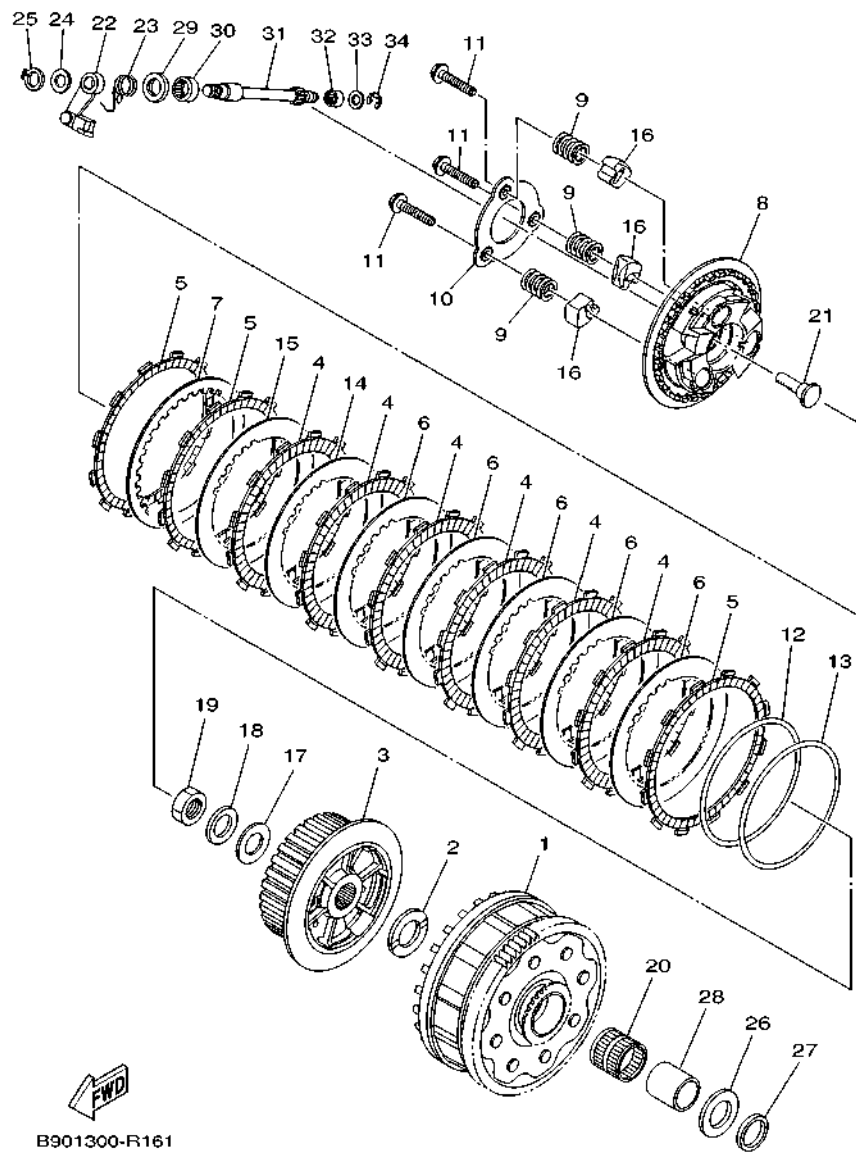

B901300-R161

FIG. 16 CLUTCH

REF. NO.	PART NO.	DESCRIPTION	BOS2	REMARKS
1	1RC-16150-00	PRIMARY DRIVEN GEAR COMP.	1	
2	5VY-16154-00	PLATE, THRUST 1	1	
3	B90-16371-10	BOSS, CLUTCH	1	
4	5TA-16321-00	PLATE, FRICTION	6	
5	B90-16331-00	PLATE, FRICTION 2	3	
6	5VY-16325-00	PLATE, CLUTCH 2	5	(T2.0)
7	1TD-16324-00	PLATE, CLUTCH 1	1	
8	B90-16350-10	PRESSURE PLATE ASSY	1	
9	B90-16173-00	SPRING, COMPRESSION	3	
10	B90-16352-00	PLATE, PRESSURE 2	1	
11	2CR-16337-00	SCREW, SPRING	3	
12	1TD-16383-00	SPRING, CUSHION	1	
13	1TD-16384-00	PLATE, SEAT	1	
14	4B1-16325-00	PLATE, CLUTCH 2	1	UR (T2.3)
	BR9-16324-00	PLATE, CLUTCH 1	1	UR (T1.6)
	5VY-16325-00	PLATE, CLUTCH 2	1	UR (T2.0)
15	4B1-16325-00	PLATE, CLUTCH 2	1	UR (T2.3)
	BR9-16324-00	PLATE, CLUTCH 1	1	UR (T1.6)
	5VY-16325-00	PLATE, CLUTCH 2	1	UR (T2.0)
16	1TD-16178-00	ABSORBER 3	3	
17	90201-20030	WASHER, PLATE	1	
18	90208-20001	WASHER, CONICAL SPRING	1	
19	90179-20011	NUT	1	
20	93310-33277	BEARING	1	
21	4XV-16356-01	ROD, PUSH 1	1	
22	1RC-16340-00	PUSH LEVER ASSY	1	
23	90508-18051	SPRING, TORSION	1	

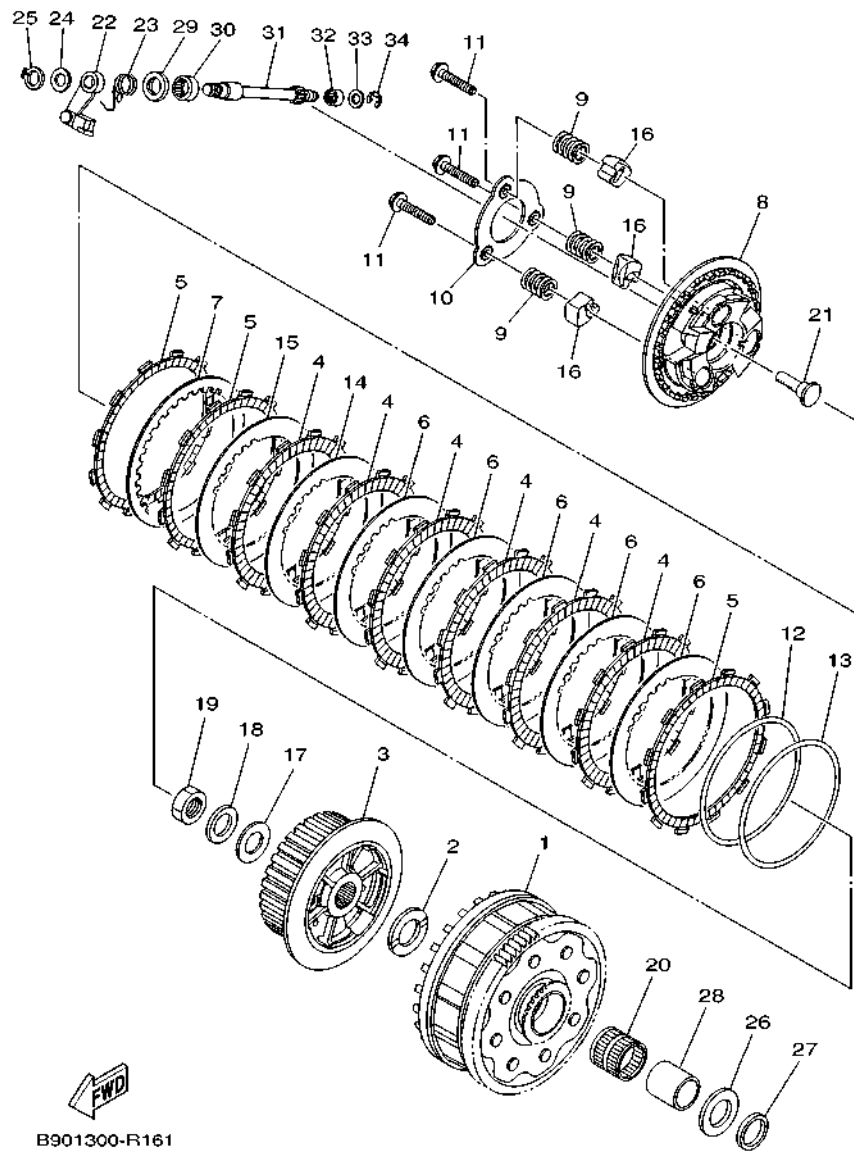

B901300-R161

FIG. 16 CLUTCH

REF. NO.	PART NO.	DESCRIPTION	BOS2				REMARKS
24	90201-10029	WASHER, PLATE	1				
25	99009-10400	CIRCLIP	1				
26	5VY-16164-00	PLATE, THRUST 2	1				
27	2C0-16164-00	PLATE, THRUST 2	1				
28	1RC-16181-00	SPACER 1	1				
29	93102-15212	OIL SEAL	1				
30	93315-21570	BEARING	1				
31	5VY-16382-10	AXLE, PUSH LEVER	1				
32	93317-11096	BEARING	1				
33	92907-08600	WASHER, PLATE	1				
34	99001-07600	CIRCLIP	1				

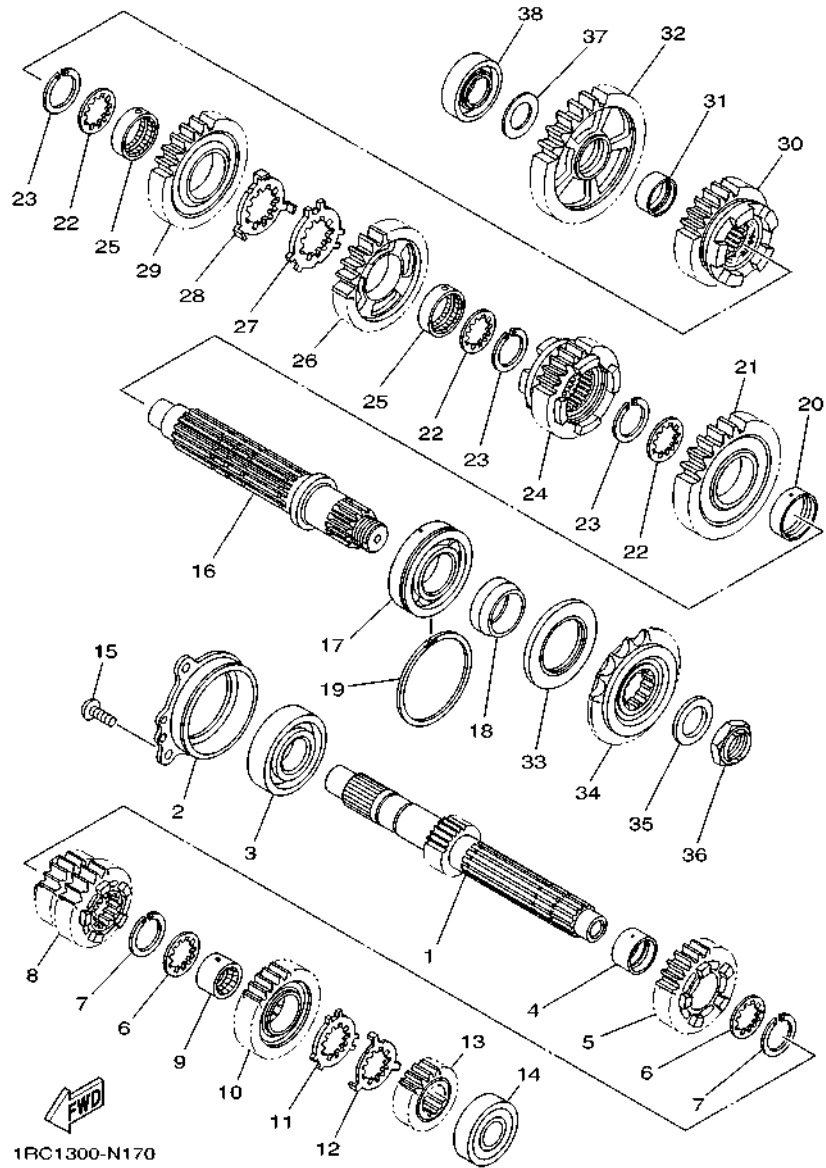

FIG. 17 TRANSMISSION

REF. NO.	PART NO.	DESCRIPTION	BOS2				REMARKS
1	1RC-17411-00	AXLE, MAIN (15T)	1				
2	1RC-15163-00	HOUSING, BEARING 1	1				
3	93306-30534	BEARING	1				
4	90387-25030	COLLAR	1				
5	1RC-17151-00	GEAR, 5TH PINION (21T)	1				
6	90209-21332	WASHER	2				
7	93440-25186	CIRCLIP	2				
8	1RC-17131-00	GEAR, 3RD PINION (21T/21T)	1				
9	90387-21003	COLLAR	1				
10	1RC-17161-00	GEAR, 6TH PINION (27T)	1				
11	90209-22352	WASHER	1				
12	90209-21351	WASHER	1				
13	1RC-17121-00	GEAR, 2ND PINION (19T)	1				
14	93306-20464	BEARING	1				
15	90149-06082	SCREW	3				
16	1RC-17421-00	AXLE, DRIVE	1				
17	93306-20663	BEARING	1				
18	90387-30012	COLLAR	1				
19	93440-64199	CIRCLIP	1				
20	90387-31003	COLLAR	1				
21	2PP-17221-00	GEAR, 2ND WHEEL (38T)	1				
22	90209-28008	WASHER	3				
23	93440-31187	CIRCLIP	3				
24	2PP-17261-00	GEAR, 6TH WHEEL (28T)	1				
25	90387-28004	COLLAR	2				
26	1RC-17241-00	GEAR, 4TH WHEEL (29T)	1				
27	90214-29002	WASHER, CLAW	1				

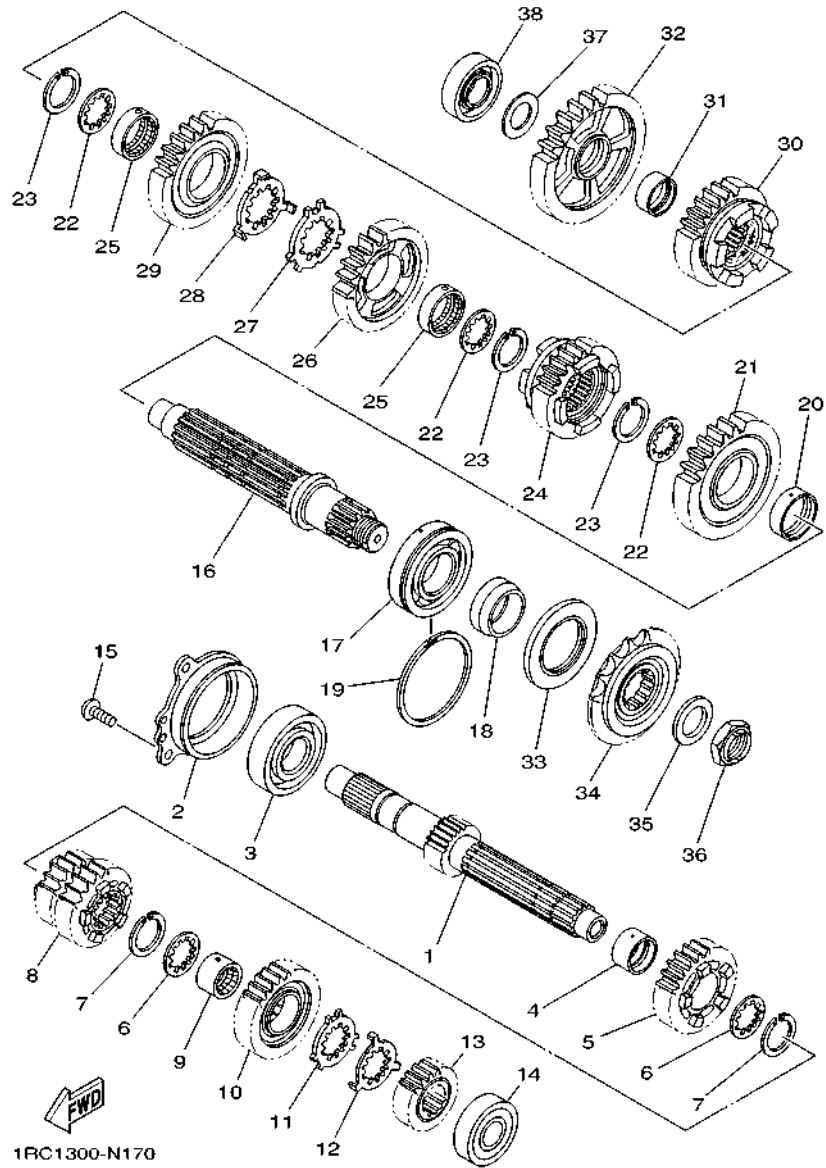
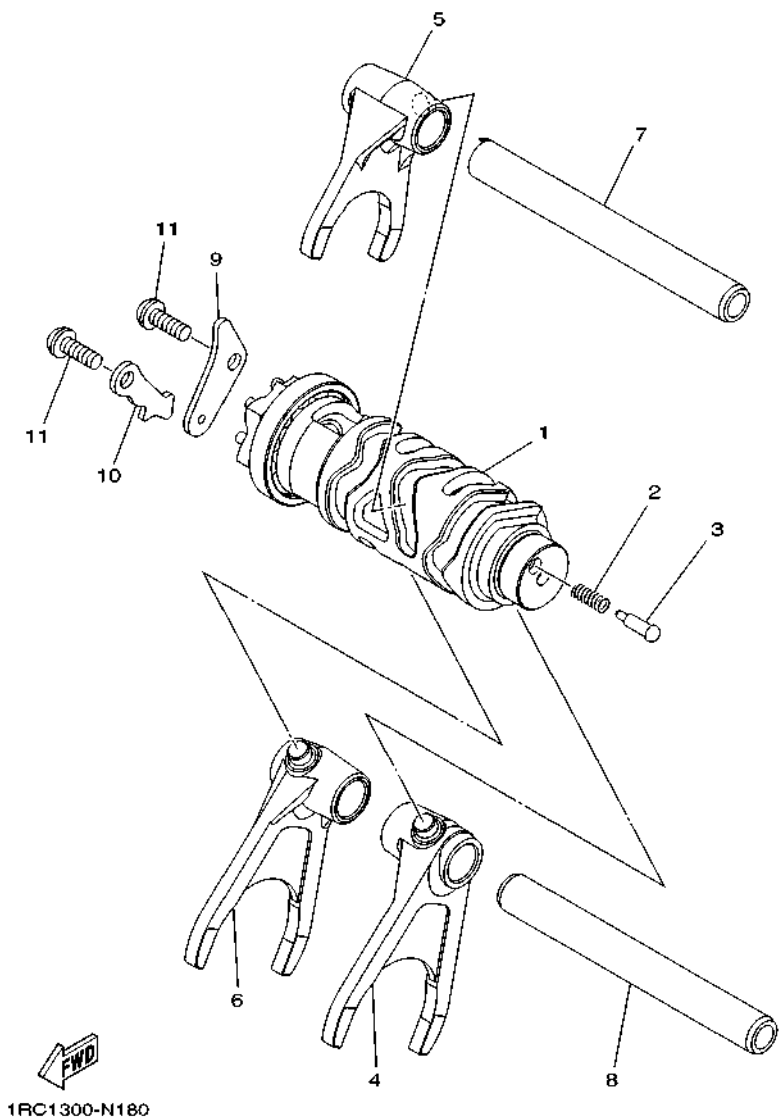

FIG. 17 TRANSMISSION

REF. NO.	PART NO.	DESCRIPTION	BOS2				REMARKS
28	90214-28002	WASHER, CLAW	1				
29	1RC-17231-00	GEAR, 3RD WHEEL (34T)	1				
30	1RC-17251-10	GEAR, 5TH WHEEL (25T)	1				
31	90387-25008	COLLAR	1				
32	1RC-17211-00	GEAR, 1ST WHEEL (40T)	1				
33	93102-40030	OIL SEAL	1				
34	5PS-17460-00	SPROCKET, DRIVE (16T)	1				
35	90208-22002	WASHER, CONICAL SPRING	1				
36	90179-22018	NUT	1				
37	90201-20008	WASHER, PLATE	1				
38	93306-20464	BEARING	1				

FIG. 18 SHIFT CAM & FORK



REF. NO.	PART NO.	DESCRIPTION	BOS2				REMARKS
1	1RC-18540-00	SHIFT CAM ASSY	1				
2	90501-06022	SPRING, COMPRESSION	1				
3	3D7-18542-00	POINT, NEUTRAL	1				
4	1RC-18511-00	FORK, SHIFT 1	1				
5	1RC-18512-00	FORK, SHIFT 2	1				
6	1RC-18513-00	FORK, SHIFT 3	1				
7	1RC-18531-00	BAR, SHIFT FORK GUIDE 1	1				
8	20S-18535-00	BAR, SHIFT FORK GUIDE 2	1				
9	2C0-18536-00	STOPPER, SHIFT BAR	1				
10	1RC-18562-00	PLATE, STOPPER 2	1				
11	90149-06158	SCREW	2				

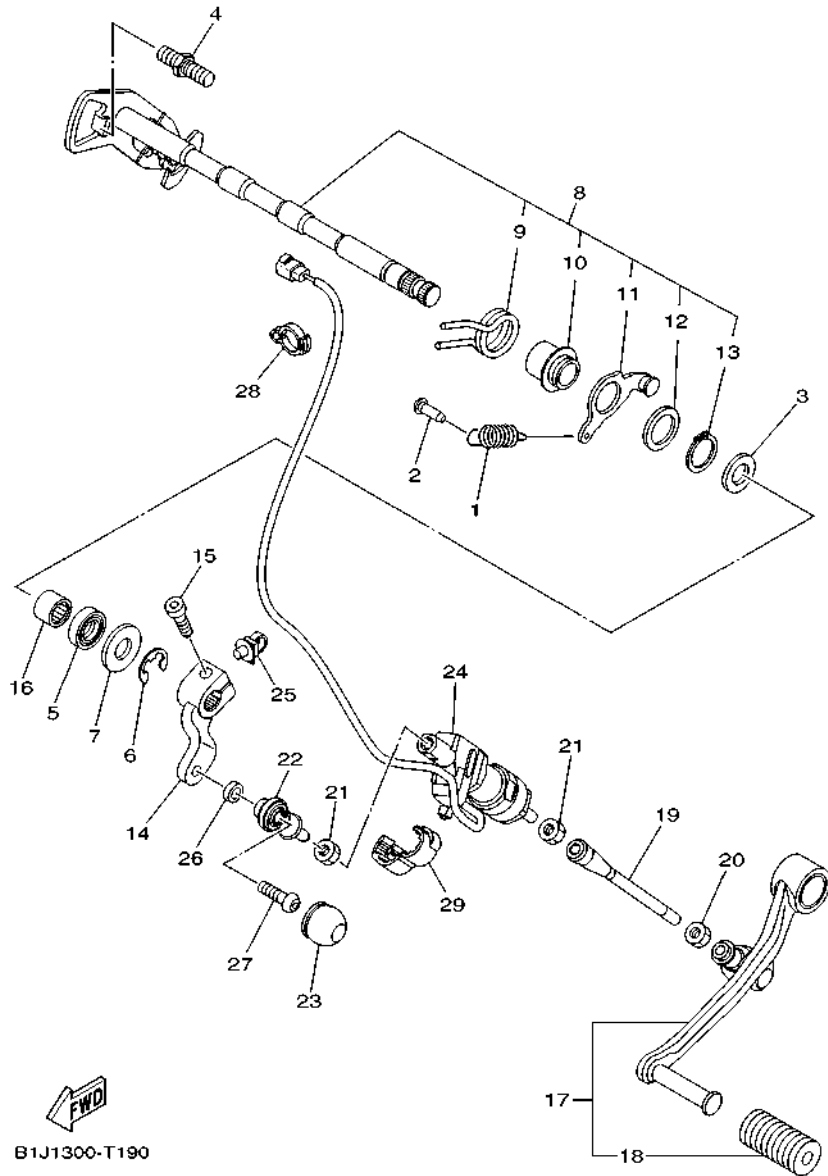

FIG. 19 SHIFT SHAFT

REF. NO.	PART NO.	DESCRIPTION	BOS2				REMARKS
1	90506-18021	SPRING, TENSION	1				
2	132-16346-00	HOOK, SPRING	1				
3	90201-127E1	WASHER, PLATE	1				
4	1D7-18127-00	STOPPER, SCREW	1				
5	93102-12106	OIL SEAL (SD 12-22-5 HS)	1				
6	99002-10600	CIRCLIP	1				
7	90201-12575	WASHER, PLATE	1				
8	1RC-18101-01	SHIFT SHAFT ASSY	1				
9	90508-32141	.SPRING, TORSION	1				
10	2C0-18175-00	.SPACER	1				
11	1RC-18140-00	.STOPPER LEVER ASSY	1				
12	90201-177G4	.WASHER, PLATE	1				
13	99009-17400	.CIRCLIP	1				
14	1RC-18112-00	ARM, SHIFT	1				
15	91312-06020	BOLT, HEXAGON SOCKET HEAD	1				
16	93317-11295	BEARING	1				
17	1RC-18110-00	SHIFT PEDAL ASSY	1				
18	5EB-18113-00	.COVER, SHIFT PEDAL	1				
19	BS2-18115-00	ROD, SHIFT	1				
20	90170-06228	NUT (COUNTER CLOCKWISE)	1				
21	95304-06700	NUT	2				
22	5LV-18116-00	JOINT, ROD 1	1				
23	4XV-18154-00	COVER, DUST	1				
24	BS2-82470-00	SHIFT SWITCH ASSY	1				
25	90464-30011	CLAMP	1				
26	90387-06322	COLLAR	1				
27	92012-06020	BOLT, BUTTON HEAD	1				

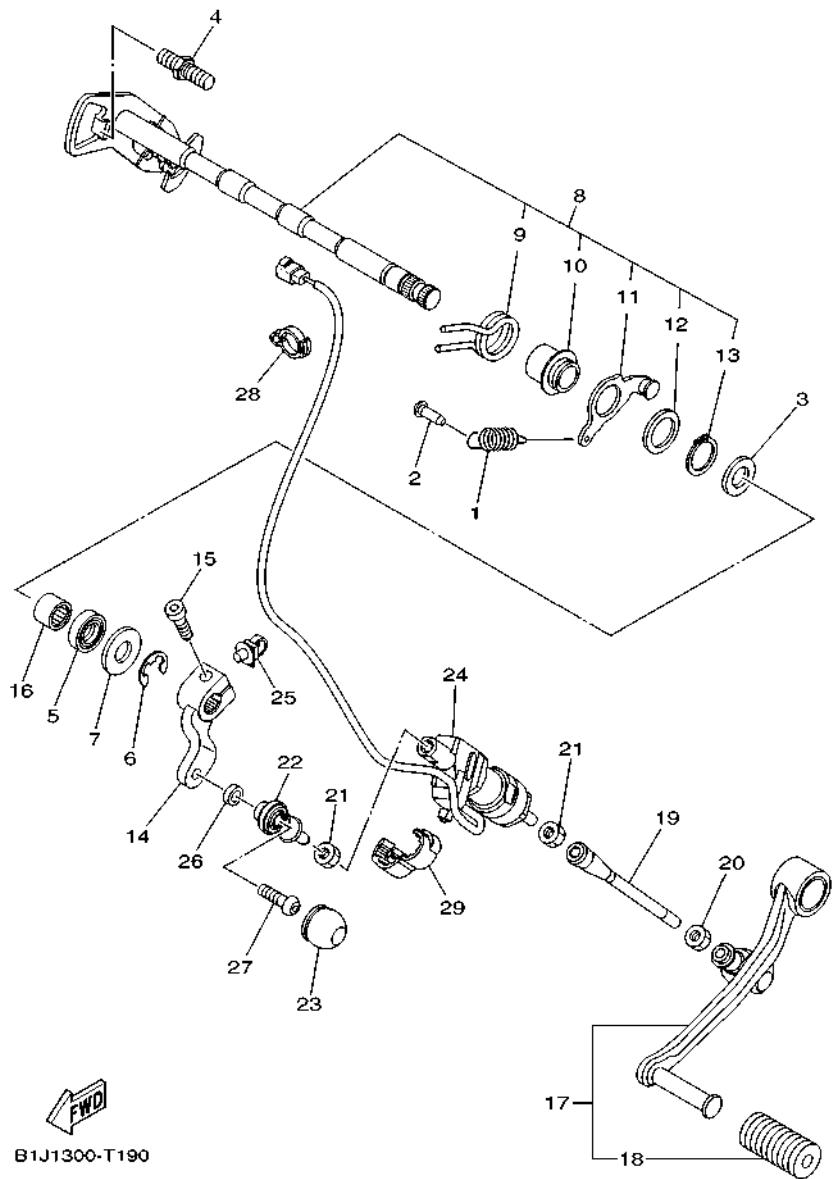
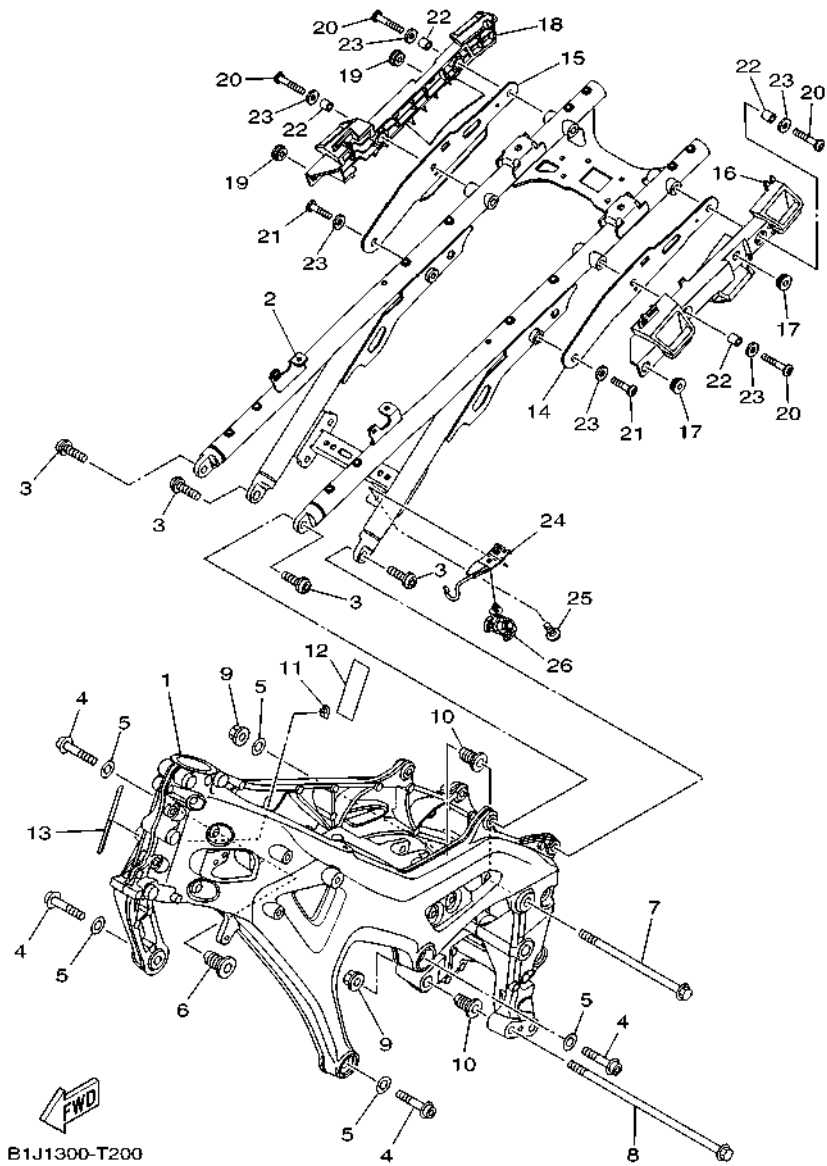

FIG. 19 SHIFT SHAFT

REF. NO.	PART NO.	DESCRIPTION	BOS2				REMARKS
28	90464-14010	CLAMP	1				
29	90464-13227	CLAMP	1				



B1J1300-T200

FIG. 20 FRAME

REF. NO.	PART NO.	DESCRIPTION	BOS2			REMARKS
1	B1J-21110-00	FRAME COMP.	1			
2	B5C-21190-00	REAR FRAME COMP.	1			
3	90149-10060	SCREW	4			
4	90110-10043	BOLT, HEXAGON SOCKET HEAD	4			
5	90201-10075	WASHER, PLATE	5			
6	1RC-21495-00	BOLT, ENGINE ADJUSTING	1			
7	90105-10391	BOLT, FLANGE	1			
8	90105-10437	BOLT, FLANGE	1			
9	90179-10024	NUT	2			
10	4C8-21495-00	BOLT, ENGINE ADJUSTING	2			
11	5VX-21289-00	PLUG, BLIND	1			
12	34D-82176-00	DAMPER	1			
13	1RC-2117G-00	PROTECTOR	1			
14	B5C-21214-00	REINF., FRAME RR.	1			
15	B5C-21224-00	REINF., FRAME RR.	1			
16	B5C-2164H-00	STAY 3	1			
17	90480-13398	GROMMET	2			
18	B5C-2164J-00	STAY 4	1			
19	90480-13398	GROMMET	2			
20	90149-08220	SCREW	4			
21	90110-08220	BOLT, HEXAGON SOCKET HEAD	2			
22	90387-08077	COLLAR	4			
23	90201-087P8	WASHER, PLATE	6			
24	B1J-22465-00	HOLDER	1			
25	90111-06103	BOLT, HEX. SOCKET BUTTON	1			
26	90464-13249	CLAMP	1			

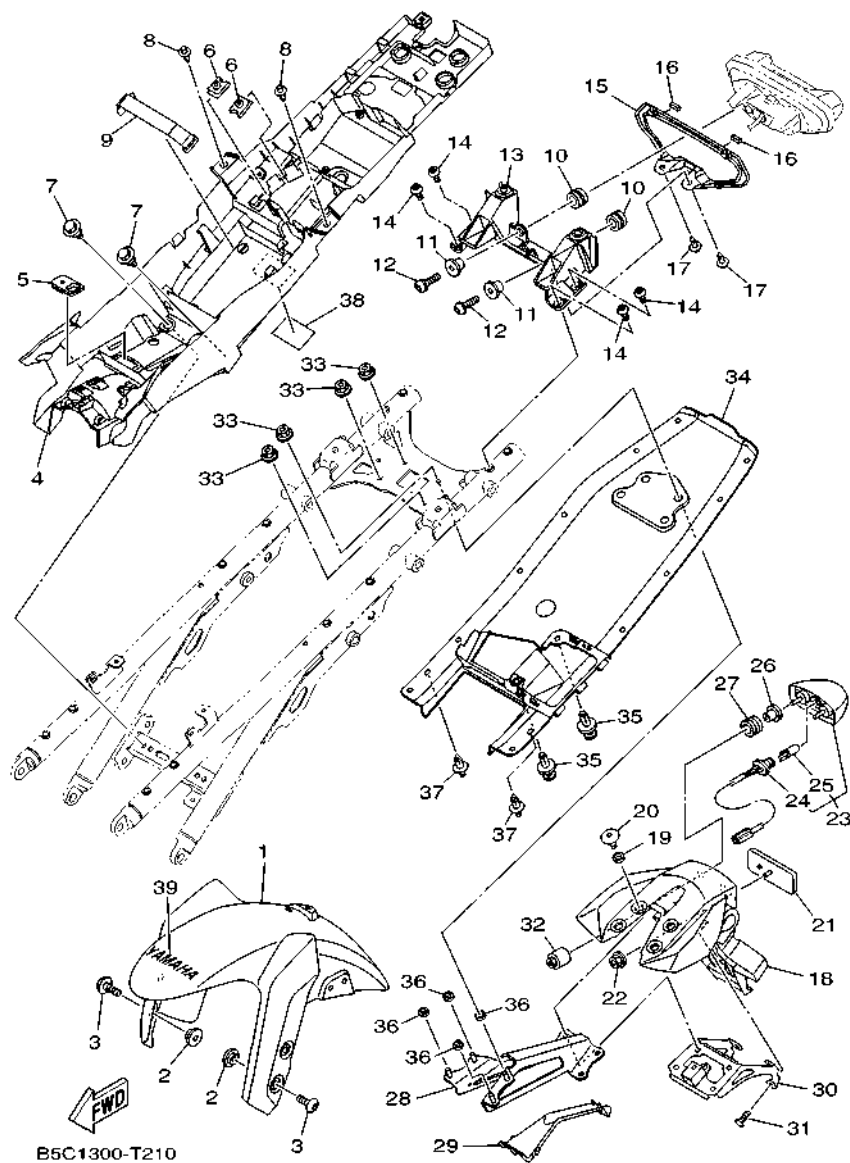

FIG. 21 FENDER

REF. NO.	PART NO.	DESCRIPTION	BOS2	REMARKS
1	1RC-21511-00-P0	FENDER, FRONT	1	UR MBL2 FOR BNS4
	1RC-21511-00-PE	FENDER, FRONT	1	UR FOR MDPBM1
2	90387-06153	COLLAR	4	
3	90110-06200	BOLT, HEXAGON SOCKET HEAD	4	
4	B5C-8212B-00	BOX, BATTERY 1	1	
5	2DR-26199-00	PLUG, BLIND	1	
6	90183-06069	NUT, SPRING	2	
7	90109-06202	BOLT	2	
8	90269-07007	RIVET	2	
9	1RC-82137-00	BAND, BATTERY	1	
10	90480-12015	GROMMET	2	
11	90387-06288	COLLAR	2	
12	92012-06020	BOLT, BUTTON HEAD	2	
13	2PP-2117E-00	BRACKET, TAILLIGHT	1	
14	90111-06029	BOLT, HEX. SOCKET BUTTON	4	
15	2PP-2163A-00	COVER, REAR FENDER 1	1	
16	1RC-21747-00	DAMPER	2	
17	90269-07007	RIVET	2	
18	1RC-21629-01	GUARD, MUD	1	
19	90387-06372	COLLAR	4	
20	90111-06089	BOLT, HEX. SOCKET BUTTON	4	
21	3Y6-85130-02	REAR REFLECTOR ASSY	1	
22	95602-05200	NUT, SELF-LOCKING	1	
23	1WS-84740-00	LICENCE LIGHT ASSY	1	
24	1WS-84547-00	.CORD, LICENCE LIGHT	1	
25	1TP-84347-00	.BULB (12V-5W)	1	
26	90387-05042	COLLAR	2	

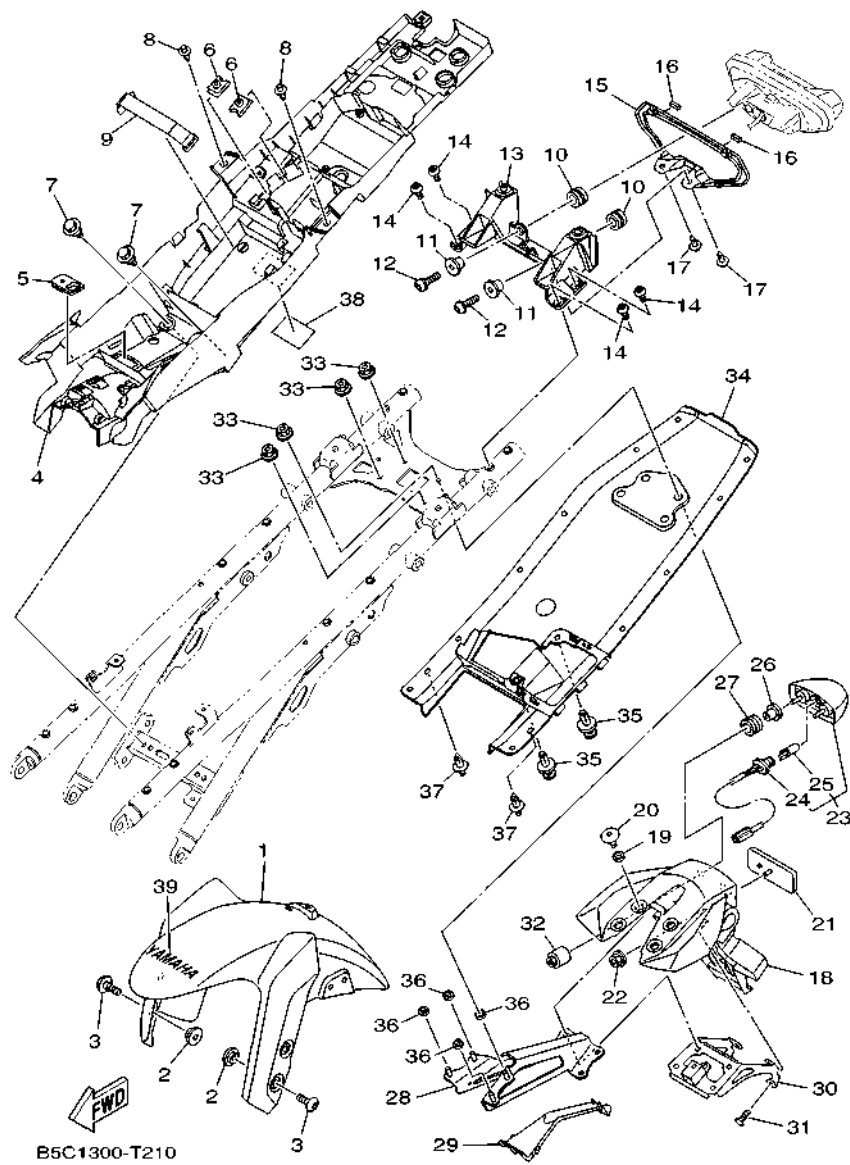
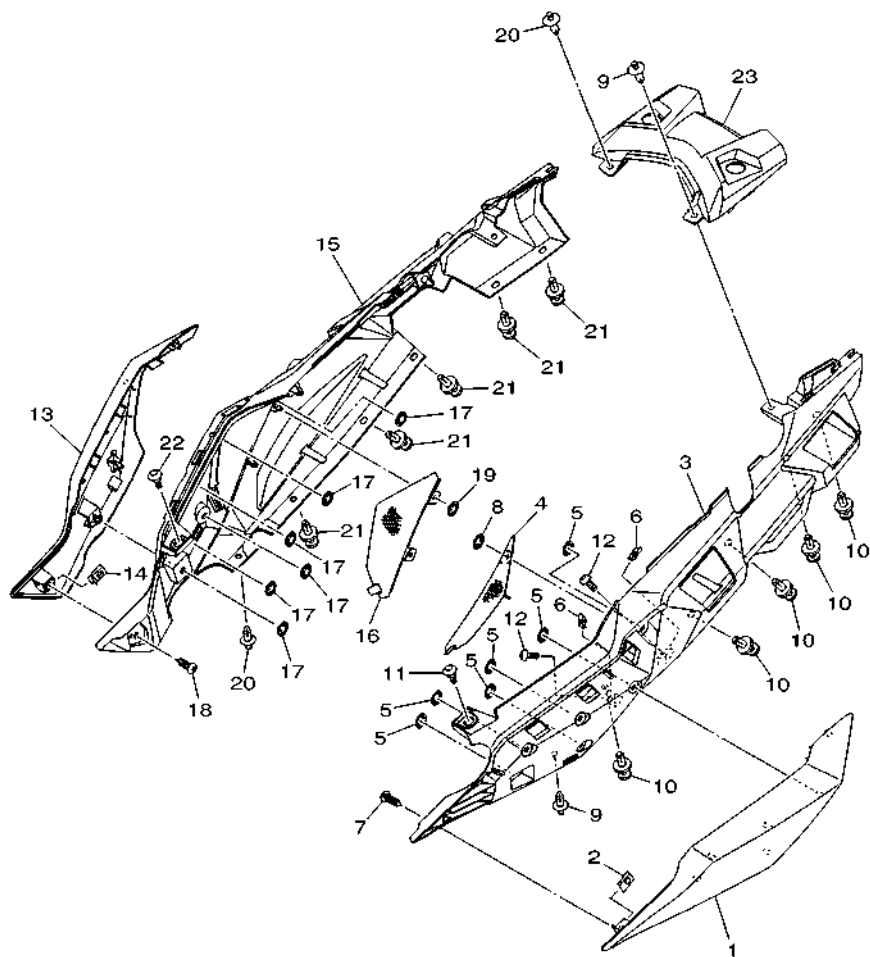

FIG. 21 FENDER

REF. NO.	PART NO.	DESCRIPTION	BOS2			REMARKS
27	90480-11009	GROMMET	2			
28	2PP-2164F-00	STAY 1	1			
29	2PP-2163E-00	COVER, REAR FENDER 2	1			
30	2PP-21682-00	STAY, PLATE	1			
31	90160-05012	SCREW, ROUND TAPPING	4			
32	1RC-2622H-00	WEIGHT	2			
33	95602-06200	NUT, SELF-LOCKING	4			
34	2PP-21651-00	COVER, REAR FENDER	1			
35	90269-07076	RIVET	2			
36	90387-06302	COLLAR	4			
37	90269-07007	RIVET	2			
38	B5C-21668-00	LABEL, TIRE	1			
39	99247-00080	EMBLEM, YAMAHA	1			UR FOR BNS4
	99244-00080	EMBLEM, YAMAHA	1			UR FOR MDPBM1

FIG. 22 SIDE COVER



B5C1300-T220

REF. NO.	PART NO.	DESCRIPTION	BOS2	REMARKS
1	B5C-21711-00-P1	COVER, SIDE 1	1	UR FOR BNS4
	B5C-21711-00-P3	COVER, SIDE 1	1	UR FOR MDPBM1
2	90183-05042	NUT, SPRING	1	
3	B5C-21731-00	COVER, SIDE 3	1	
4	B5C-2171Y-00	GRILLE, SIDE COVER 1	1	
5	90183-05M02	NUT, SPRING	6	
6	90183-05076	NUT, SPRING	2	
7	97707-50012	SCREW, TRUSS HEAD TAPPING	1	
8	90183-05M02	NUT, SPRING	1	
9	90269-07007	RIVET	2	
10	90269-07076	RIVET	5	
11	90111-05045	BOLT,HEX. SOCKET BUTTON	1	
12	92012-05010	BOLT, BUTTON HEAD	2	
13	B5C-21721-00-P1	COVER, SIDE 2	1	UR FOR BNS4
	B5C-21721-00-P3	COVER, SIDE 2	1	UR FOR MDPBM1
14	90183-05042	NUT, SPRING	1	
15	B5C-21741-00	COVER, SIDE 4	1	
16	B5C-2172Y-00	GRILLE, SIDE COVER 2	1	
17	90183-05M02	NUT, SPRING	6	
18	97707-50012	SCREW, TRUSS HEAD TAPPING	1	
19	90183-05M02	NUT, SPRING	1	
20	90269-07007	RIVET	2	
21	90269-07076	RIVET	5	
22	90111-05045	BOLT,HEX. SOCKET BUTTON	1	
23	B5C-2171A-00	COVER, TOP	1	

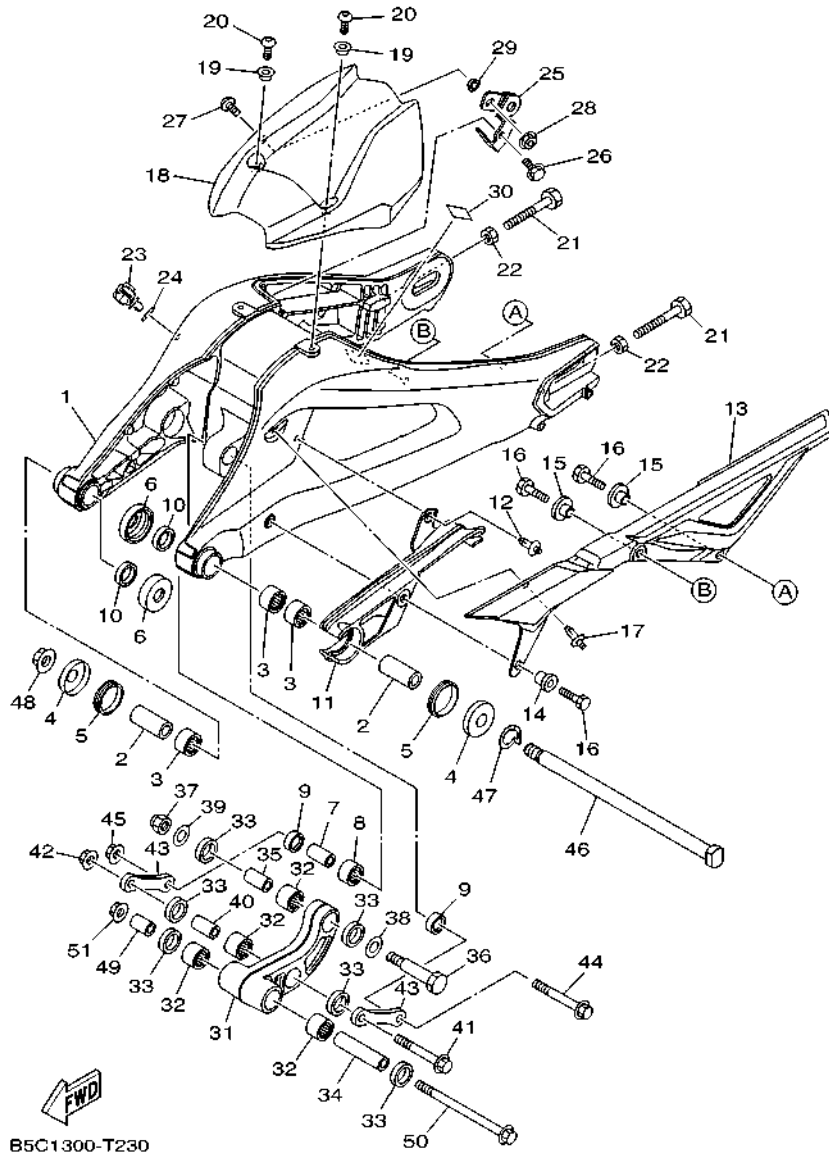

FIG. 23 REAR ARM

REF. NO.	PART NO.	DESCRIPTION	BOS2				REMARKS
1	B5C-22110-00	REAR ARM COMP.	1				
2	90380-16134	BUSH, SOLID	2				
3	93317-22262	BEARING	3				
4	30X-2219X-00	COVER	2				
5	93108-35004	OIL SEAL (35-41-8)	2				
6	20S-22128-00	COVER, THRUST 1	2				
7	90387-102R4	COLLAR	1				
8	93315-31758	BEARING	1				
9	93109-17071	OIL SEAL	2				
10	93106-22002	OIL SEAL	2				
11	B5C-22151-00	SEAL, GUARD	1				
12	90269-07007	RIVET	1				
13	B5C-22311-00	CASE, CHAIN	1				
14	90387-062X0	COLLAR	1				
15	90387-06066	COLLAR	2				
16	97002-06016	BOLT, HEXAGON	3				
17	90269-07007	RIVET	1				
18	B5C-21650-00	REAR FENDER COMP.	1				
19	90387-06075	COLLAR	2				
20	92014-06016	BOLT, BUTTON HEAD	2				
21	90101-08013	BOLT	2				
22	95302-08600	NUT, HEXAGON	2				
23	90464-18002	CLAMP	1				
24	90202-07164	WASHER, PLATE	1				
25	B5C-22131-00	STAY, CHAIH CASE 1	1				
26	90105-06126	BOLT, FLANGE	1				
27	90111-06029	BOLT,HEX. SOCKET BUTTON	1				

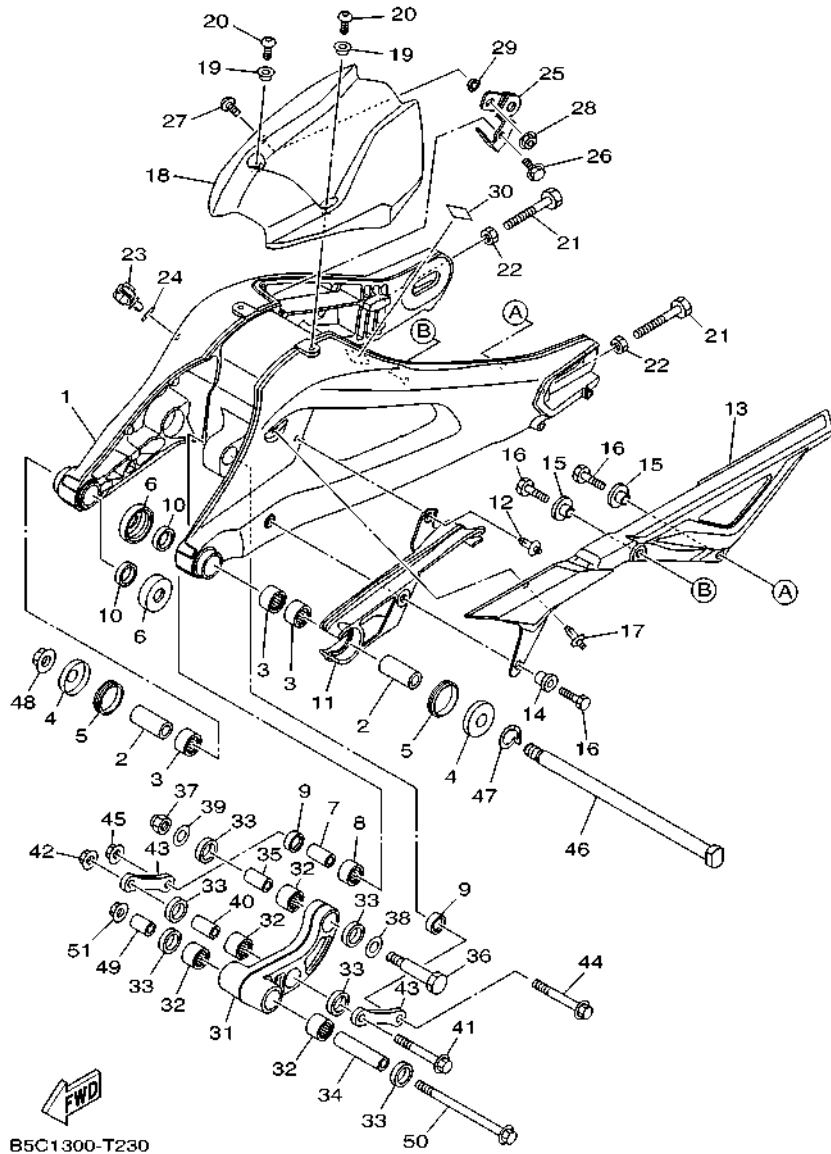
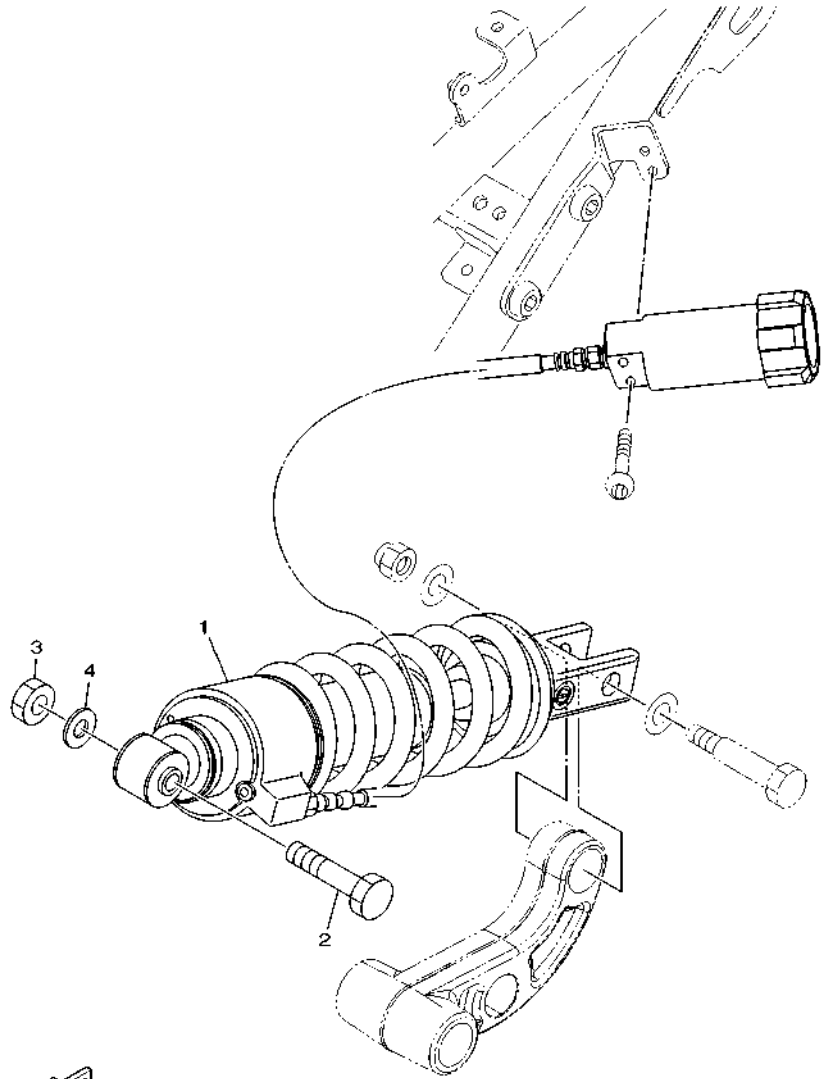

FIG. 23 REAR ARM

REF. NO.	PART NO.	DESCRIPTION	BOS2				REMARKS
28	95607-06200	NUT, SELF U-FLANGE	1				
29	90387-06210	COLLAR	1				
30	2C0-21566-00	TAPE, 1	1				
31	1RC-2217A-00	ARM, RELAY	1				
32	93315-31758	BEARING	4				
33	93109-17071	OIL SEAL	6				
34	3GB-23448-00	SPACER	1				
35	90387-127W0	COLLAR	1				
36	90109-10019	BOLT	1				
37	95612-10100	NUT, U	1				
38	90201-13015	WASHER, PLATE	1				
39	90201-10035	WASHER, PLATE	1				
40	90387-102R4	COLLAR	1				
41	90105-10210	BOLT, FLANGE	1				
42	95602-10200	NUT, S/L FLANGE	1				
43	1RC-2217M-00	ARM 1	2				
44	90105-10210	BOLT, FLANGE	1				
45	95602-10200	NUT, S/L FLANGE	1				
46	46X-22141-00	SHAFT, PIVOT	1				
47	1RC-22159-00	WASHER, SPRING LOWER	1				
48	95602-14200	NUT, SELF-LOCKING	1				
49	90387-10106	COLLAR	1				
50	90105-10174	BOLT, FLANGE	1				
51	95602-10200	NUT, S/L FLANGE	1				



B1J1300-T240

FIG. 24 REAR SUSPENSION

REF. NO.	PART NO.	DESCRIPTION	BOS2	REMARKS
1	B1J-22210-00	SHOCK ABSORBER ASSY, REAR	1	
2	90101-10042	BOLT	1	
3	95602-10100	NUT, U	1	
4	90201-101J1	WASHER, PLATE	1	
<hr/>				
<hr/>				
<hr/>				
<hr/>				
<hr/>				
<hr/>				
<hr/>				
<hr/>				
<hr/>				
<hr/>				

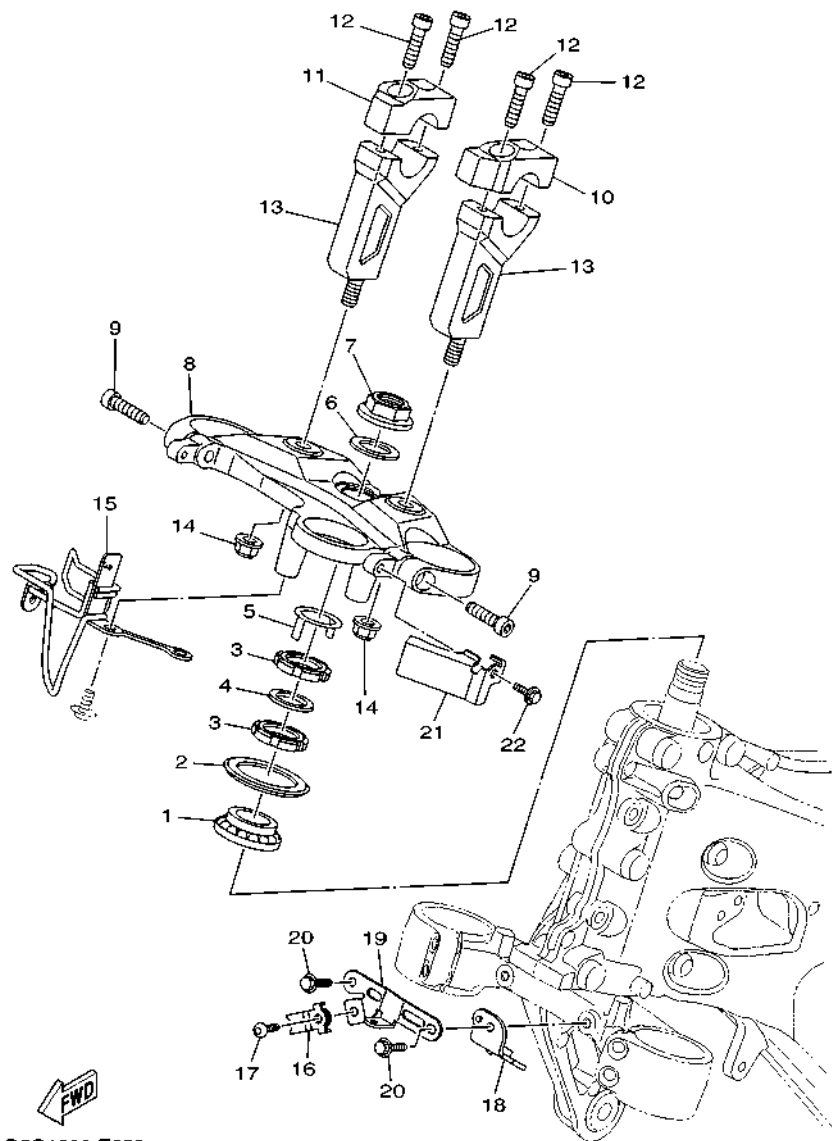

B5C1300-T250

FIG. 25 STEERING

REF. NO.	PART NO.	DESCRIPTION	BOS2				REMARKS
1	93399-99931	BEARING	1				
2	5VX-23415-00	COVER, BALL RACE 1	1				
3	90179-25004	NUT	2				
4	90202-26142	WASHER, PLATE	1				
5	26H-23418-01	WASHER, SPECIAL	1				
6	90201-22018	WASHER, PLATE	1				
7	1RC-23393-00	NUT, SPECIAL	1				
8	1RC-23435-40	CROWN, HANDLE	1				
9	91314-08030	BOLT, HEXAGON SOCKET HEAD	2				
10	2PP-23441-10	HOLDER, HANDLE UPPER	1				
11	2PP-2344A-10	HOLDER, HANDLE UPPER 1	1				
12	91314-08030	BOLT, HEXAGON SOCKET HEAD	4				
13	2PP-24847-11	HOLDER 1	2				
14	95602-10200	NUT, S/L FLANGE	2				
15	B5C-23389-00	GUIDE, CABLE	1				
16	90461-10008	CLAMP	1				
17	92017-06012	BOLT, BUTTON HEAD	1				
18	1RC-23377-00	BRACKET, HORN	1				
19	2PP-2334G-00	BRACKET 1	1				
20	95807-06016	BOLT, FLANGE	2				
21	B5C-23317-00	HOLDER, CABLE	1				
22	95027-06012	BOLT, FLANGE	1				

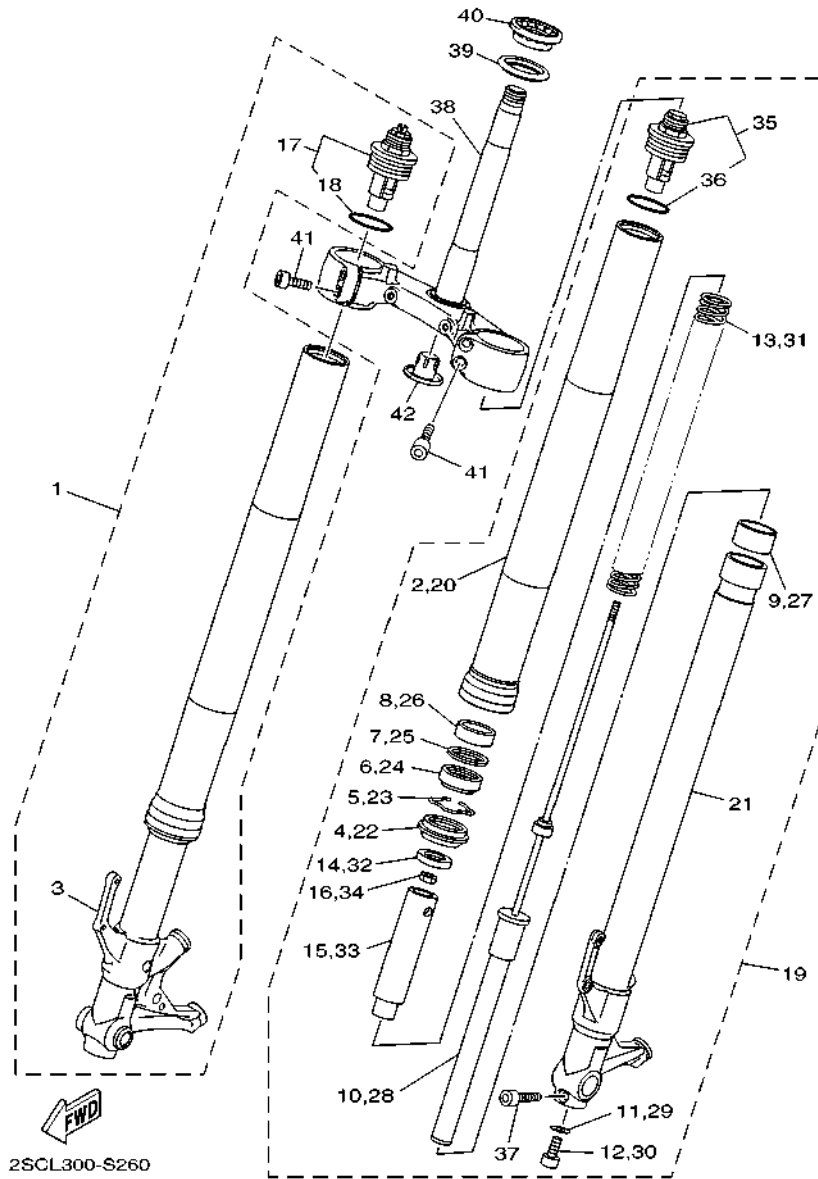

2SCL300-S260

FIG. 26 FRONT FORK

REF. NO.	PART NO.	DESCRIPTION	BOS2				REMARKS
1	B1J-23103-00	FRONT FORK ASSY (R.H)	1				
2	1RC-23126-11	.TUBE, OUTER (L.H)	1				
3	BS2-23120-00	.INNER TUBE COMP.2	1				
4	4EB-23144-00	.SEAL, DUST	1				
5	26H-23156-00	.RING, SNAP	1				
6	4EB-23145-01	.OIL SEAL	1				
7	36Y-23146-10	.WASHER, OIL SEAL	1				
8	1RC-23125-00	.METAL, SLIDE 1	1				
9	4FM-23171-40	.METAL, SLIDE	1				
10	B1J-23170-10	.CYLINDER COMP., FRONT FORK	1				
11	509-23158-L0	.GASKET	1				(KYB)
12	278-23181-50	.BOLT, HEXAGON SOCKET HEAD	1				
13	2PP-23141-00	.SPRING, FRONT FORK	1				
14	5VY-12277-00	.WASHER	1				
15	1RC-23118-00	.SPACER	1				
16	3LC-23357-00	.NUT	1				
17	BS2-23111-10	.BOLT, CAP	1				
18	3XJ-23147-L0	.O-RING	1				
19	B1J-23102-00	FRONT FORK ASSY (L.H)	1				
20	1RC-23126-11	.TUBE, OUTER (L.H)	1				
21	BS2-23110-00	.INNER TUBE COMP.1	1				
22	4EB-23144-00	.SEAL, DUST	1				
23	26H-23156-00	.RING, SNAP	1				
24	4EB-23145-01	.OIL SEAL	1				
25	36Y-23146-10	.WASHER, OIL SEAL	1				
26	1RC-23125-00	.METAL, SLIDE 1	1				
27	4FM-23171-40	.METAL, SLIDE	1				

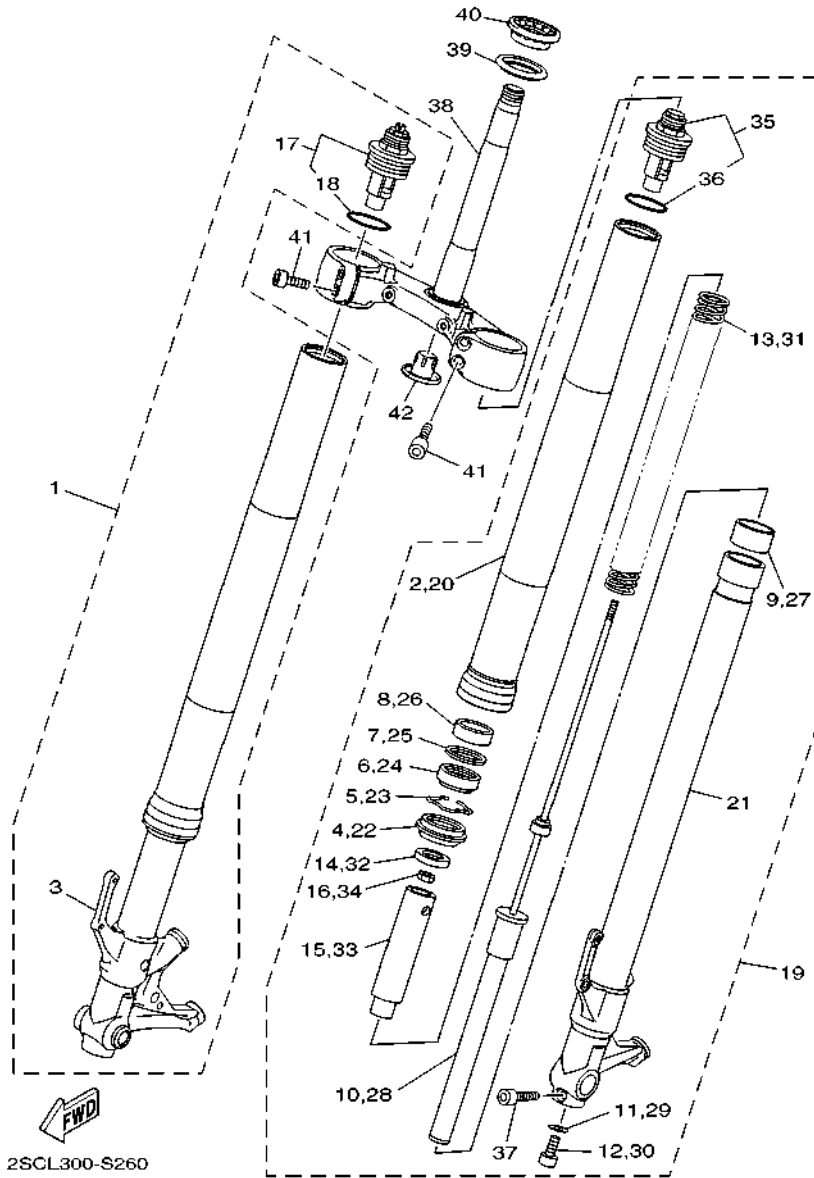
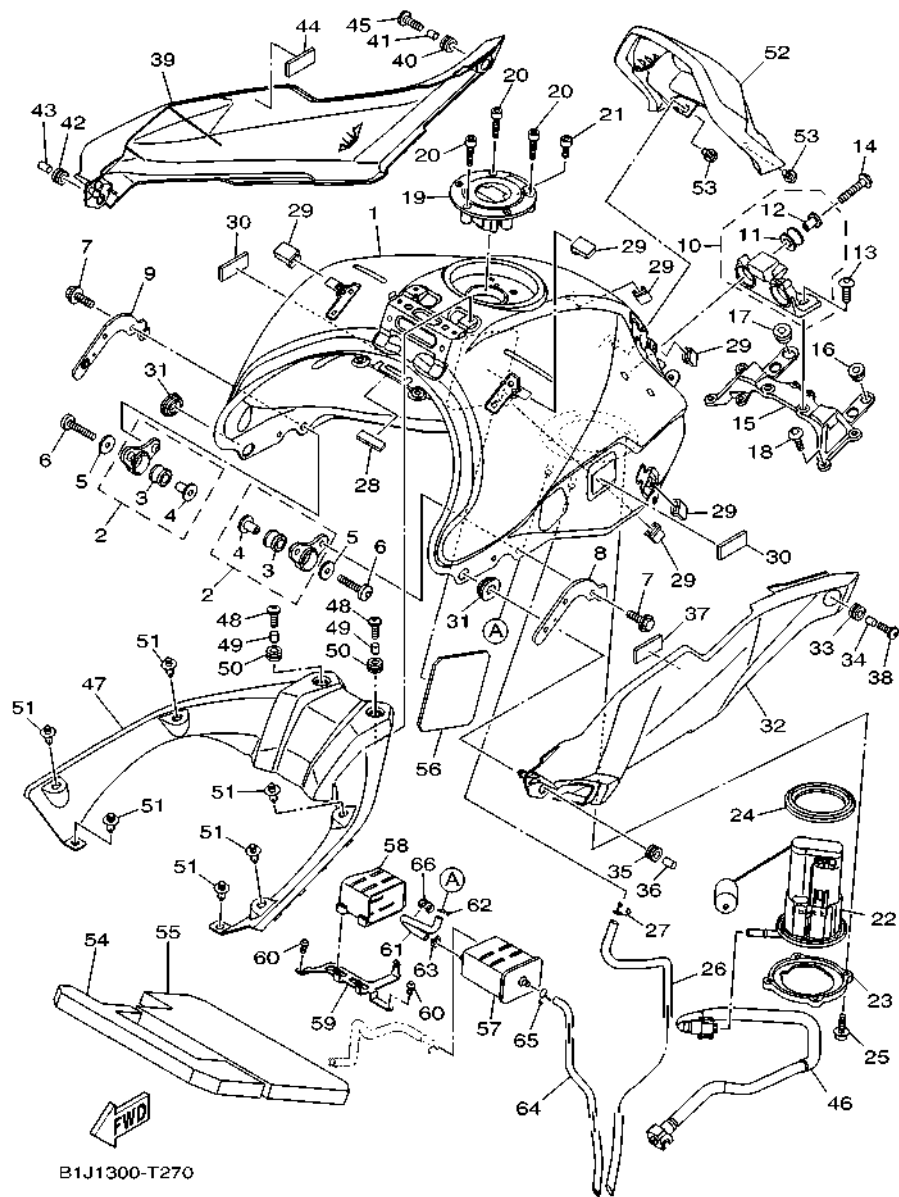

FIG. 26 FRONT FORK

REF. NO.	PART NO.	DESCRIPTION	BOS2	REMARKS
28	B1J-23170-00	.CYLINDER COMP., FRONT FORK	1	
29	509-23158-L0	.GASKET	1	(KYB)
30	278-23181-50	.BOLT, HEXAGON SOCKET HEAD	1	
31	2PP-23141-00	.SPRING, FRONT FORK	1	
32	5VY-12277-00	.WASHER	1	
33	1RC-23118-00	.SPACER	1	
34	3LC-23357-00	.NUT	1	
35	BS2-23111-00	.BOLT, CAP	1	
36	3XJ-23147-L0	..O-RING	1	
37	91314-08035	.BOLT, HEXAGON SOCKET HEAD	1	
38	2PP-23340-00	UNDER BRACKET COMP.	1	
39	3FV-23462-00	SEAL, STEERING	1	
40	93399-99932	BEARING	1	
41	91314-08030	BOLT, HEXAGON SOCKET HEAD	4	
42	4KM-23123-01	COVER, UNDER 1	1	



B1J1300-T270

FIG. 27 FUEL TANK

REF. NO.	PART NO.	DESCRIPTION	BOS2	REMARKS
1	2PP-YK241-00-PB	FUEL TANK COMP.	1	UR FOR BNS4
	2PP-24110-00-PC	FUEL TANK COMP.	1	UR FOR MDPBM1
2	23P-24104-01	TANK BRACKET ASSY	2	
3	90480-18008	.GROMMET	1	
4	90387-06266	.COLLAR	1	
5	90201-06072	WASHER, PLATE	2	
6	92012-06035	BOLT, BUTTON HEAD	2	
7	90119-06200	BOLT, WITH WASHER	4	
8	2PP-2411F-00	PLATE, FITTING	1	
9	2PP-2411L-00	HOOK TANK FITTING	1	
10	2PP-24105-00	TANK BRACKET ASSY 2	1	
11	3D7-24339-00	.GROMMET	2	
12	90387-06136	.COLLAR	2	
13	90111-06136	BOLT,HEX. SOCKET BUTTON	2	
14	95812-06025	BOLT, FLANGE	2	
15	2PP-2413Y-00	BRACKET, TANK FITTING	1	
16	90480-13398	GROMMET	1	
17	90480-01559	GROMMET	1	
18	92017-06020	BOLT, BUTTON HEAD	4	
19	39P-24602-10	CAP ASSY	1	
20	90110-05112	BOLT, HEXAGON SOCKET HEAD	3	
21	91312-05010	BOLT, HEXAGON SOCKET HEAD	1	
22	1RC-13907-00	FUEL PUMP COMP.	1	
23	1RC-24491-00	BRACKET, FUEL PUMP	1	
24	1RC-24486-00	O-RING	1	
25	90110-05028	BOLT, HEXAGON SOCKET HEAD	4	
26	1RC-24315-00	PIPE 5	1	

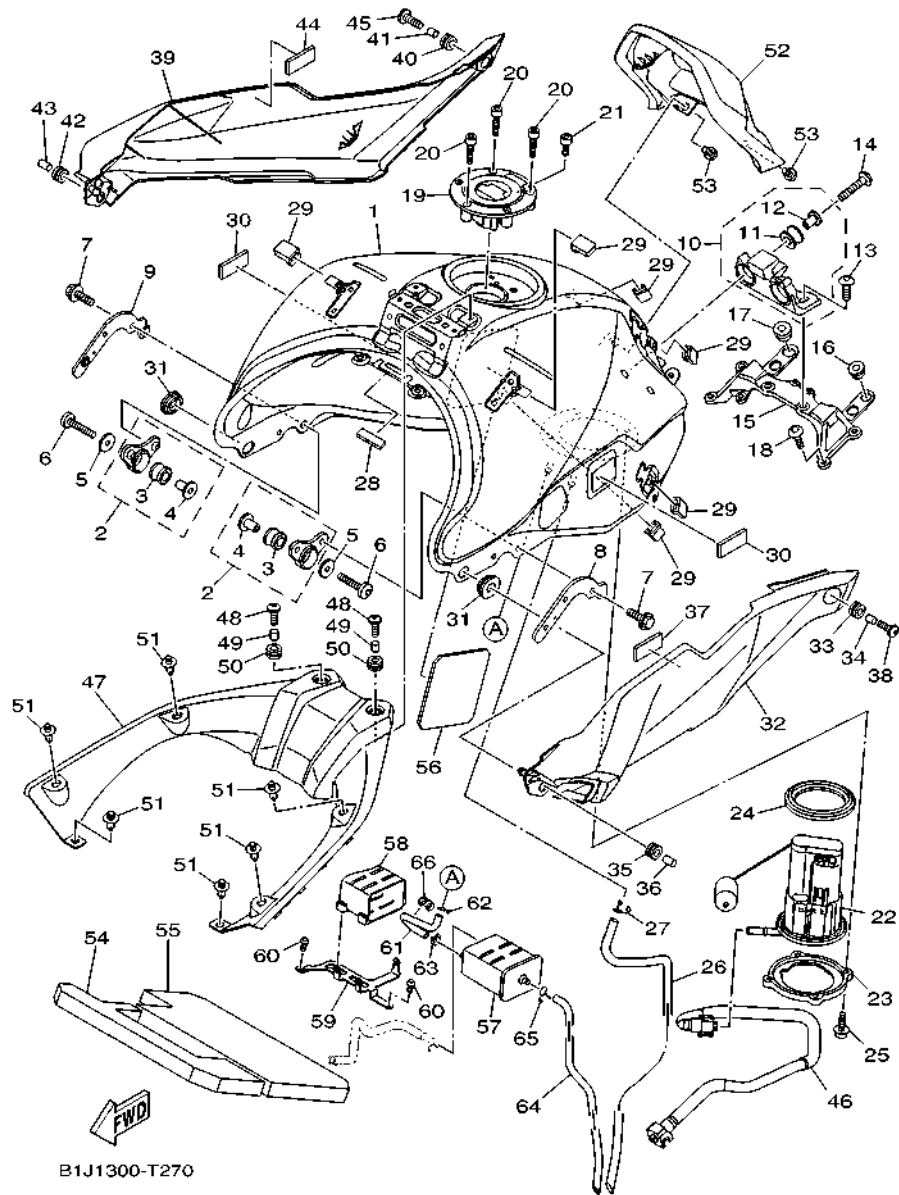

FIG. 27 FUEL TANK

REF. NO.	PART NO.	DESCRIPTION	BOS2				REMARKS
27	90467-09006	CLIP	1				
28	2S3-28347-00	MOLE 3	1				
29	5PW-2411J-01	DAMPER, SIDE COVER	6				
30	2PP-2411G-00	HOOK, SIDE COVER 1	2				
31	90480-01558	GROMMET	2				
32	B5C-24129-00	COVER, SIDE 1	1				
33	90480-13018	GROMMET	1				
34	90387-0611W	COLLAR	1				
35	90480-13018	GROMMET	1				
36	90387-06026	COLLAR	1				
37	2PP-2411G-00	HOOK, SIDE COVER 1	1				
38	90111-05007	BOLT,HEX. SOCKET BUTTON	1				
39	B5C-24139-00	COVER, SIDE 2	1				
40	90480-13018	GROMMET	1				
41	90387-0611W	COLLAR	1				
42	90480-13018	GROMMET	1				
43	90387-06026	COLLAR	1				
44	2PP-2411G-00	HOOK, SIDE COVER 1	1				
45	90111-05007	BOLT,HEX. SOCKET BUTTON	1				
46	1RC-13971-10	PIPE, FUEL 1	1				
47	B5C-241B1-00	COVER, TANK	1				
48	90111-05007	BOLT,HEX. SOCKET BUTTON	2				
49	90387-0611W	COLLAR	2				
50	90480-13018	GROMMET	2				
51	90269-07007	RIVET	6				
52	B5C-24141-00	PROTECTOR, FUEL TANK	1				
53	90111-05002	BOLT,HEX. SOCKET BUTTON	2				

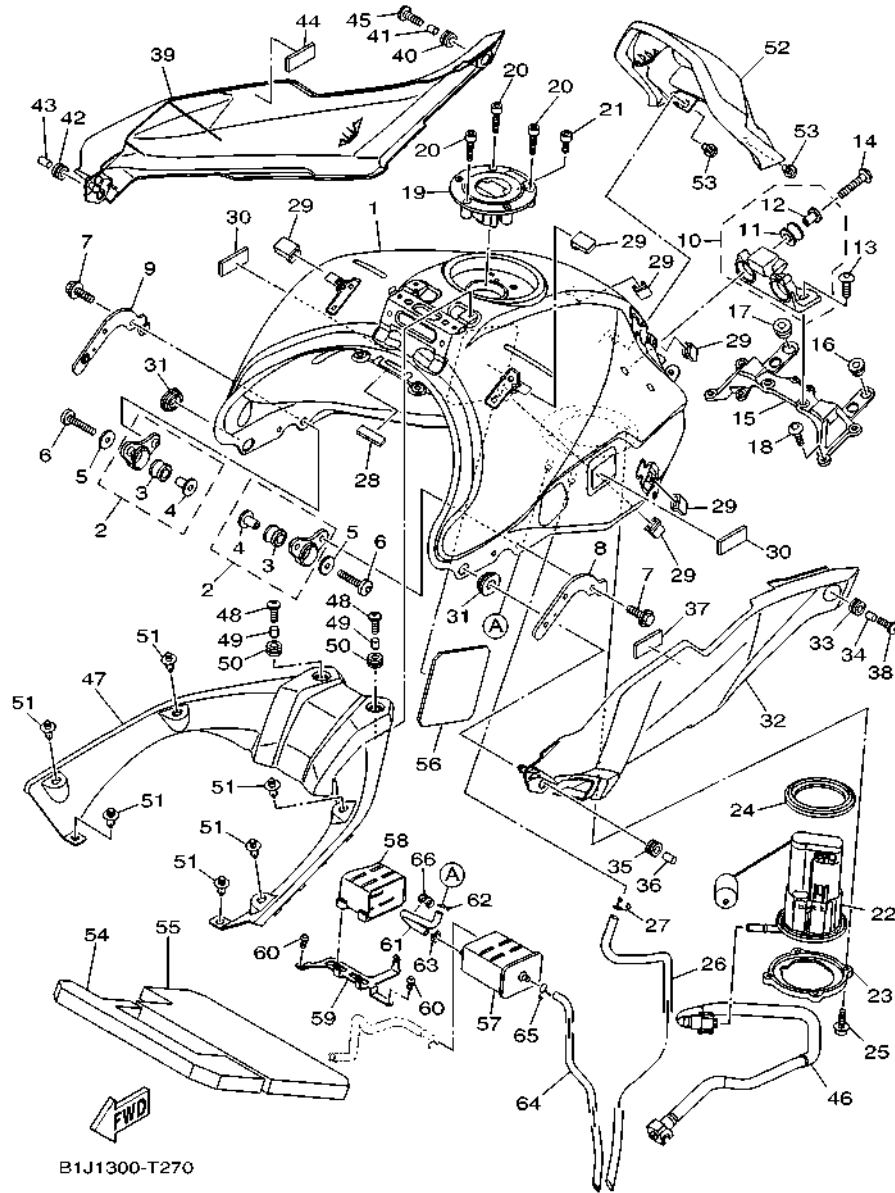

FIG. 27 FUEL TANK

REF. NO.	PART NO.	DESCRIPTION	BOS2				REMARKS
54	2PP-2414H-00	DAMPER, PLATE 1	1				
55	2PP-2414J-00	DAMPER, PLATE 2	1				
56	BS2-24141-00	PROTECTOR, FUEL TANK	1				
57	2CR-24170-00	CANISTER ASSY	1				
58	B90-24183-00	DAMPER, LOCATING 3	1				
59	B1J-2419F-00	BRACKET, CANISTOR	1				
60	92012-06012	BOLT, BUTTON HEAD	2				
61	B90-24313-00	PIPE 3	1				
62	90467-09006	CLIP	1				
63	90467-09026	CLIP	1				
64	BS2-24321-00	PIPE 10	1				
65	90467-10041	CLIP	1				
66	90464-09M31	CLAMP	1				

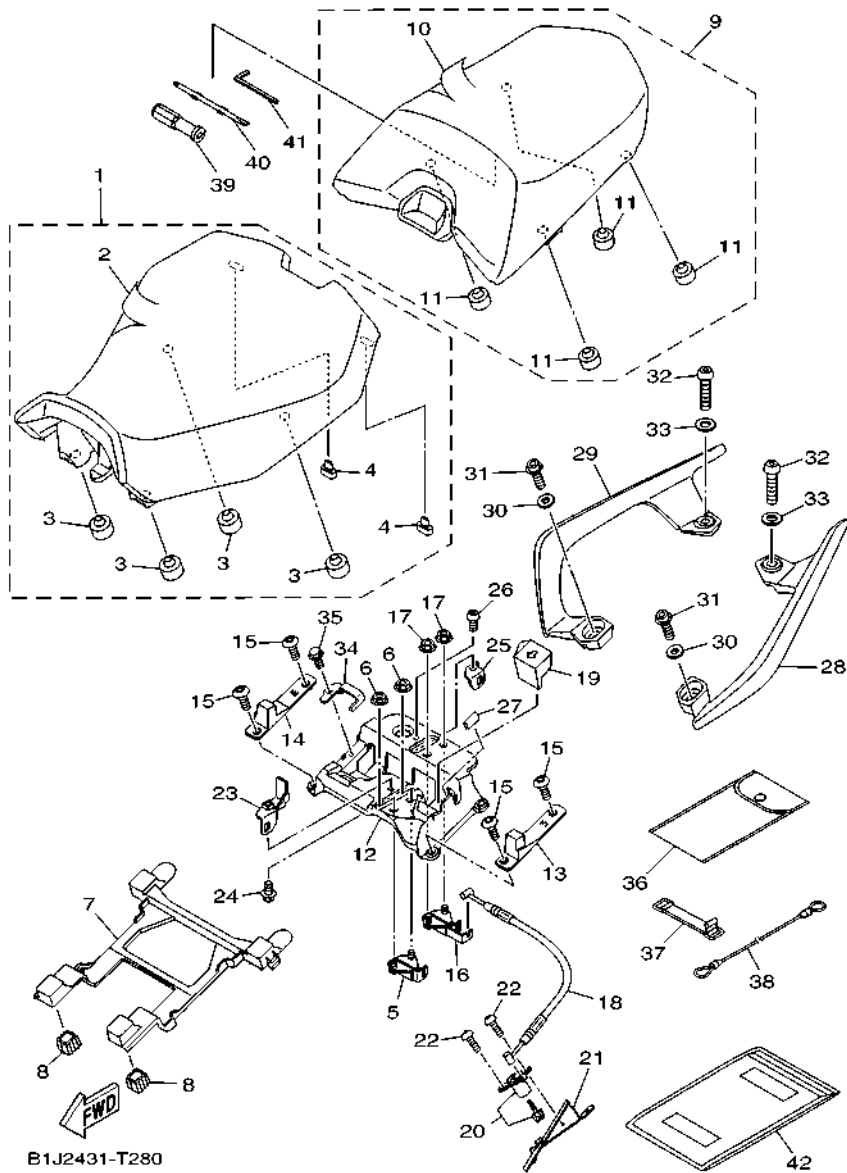
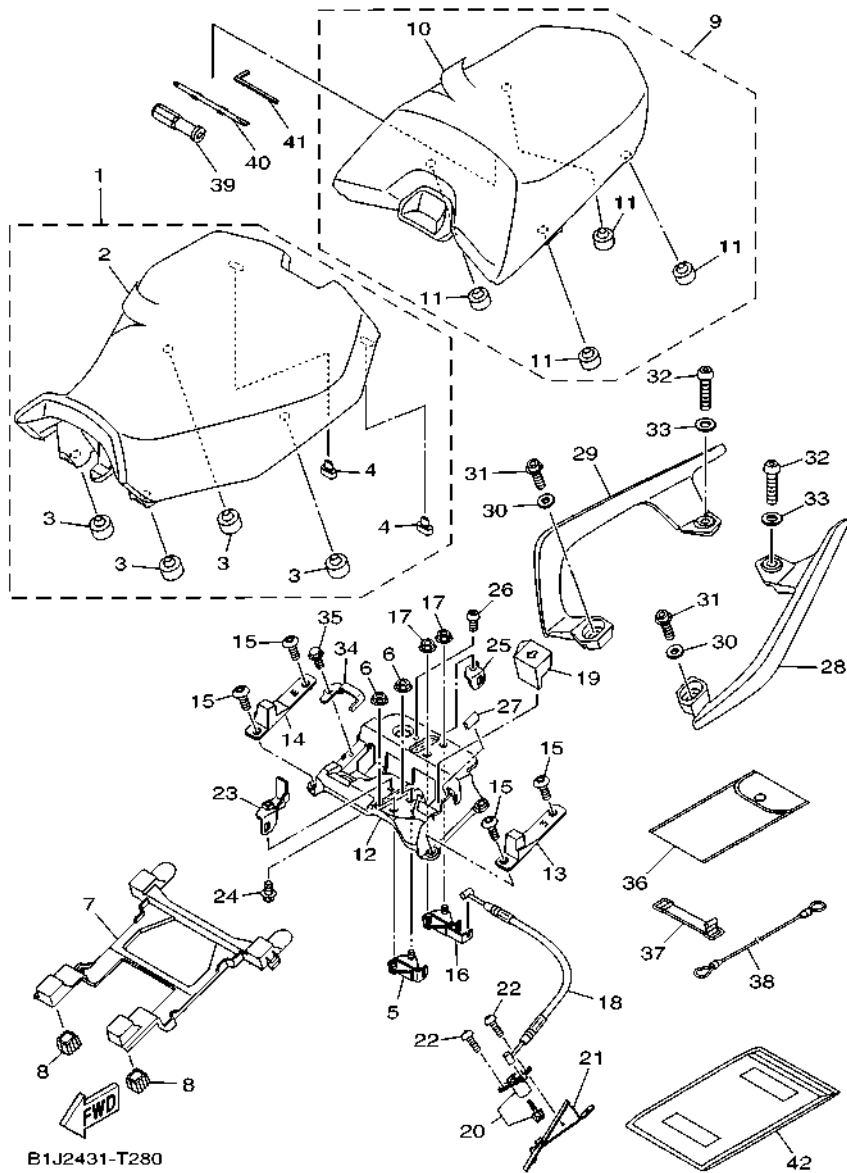

FIG. 28 SEAT

REF. NO.	PART NO.	DESCRIPTION	BOS2	REMARKS
1	B5C-24710-00	SINGLE SEAT ASSY	1	UR FOR BNS4
	B5C-24710-20	SINGLE SEAT ASSY	1	UR FOR MDPBM1
2	B5C-2470F-20	.SEAT COVER COMP.	1	
3	371-27114-00	.STOPPER, MAIN STAND	4	
4	B5C-24741-00	.PAD, SEAT	2	
5	3P6-24780-00	SEAT LOCK ASSY	1	
6	95702-06500	NUT, FLANGE	2	
7	2PP-24708-00	SEAT BRACKET ASSY	1	
8	2PP-24723-00	DAMPER, SEAT	2	
9	B5C-24750-00-P0	TANDEM SEAT ASSY	1	MLNM3 FOR BNS4
	B5C-24750-20-P0	TANDEM SEAT ASSY	1	MLNM3 FOR MDPBM1
10	B5C-2470H-20	.SEAT COVER COMP. ,2	1	
11	278-27114-00	.STOPPER, MAIN STAND	4	
12	2PP-2478X-01	BRACKET, SEAT LOCK	1	
13	B5C-24797-00	BRACKET, SEAT BACK	1	
14	B5C-2479L-00	BRACKET, SEAT BACK 2	1	
15	90111-06053	BOLT,HEX. SOCKET BUTTON	4	
16	4BP-24780-00	SEAT LOCK ASSY	1	
17	95702-06500	NUT, FLANGE	2	
18	B5C-2479D-00	WIRE, SEAT LOCK 2	1	
19	2SC-2482H-00	CAP	1	
20	2TV-W2470-00	ROTOR SET	1	
21	B5C-2479K-00	PLATE, LOCK	1	
22	92012-06012	BOLT, BUTTON HEAD	2	
23	2PP-2475H-00	BRACKET, SEAT LEVER 1	1	
24	90105-06057	BOLT, FLANGE	1	
25	2PP-2475J-00	BRACKET, SEAT LEVER 2	1	



B1J2431-T280

FIG. 28 SEAT

REF. NO.	PART NO.	DESCRIPTION	BOS2	REMARKS
26	90111-06065	BOLT,HEX. SOCKET BUTTON	1	
27	34B-24785-00	MOLD	1	
28	B5C-2474A-00	ASSIST, GRIP	1	
29	B5C-2474W-00	ASSIST,GRIP 2	1	
30	92907-08200	WASHER	2	
31	90109-087F1	BOLT	2	
32	92017-10040	BOLT, BUTTON HEAD	2	
33	92907-10200	WASHER, PLAIN	2	
34	2PP-2115J-00	BRACKET, HELMET HANGER	1	
35	95024-06012	BOLT, FLANGE (SMALL HEAD)	1	
36	B1J-28100-00	TOOL KIT	1	
37	3TJ-82131-00	BAND, BATTERY	1	
38	20S-21308-00	HELMET HANGER	1	
39	2H7-28151-00	GRIP, DRIVER	1	
40	2GV-28152-00	DRIVER	1	
41	23P-28164-00	WRENCH, HEXAGON 8	1	
42	4KG-28186-10	POUCH	1	

FIG. 29 FRONT WHEEL

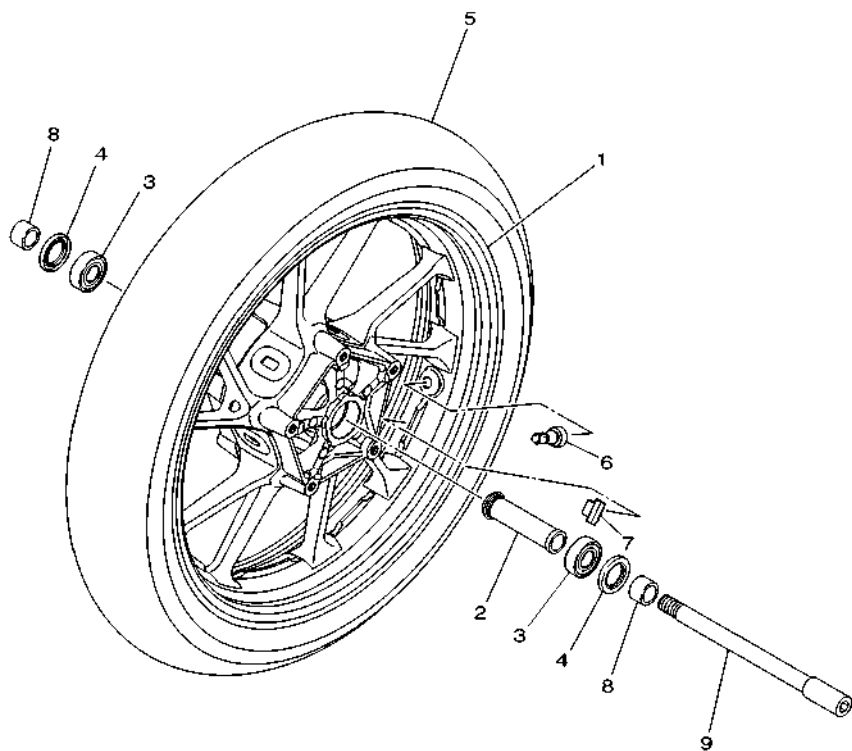

FWD
2SCL300-S290

REF. NO.	PART NO.	DESCRIPTION	BOS2		REMARKS
1	2SC-25168-00-0X	CAST WHEEL, FRONT	1		LGB/HTR FOR BNS4
	2SC-25168-00-98	CAST WHEEL, FRONT	1		LGB FOR MDPBM1
2	2PP-25117-00	SPACER, BEARING	1		
3	93306-20352	BEARING	2		
4	93102-25017	OIL SEAL	2		
5	94112-17130	TIRE(120/70ZR17 M/C 58W D222F)	1		DUNLOP
6	93900-00030	VALVE, RIM (TR412)	1		TAIHEIYO
7	5MT-25398-00	BALANCER, WHEEL (10G)	1		UR
	5MT-25398-10	BALANCER, WHEEL (20G)	1		UR
	5MT-25398-20	BALANCER, WHEEL (30G)	1		UR
8	90387-17017	COLLAR	2		
9	1RC-25181-00	AXLE, WHEEL	1		

FIG. 30 FRONT BRAKE CALIPER

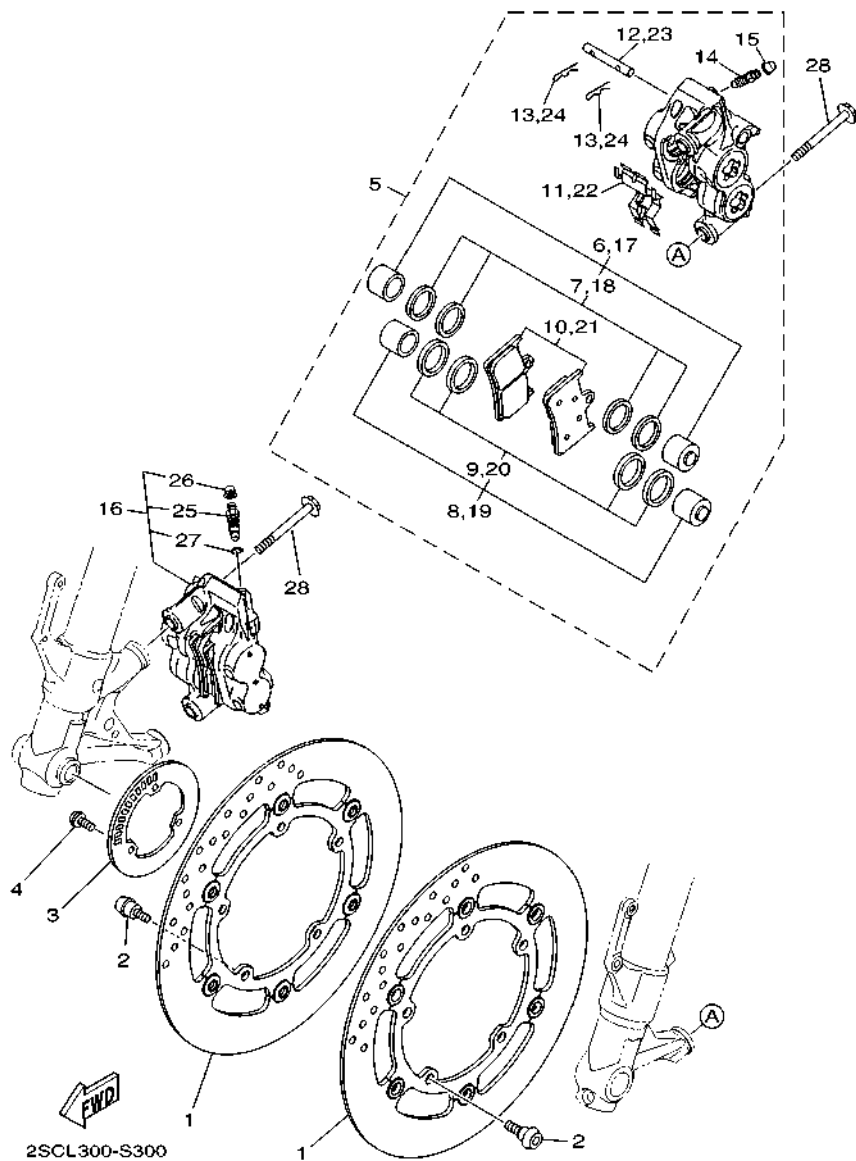

2SCL300-S300

REF. NO.	PART NO.	DESCRIPTION	BOS2				REMARKS
1	1RC-2581T-00	DISK BRAKE ASSY	2				
2	90109-064G6	BOLT	10				
3	2DR-2517G-00	ROTOR, SENSOR	1				
4	90149-05029	SCREW	3				
5	1RC-2580T-00	CALIPER ASSY (LEFT)	1				
6	4SV-25802-10	.PISTON ASSY, CALIPER	1				
7	3GM-25803-10	..CALIPER SEAL KIT	1				
8	4SV-25802-00	.PISTON ASSY, CALIPER	1				
9	3MA-25803-10	..CALIPER SEAL KIT	1				
10	5SL-25805-00	.BRAKE PAD KIT	1				
11	13S-25919-00	.SUPPORT, PAD	1				
12	4SV-25924-00	.PIN, PAD	1				
13	3GM-25925-00	.CLIP	2				
14	1J3-25824-00	.SCREW, BLEED	1				
15	306-25825-01	.CAP	1				
16	2DR-2580U-00	CALIPER ASSY (RIGHT)	1				
17	4SV-25802-10	.PISTON ASSY, CALIPER	1				
18	3GM-25803-10	..CALIPER SEAL KIT	1				
19	4SV-25802-00	.PISTON ASSY, CALIPER	1				
20	3MA-25803-10	..CALIPER SEAL KIT	1				
21	5SL-25805-00	.BRAKE PAD KIT	1				
22	13S-25919-00	.SUPPORT, PAD	1				
23	4SV-25924-00	.PIN, PAD	1				
24	3GM-25925-00	.CLIP	2				
25	5VS-25824-00	.SCREW, BLEED	1				
26	306-25825-01	.CAP	1				
27	5VS-25975-00	.RUBBER, BUSHING	1				

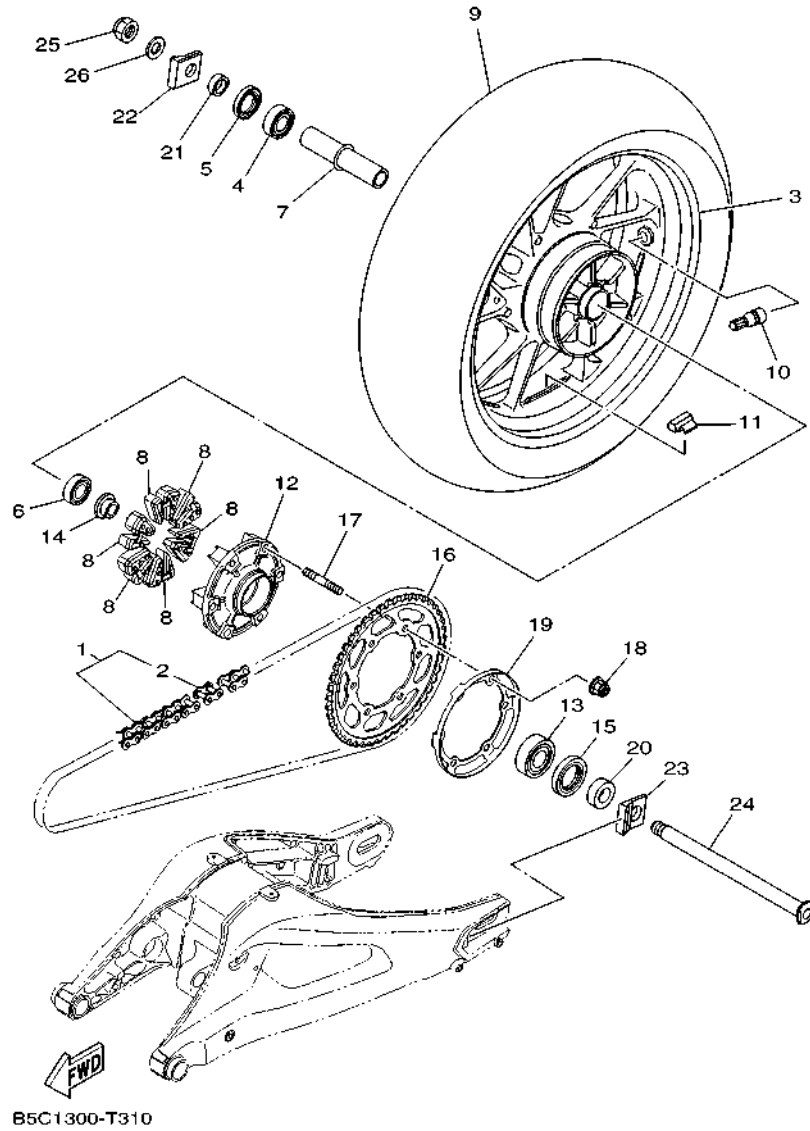

FIG. 31 REAR WHEEL

REF. NO.	PART NO.	DESCRIPTION	BOS2	REMARKS
1	94A40-05118	SET, CHAIN (DID525V11-118)	1	
2	94682-4703R	.JOINT, CHAIN (DID525V11 ZJ)	1	
3	2SC-25338-00-0X	CAST WHEEL, REAR	1	LGB/HTR FOR BNS4
	2SC-25338-00-98	CAST WHEEL, REAR	1	LGB FOR MDPBM1
4	93306-20480	BEARING	1	
5	93102-28022	OIL SEAL	1	
6	93306-00416	BEARING	1	
7	2PP-25317-00	SPACER, BEARING	1	
8	1RC-25364-00	DAMPER	6	
9	94118-17381	TIRE(180/55ZR17 M/C 73W D222)	1	DUNLOP
10	93900-00030	VALVE, RIM (TR412)	1	TAIHEIYO
11	5MT-25398-00	BALANCER, WHEEL (10G)	1	UR
	5MT-25398-10	BALANCER, WHEEL (20G)	1	UR
	5MT-25398-20	BALANCER, WHEEL (30G)	1	UR
12	5JJ-25366-00	CLUTCH, HUB	1	
13	93306-205B5	BEARING	1	
14	1RC-25383-00	COLLAR, WHEEL	1	
15	93106-40013	OIL SEAL	1	
16	1RC-25445-00	SPROCKET, DRIVEN (45T)	1	
17	90116-10048	BOLT, STUD	6	
18	95602-10200	NUT, S/L FLANGE	6	
19	1RC-2537W-00	BRACKET 1	1	
20	90387-20036	COLLAR	1	
21	90387-20035	COLLAR	1	
22	3SP-25388-00	PULLER, CHAIN 1	1	
23	1RC-25389-00	PULLER, CHAIN 2	1	
24	1RC-25381-00	AXLE, WHEEL	1	

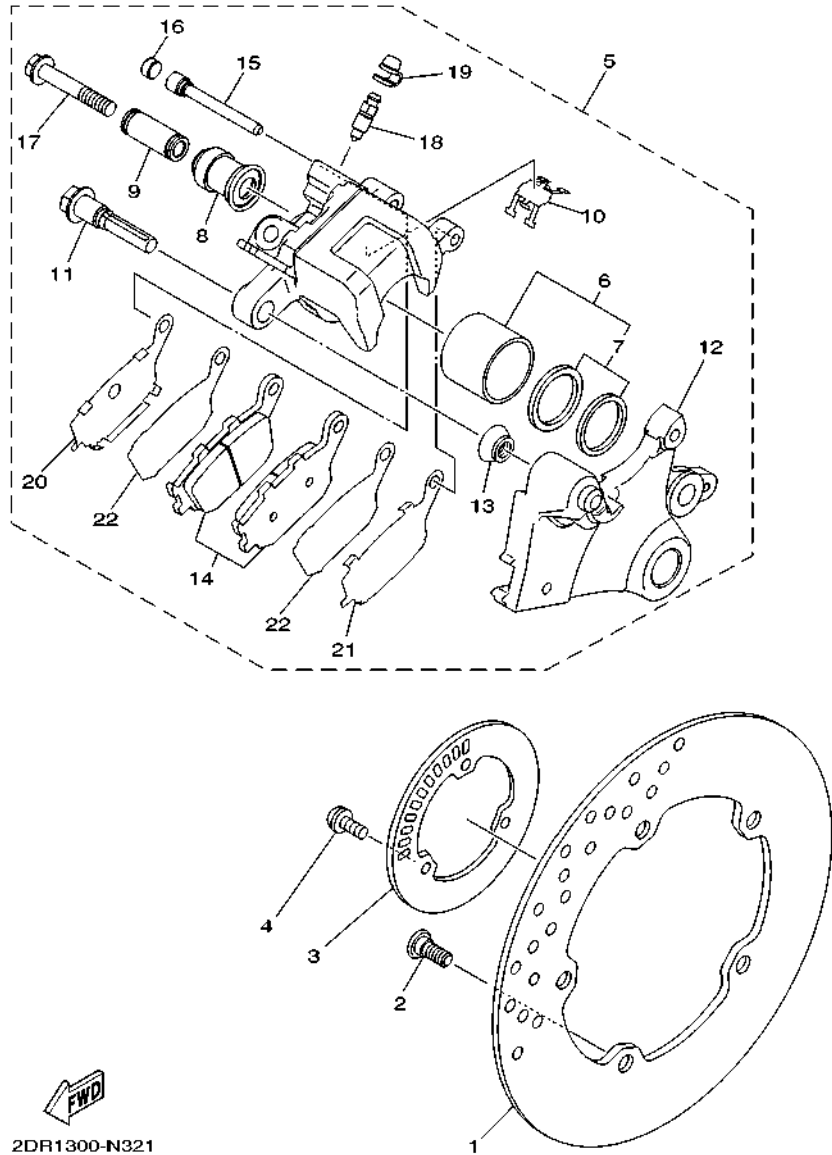

FIG. 32 REAR BRAKE CALIPER

REF. NO.	PART NO.	DESCRIPTION	BOS2				REMARKS
1	1RC-2582W-00	DISK, REAR BRAKE 2	1				
2	90109-08045	BOLT	5				
3	2DR-2517G-00	ROTOR, SENSOR	1				
4	90149-05029	SCREW	3				
5	2DR-2580W-00	CALIPER ASSY, REAR 2	1				
6	5SL-25802-00	.PISTON ASSY, CALIPER	1				
7	5SL-25803-00	..CALIPER SEAL KIT	1				
8	5SL-25917-00	.BOOT, CALIPER	1				
9	5SL-25838-00	.SLEEVE, CALIPER	1				
10	5SL-25919-00	.SUPPORT, PAD	1				
11	5SL-25914-00	.PIN, SLIDE	1				
12	2DR-25921-50	.BRACKET, SUPPORT	1				
13	3JD-25917-00	.BOOT, CALIPER	1				
14	5VX-25806-00	.BRAKE PAD KIT 2	1				
15	8CR-25924-00	.PIN, PAD	1				
16	5DH-25916-00	.PLUG	1				
17	1RC-25926-00	.BOLT	1				
18	8CR-25824-00	.SCREW, BLEED	1				
19	1UY-25825-51	.CAP	1				
20	5SL-25827-00	.SHIM, CALIPER	1				
21	5SL-25827-10	.SHIM, CALIPER	1				
22	5SL-25828-01	.SHIM, CALIPER	2				

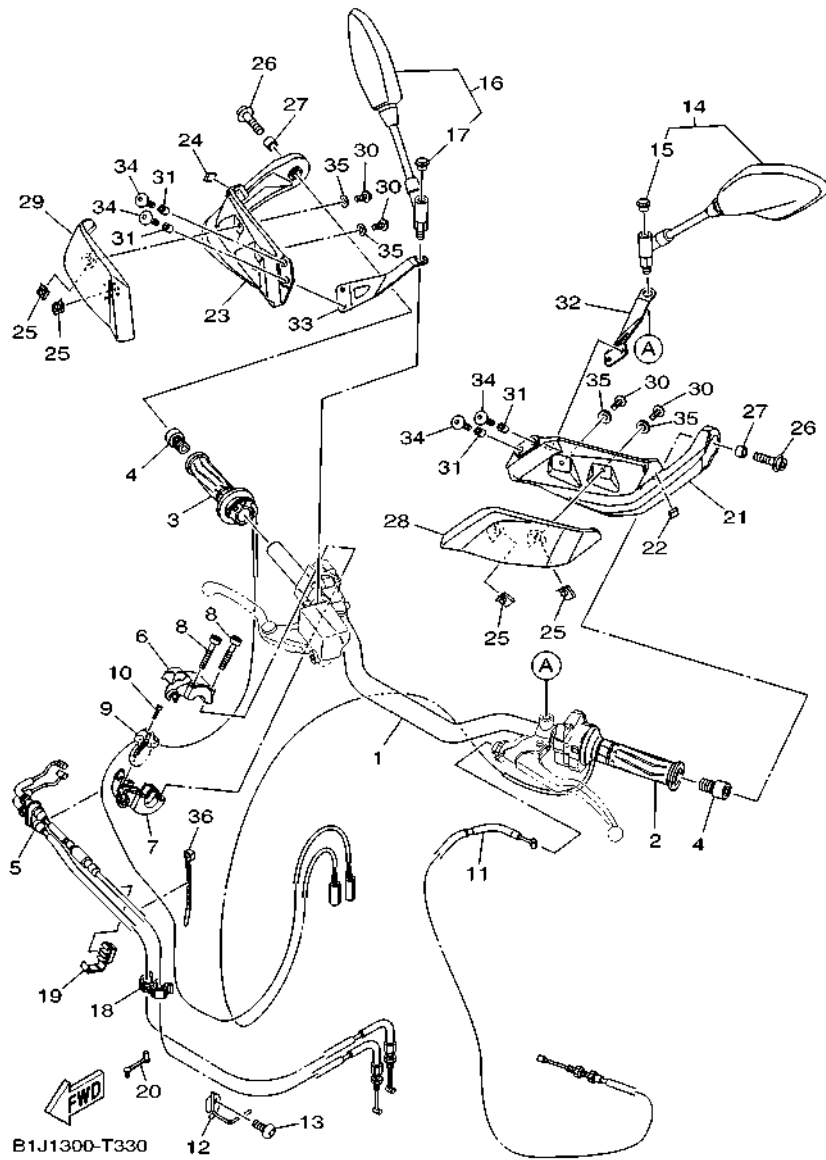
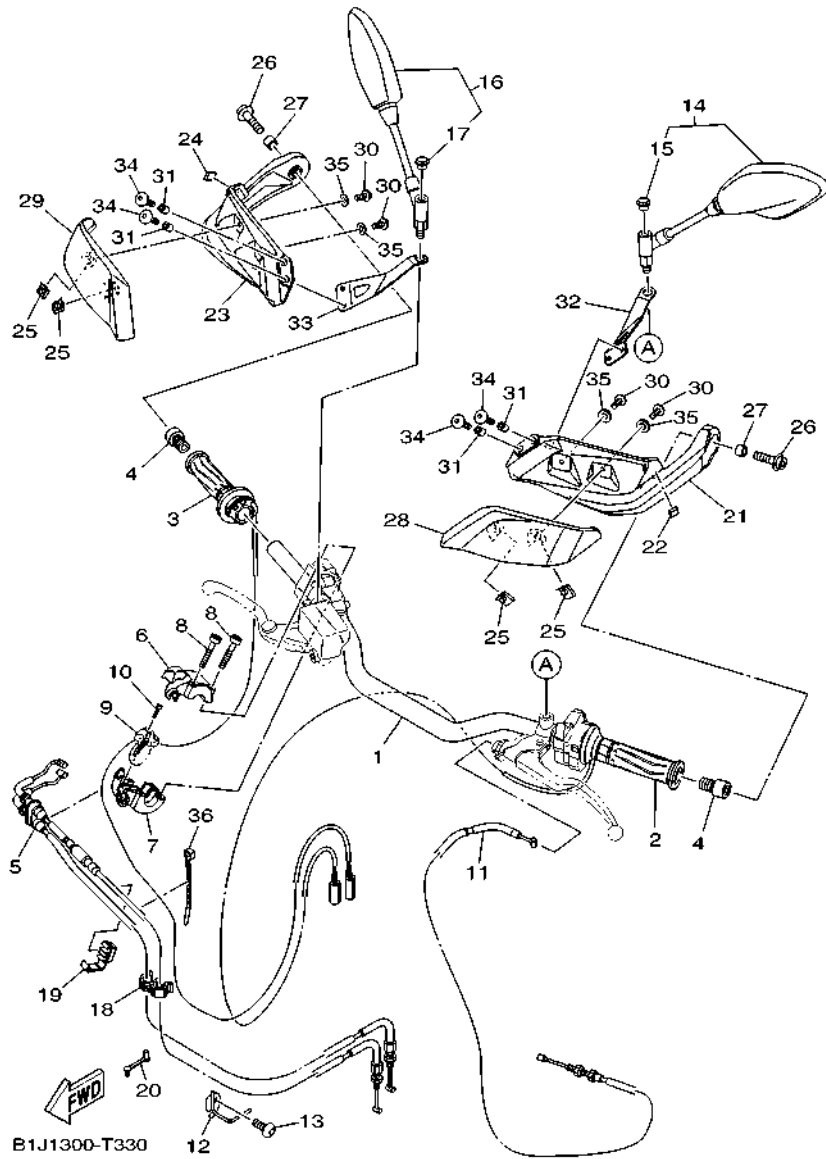

FIG. 33 STEERING HANDLE & CABLE

REF. NO.	PART NO.	DESCRIPTION	BOS2				REMARKS
1	B1J-26111-00	HANDLEBAR	1				
2	B1J-82963-00	GRIP, WARMER (LEFT)	1				
3	B1J-82960-00	GRIP, WARMER	1				
4	B5C-26246-00	END, GRIP	2				
5	B1J-26302-00	THROTTLE CABLE ASSY	1				
6	2D2-26281-01	CAP, GRIP UPPER	1				
7	2PP-26282-00	CAP, GRIP UNDER	1				
8	91317-05035	BOLT, HEX. SOCKET HEAD	2				
9	2D2-2622K-00	PROTECTOR 1	1				
10	90154-03001	SCREW, BINDING	1				
11	2PP-26335-02	CABLE, CLUTCH	1				
12	B90-23857-00	HOLDER	1				
13	92017-06010	BOLT, BUTTON HEAD	1				
14	B5C-26280-00	REAR VIEW MIRROR ASSY (LEFT)	1				
15	23P-26133-00	.CAP	1				
16	B5C-26290-00	REAR VIEW MIRROR ASSY (RIGHT)	1				
17	23P-26133-00	.CAP	1				
18	90464-07M20	CLAMP	1				
19	39P-2627E-00	CLAMP, WIRE	1				
20	90464-05003	CLAMP	1				
21	B5C-26141-00	GUARD, BRUSH 1	1				
22	90520-01001	DAMPER, PLATE	1				
23	B5C-26142-00	GUARD, BRUSH 2	1				
24	90520-01001	DAMPER, PLATE	1				
25	90183-05076	NUT, SPRING	4				
26	90110-08099	BOLT, HEXAGON SOCKET HEAD	2				
27	90387-08114	COLLAR	2				



B1J1300-T330

FIG. 33 STEERING HANDLE & CABLE

REF. NO.	PART NO.	DESCRIPTION	BOS2		REMARKS
28	B5C-26143-00-P3	COVER, HANDLE UPPER 1	1		UR FOR BNS4
	B5C-26143-00-P2	COVER, HANDLE UPPER 1	1		UR FOR MDPBM1
29	B5C-26145-00-P3	COVER, HANDLE UPPER 2	1		UR FOR BNS4
	B5C-26145-00-P2	COVER, HANDLE UPPER 2	1		UR FOR MDPBM1
30	92017-05012	BOLT, BUTTON HEAD	4		
31	90387-05025	COLLAR	4		
32	B1J-26223-00	BRACKET, HANDLE 1	1		
33	B1J-26224-00	BRACKET, HANDLE 2	1		
34	90111-05021	BOLT, HEX. SOCKET BUTTON	4		
35	92907-05200	WASHER	4		
36	90465-10098	CLAMP	1		

FIG. 34 FRONT MASTER CYLINDER

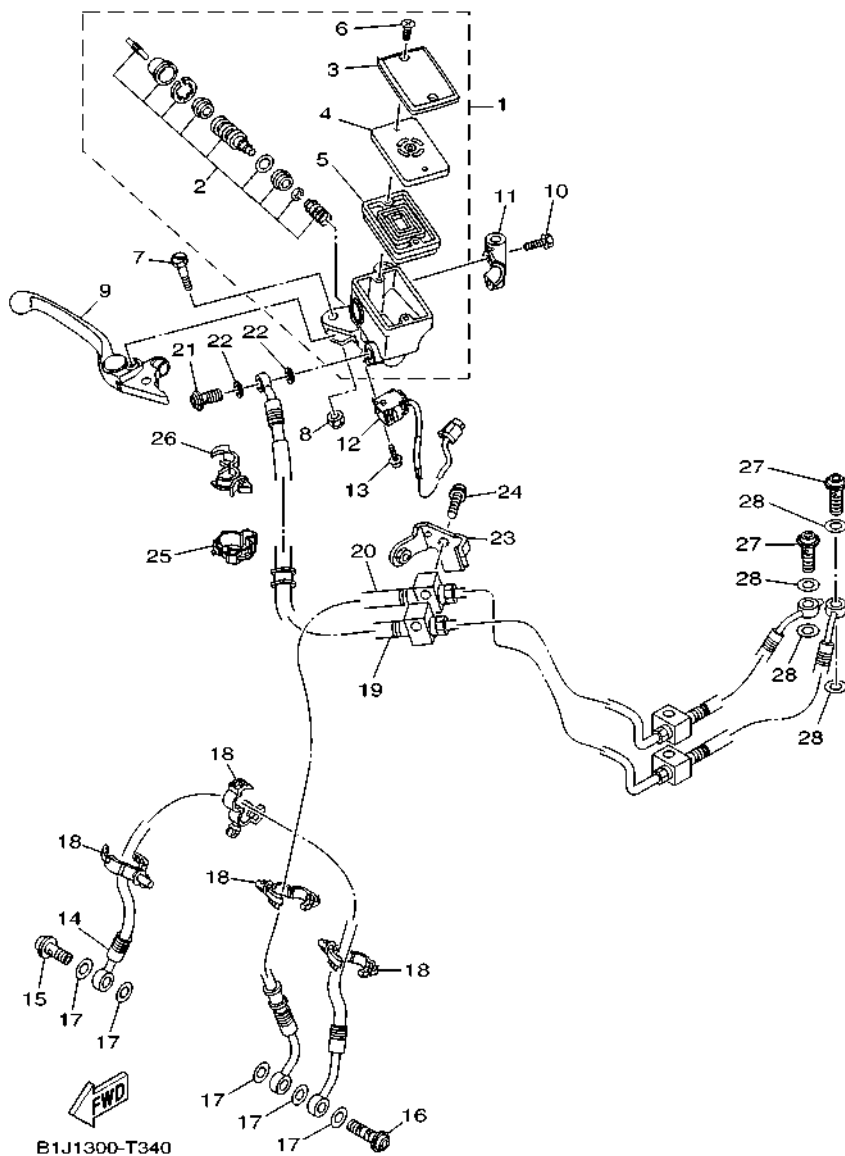

REF. NO.	PART NO.	DESCRIPTION	BOS2				REMARKS
1	BW8-2580A-00	MASTER CYLINDER SUB ASSY 2	1				
2	1WS-25807-00	.CYLINDER KIT, MASTER	1				
3	5VS-25852-00	.CAP, RESERVOIR	1				
4	5VS-25855-00	.BUSH,DIAPHRAGM	1				
5	20S-25854-00	.DIAPHRAGM, RESERVOIR	1				
6	5VS-2589H-00	.SCREW	2				
7	5VS-2589F-00	BOLT, LEVER	1				
8	95617-06100	NUT, SELF-LOCKING	1				
9	5VS-83922-00	LEVER 2	1				
10	95027-06030	BOLT, FLANGE	2				
11	34B-25867-10	BRACKET, MASTER CYLINDER	1				
12	B1J-83980-00	FRONT STOP SWITCH ASSY	1				
13	97602-04214	SCREW, PAN HEAD WITH WASHER	1				
14	2DR-25872-00	HOSE, BRAKE 1	1				
15	90401-10172	BOLT, UNION	1				
16	90401-10042	BOLT, UNION	1				
17	90430-10005	GASKET	5				
18	90464-18002	CLAMP	4				
19	2SC-2584A-01	BRAKE HOSE ASSY	1				
20	2DR-2584B-00	HOSE, BRAKE	1				
21	90401-10172	BOLT, UNION	1				
22	90430-10005	GASKET	2				
23	2DR-85132-00	BRACKET, REFLECTOR 1	1				
24	90105-06192	BOLT, FLANGE	1				
25	90464-12013	CLAMP	1				
26	90464-18246	CLAMP	1				
27	90401-10172	BOLT, UNION	2				

FIG. 34 FRONT MASTER CYLINDER

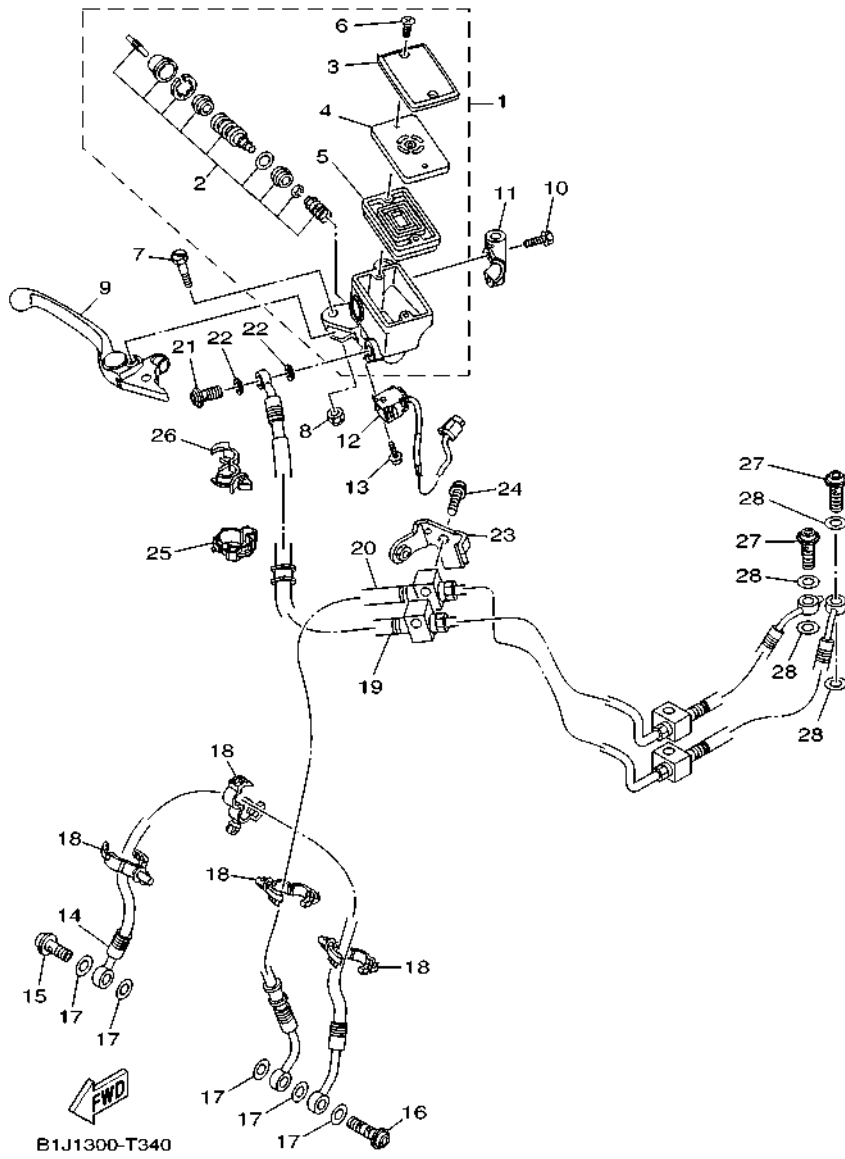

REF. NO.	PART NO.	DESCRIPTION	BOS2				REMARKS
28	90430-10005	GASKET	4				

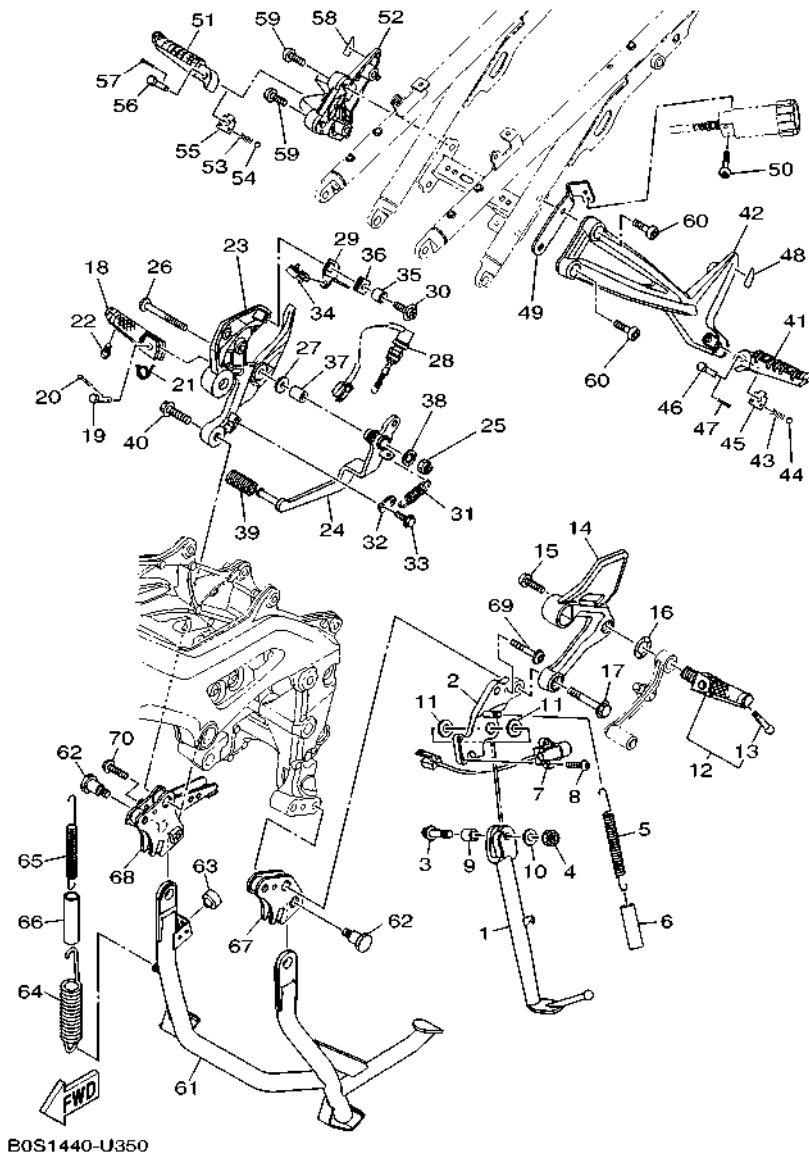
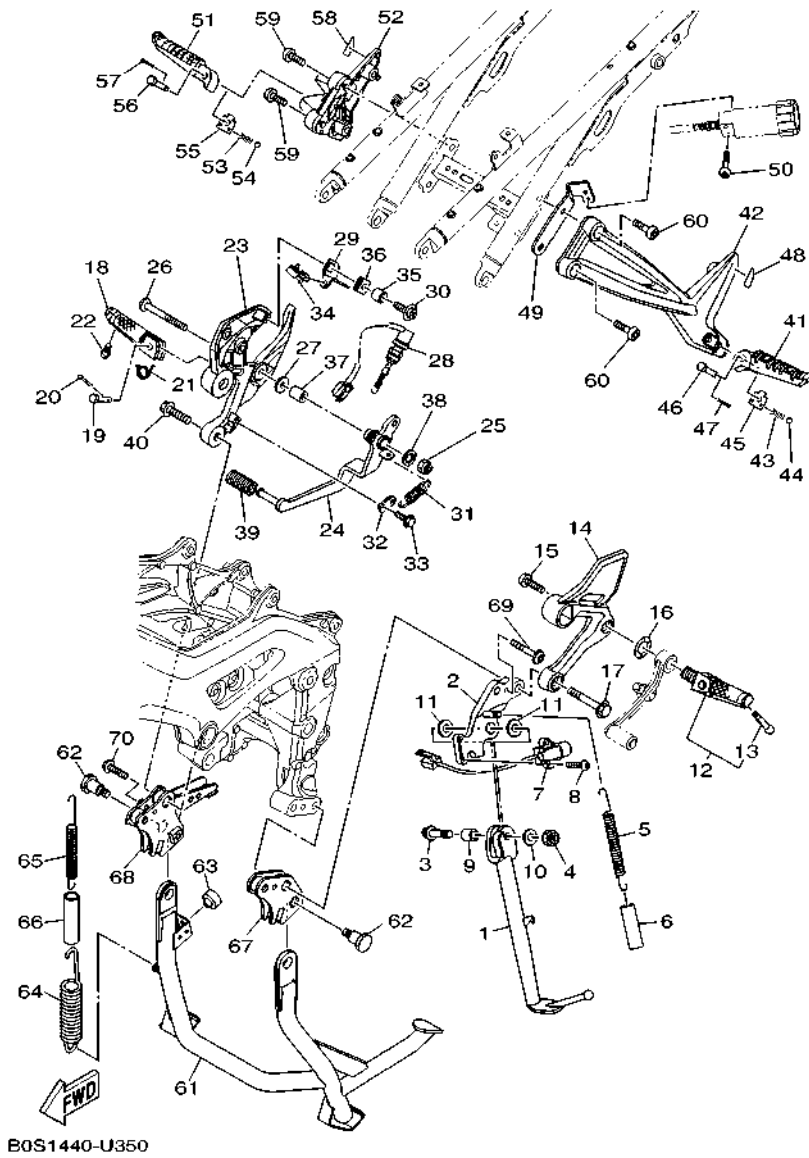

FIG. 35 STAND & FOOTREST

REF. NO.	PART NO.	DESCRIPTION	BOS2				REMARKS
1	1RC-27311-00	STAND, SIDE	1				
2	1RC-27321-00	BRACKET, SIDE STAND	1				
3	90105-10188	BOLT, FLANGE	1				
4	95612-10100	NUT, U	1				
5	90506-20032	SPRING, TENSION	1				
6	90445-197J2	HOSE (L60)	1				
7	1RC-82566-50	SWITCH, SIDE STAND	1				
8	90111-05036	BOLT,HEX. SOCKET BUTTON	2				
9	90387-10050	COLLAR	1				
10	90201-10035	WASHER, PLATE	1				
11	90201-17018	WASHER, PLATE	2				
12	2PP-27410-00	FRONT FOOTREST ASSY (LEFT)	1				
13	90109-08233	.BOLT	1				
14	1RC-27442-00	BRACKET 2	1				
15	90111-10039	BOLT,HEX. SOCKET BUTTON	1				
16	90206-17084	WASHER, WAVE	1				
17	90105-10377	BOLT, FLANGE	1				
18	3XV-27461-02	FOOTREST	1				
19	91701-08040	PIN	1				
20	91402-25015	PIN, COTTER	1				
21	90508-20572	SPRING, TORSION	1				
22	90109-08233	BOLT	1				
23	BS2-27443-00	BRACKET 3	1				
24	2PP-27211-00	PEDAL, BRAKE	1				
25	90185-08089	NUT, SELF-LOCKING	1				
26	90111-08005	BOLT,HEX. SOCKET BUTTON	1				
27	90201-08103	WASHER, PLATE	1				



B0S1440-U350

FIG. 35 STAND & FOOTREST

REF. NO.	PART NO.	DESCRIPTION	BOS2				REMARKS
28	B1J-82530-01	STOP SWITCH ASSY	1				
29	1RC-2144G-00	STAY, STOP SWITCH	1				
30	90159-06150	SCREW, WITH WASHER	1				
31	90506-23008	SPRING, TENSION	1				
32	1RC-27432-00	BRACKET 1	1				
33	95802-06010	BOLT, FLANGE	1				
34	90464-15157	CLAMP	1				
35	90387-06341	COLLAR	1				
36	90480-12607	GROMMET	1				
37	90387-08102	COLLAR	1				
38	90201-08048	WASHER, PLATE	1				
39	5EB-18113-00	COVER, SHIFT PEDAL	1				
40	90105-10252	BOLT, FLANGE	1				
41	B5C-27431-00	FOOTREST, REAR 1	1				
42	B5C-2741L-00	BRACKET 4	1				
43	90501-12743	SPRING, COMPRESSION	1				
44	93501-04011	BALL	1				
45	5VX-27437-00	WASHER, SPECIAL	1				
46	91702-08040	PIN, CLEVIS	1				
47	91401-25015	PIN, COTTER	1				
48	B5C-27498-00	SEAT 1	1				
49	B1J-2115K-00	BRACKET, 1	1				
50	90149-06033	SCREW	2				
51	B5C-27441-00	FOOTREST, REAR 2	1				
52	B5C-2742L-00	BRACKET 5	1				
53	90501-12743	SPRING, COMPRESSION	1				
54	93501-04011	BALL	1				

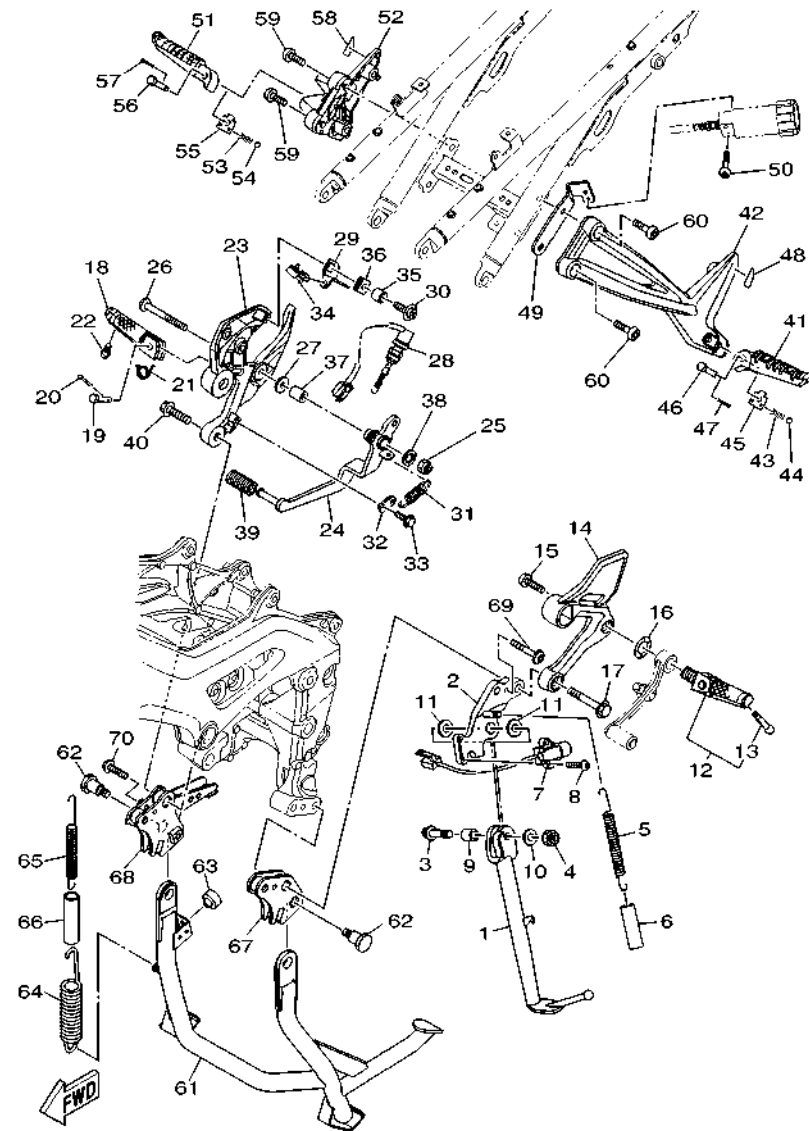

B0S1440-U350

FIG. 35 STAND & FOOTREST

REF. NO.	PART NO.	DESCRIPTION	BOS2				REMARKS
55	5VX-27437-00	WASHER, SPECIAL	1				
56	91702-08040	PIN, CLEVIS	1				
57	91401-25015	PIN, COTTER	1				
58	B5C-27499-00	SEAT 2	1				
59	90111-08057	BOLT,HEX. SOCKET BUTTON	2				
60	90110-08220	BOLT, HEXAGON SOCKET HEAD	2				
61	2PP-27111-00	STAND, MAIN	1				
62	90109-10029	BOLT	2				
63	36C-27114-00	STOPPER, MAIN STAND	1				
64	2PP-27116-00	SPRING, MAIN STAND	1				
65	2PP-27116-10	SPRING, MAIN STAND	1				
66	90445-19003	HOSE	1				
67	2PP-27151-00	BRACKET, MAIN STAND	1				
68	2PP-27152-00	BRACKET, MAIN STAND 2	1				
69	92012-06040	BOLT, BUTTON HEAD	1				
70	92012-06030	BOLT, BUTTON HEAD	1				

FIG. 36 REAR MASTER CYLINDER

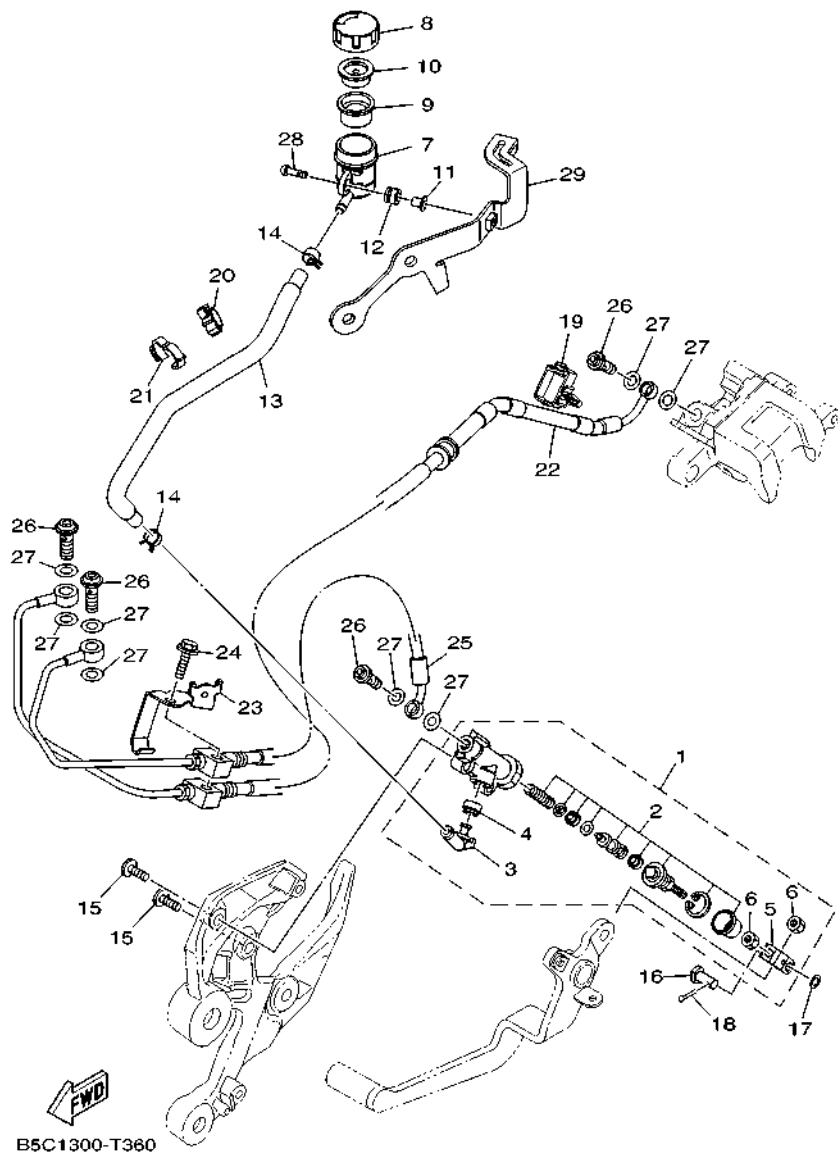

REF. NO.	PART NO.	DESCRIPTION	BOS2				REMARKS
1	56P-2583V-00	RR. MASTER CYLINDER ASSY.	1				
2	56P-25808-50	.CYLINDER KIT, MASTER	1				
3	2D1-2582A-00	.JOINT	1				
4	4BP-2585F-01	.O-RING	1				
5	4BP-27222-02	.JOINT	1				
6	90170-08010	.NUT	2				
7	14B-25894-00	TANK, RESERVOIR	1				
8	2C0-25852-00	CAP, RESERVOIR	1				
9	2VN-25854-00	DIAPHRAGM, RESERVOIR	1				
10	2VN-25855-00	BUSH,DIAPHRAGM	1				
11	90387-05028	COLLAR	1				
12	2C0-26326-00	GROMMET	1				
13	B5C-25895-00	HOSE, RESERVOIR	1				
14	90467-120A3	CLIP	2				
15	90111-08038	BOLT,HEX. SOCKET BUTTON	2				
16	90240-08005	PIN, CLEVIS	1				
17	90201-08066	WASHER, PLATE	1				
18	91401-20012	PIN, COTTER	1				
19	90464-20023	CLAMP	1				
20	90464-18007	CLAMP	1				
21	90464-16003	CLAMP	1				
22	B5C-2581K-00	HOSE, BRAKE 5	1				
23	2DR-85142-00	BRACKET, REFLECTOR 2	1				
24	90105-06192	BOLT, FLANGE	1				
25	2DR-2581J-00	HOSE, BRAKE 4	1				
26	90401-10172	BOLT, UNION	4				
27	90430-10005	GASKET	8				

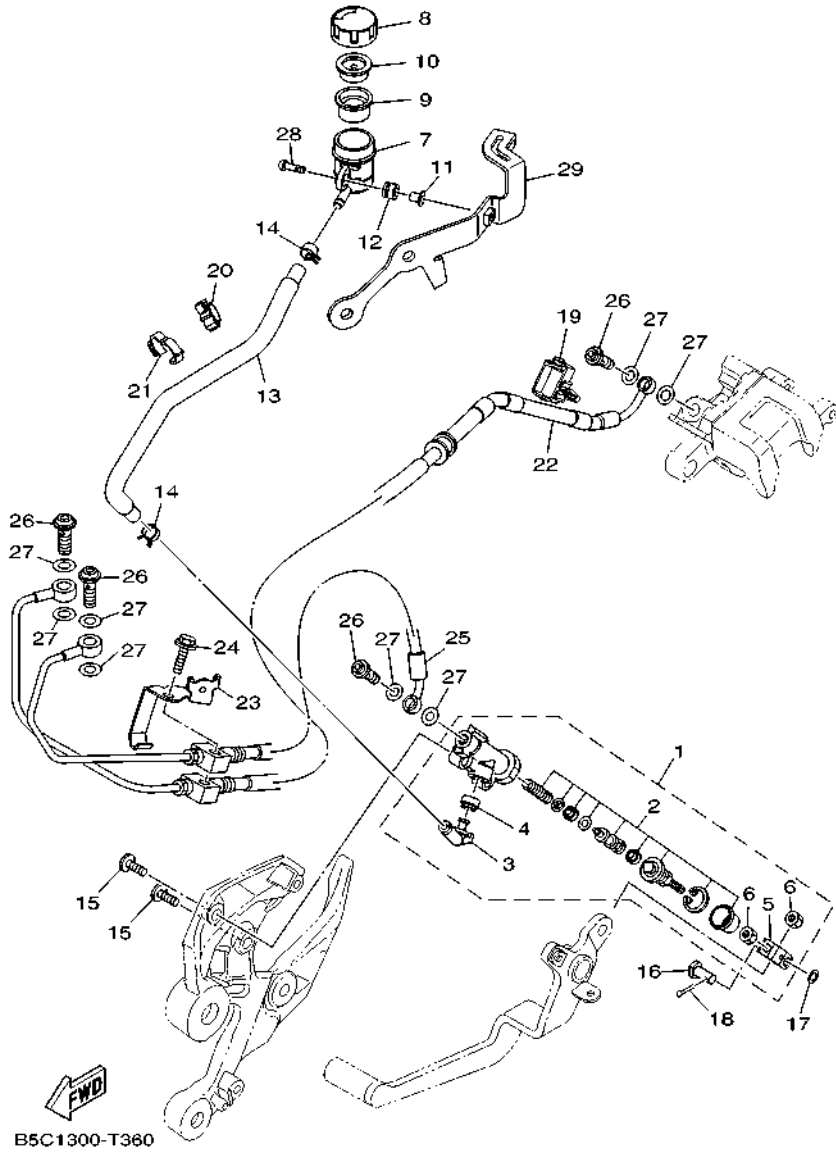
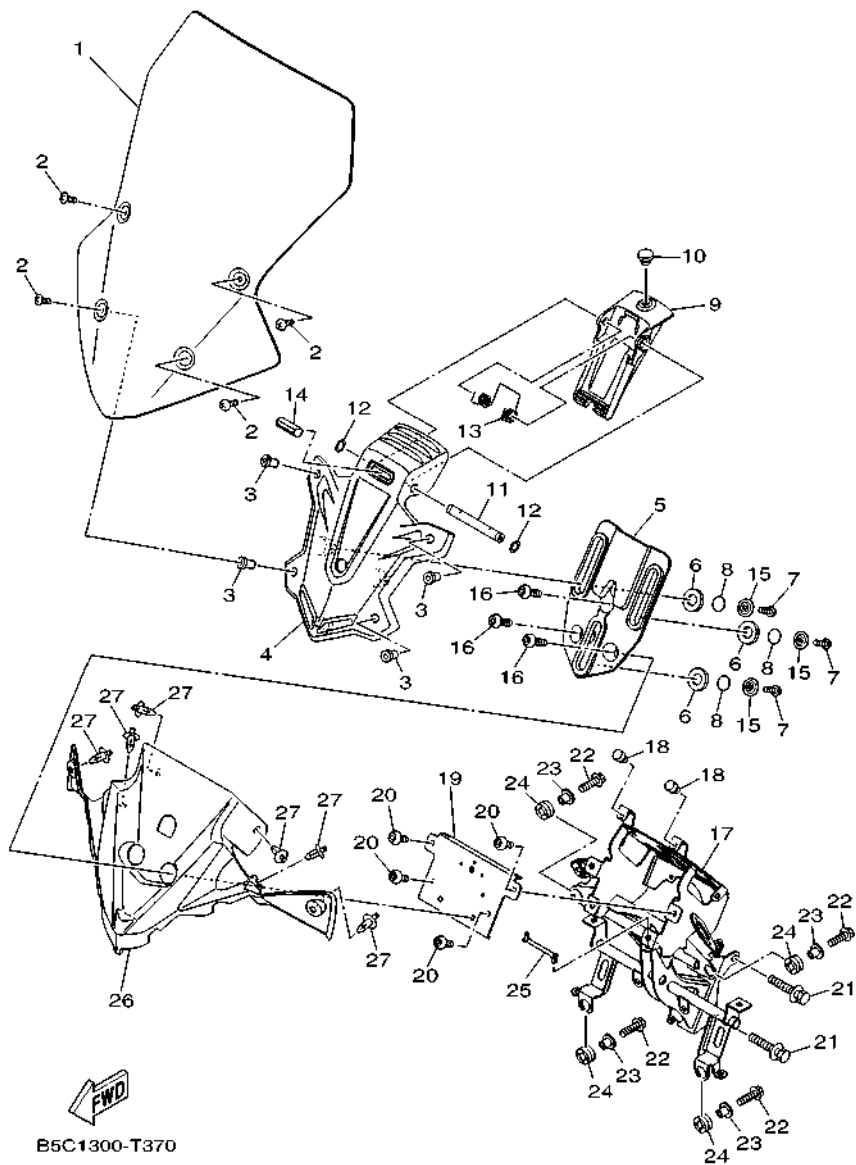

FIG. 36 REAR MASTER CYLINDER

REF. NO.	PART NO.	DESCRIPTION	BOS2				REMARKS
28	90111-05026	BOLT,HEX. SOCKET BUTTON	1				
29	2PP-2582E-00	HOLDER, RESERVE TANK	1				

FIG. 37 WINDSHIELD



B5C1300-T370

REF. NO.	PART NO.	DESCRIPTION	BOS2				REMARKS
1	B5C-28381-00	WINDSHIELD	1				
2	90150-05024	SCREW, ROUND HEAD	4				
3	90179-05003	NUT	4				
4	B5C-2831R-00	STAY, MAIN 1	1				
5	B5C-2831T-00	STAY, SUPPORT 1	1				
6	B5C-28319-00	WASHER	3				
7	92017-05016	BOLT, BUTTON HEAD	3				
8	93210-14MF4	O-RING	3				
9	B5C-2836X-00	KNOB, 1	1				
10	90338-07010	PLUG	1				
11	B5C-2835B-00	SHAFT, 1	1				
12	99009-09800	CIRCLIP	2				
13	B5C-28388-00	SPRING	1				
14	B5C-2836T-00	DAMPER, LOCATING 1	1				
15	B5C-28373-00	COLLAR	3				
16	90111-06029	BOLT,HEX. SOCKET BUTTON	3				
17	B5C-28356-00	STAY 1	1				
18	90338-06007	PLUG	2				
19	B5C-28361-00	PLATE, FRONT	1				
20	92017-06010	BOLT, BUTTON HEAD	4				
21	90119-08179	BOLT, WITH WASHER	2				
22	95807-06025	BOLT, FLANGE	4				
23	90387-065G0	COLLAR	4				
24	3C3-83513-00	DAMPER	4				
25	90464-09026	CLAMP	1				
26	B5C-2836M-00	PANEL, INNER 3	1				
27	90269-07007	RIVET	6				

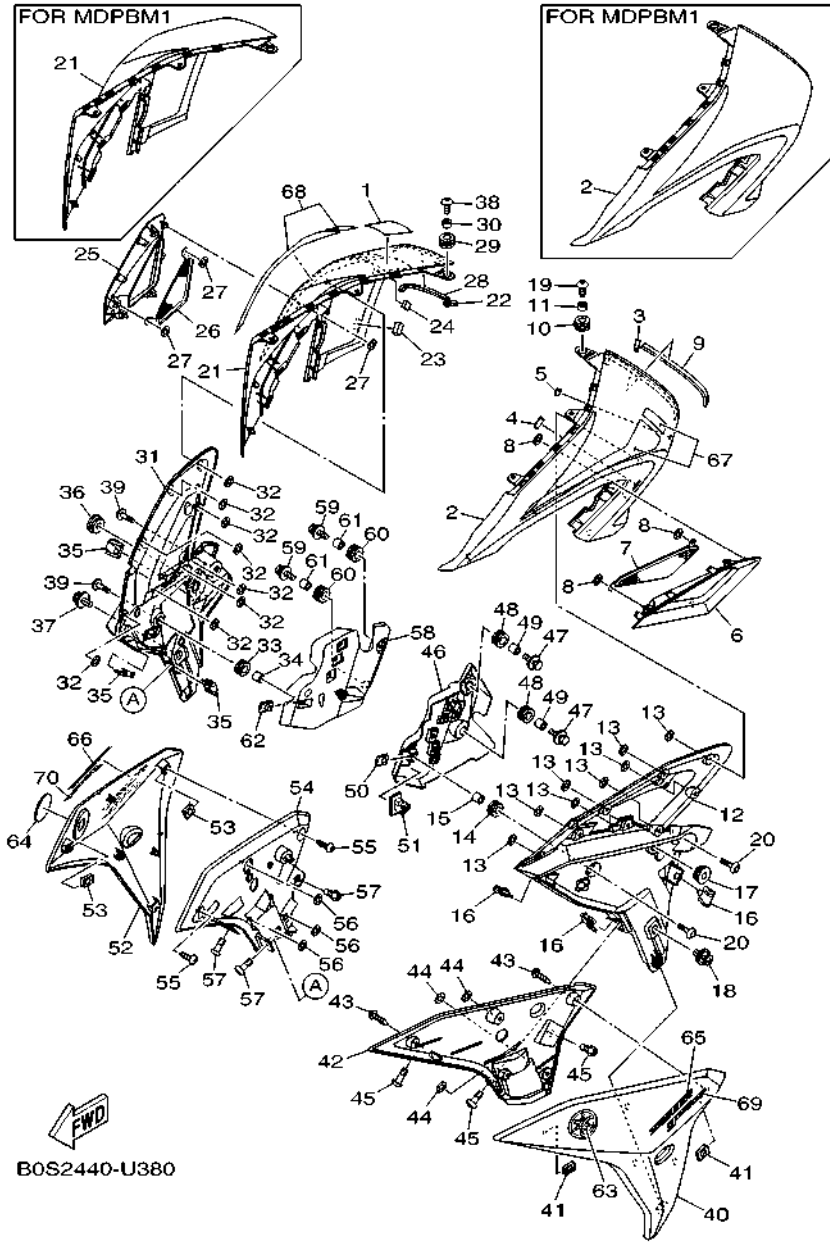

FIG. 38 COWLING

REF. NO.	PART NO.	DESCRIPTION	BOS2	REMARKS
1	4C8-21568-10	LABEL, WARNING	1	
2	B5C-28219-00-P1	COVER 1	1	UR FOR BNS4
	B5C-28219-00-P3	COVER 1	1	UR FOR MDPBM1
3	13S-28415-00	DAMPER 1	1	
4	5B6-23445-00	DAMPER	1	
5	4D9-24763-00	PAD, SEAT 2	1	
6	B5C-28396-00-P0	PLATE 1	1	MBL2
7	B5C-2837N-00	GRILL, AIR INTAKE 1	1	
8	90183-05M02	NUT, SPRING	3	
9	2C0-2174X-00	DAMPER	1	
10	90480-13018	GROMMET	1	
11	90387-0611W	COLLAR	1	
12	B5C-2836K-00	PANEL, INNER 1	1	
13	90183-05M02	NUT, SPRING	8	
14	90480-13018	GROMMET	1	
15	90387-0611W	COLLAR	1	
16	5PW-2177L-01	PLATE, SPRING	3	
17	90480-13398	GROMMET	1	
18	90269-07076	RIVET	1	
19	90111-05007	BOLT,HEX. SOCKET BUTTON	1	
20	90111-05026	BOLT,HEX. SOCKET BUTTON	2	
21	B5C-28229-00-P1	COVER 2	1	UR FOR BNS4
	B5C-28229-00-P3	COVER 2	1	UR FOR MDPBM1
22	13S-28415-00	DAMPER 1	1	
23	5B6-23445-00	DAMPER	1	
24	4D9-24763-00	PAD, SEAT 2	1	
25	B5C-28397-00-P0	PLATE 2	1	MBL2

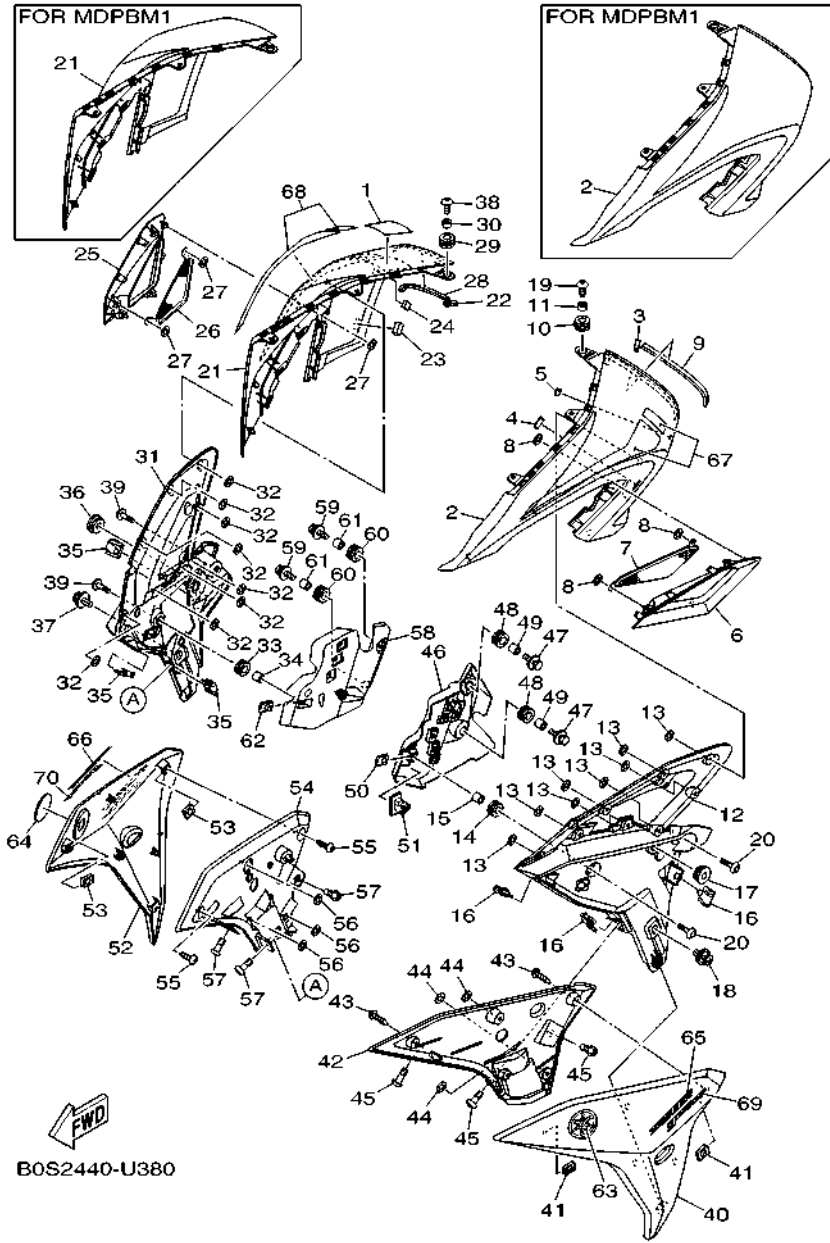

FIG. 38 COWLING

REF. NO.	PART NO.	DESCRIPTION	BOS2	REMARKS
26	B5C-2837R-00	GRILL, AIR INTAKE 2	1	
27	90183-05M02	NUT, SPRING	3	
28	2C0-2174X-00	DAMPER	1	
29	90480-13018	GROMMET	1	
30	90387-0611W	COLLAR	1	
31	B5C-2836L-00	PANEL, INNER 2	1	
32	90183-05M02	NUT, SPRING	8	
33	90480-13018	GROMMET	1	
34	90387-0611W	COLLAR	1	
35	5PW-2177L-01	PLATE, SPRING	3	
36	90480-13398	GROMMET	1	
37	90269-07076	RIVET	1	
38	90111-05007	BOLT,HEX. SOCKET BUTTON	1	
39	90111-05026	BOLT,HEX. SOCKET BUTTON	2	
40	B5C-2835U-00-P3	PANEL 1	1	DRMK FOR BNS4
	B5C-2835U-00-P0	PANEL 1	1	MBL2 FOR MDPBM1
41	90183-05042	NUT, SPRING	2	
42	B5C-2837L-00	PANEL, CONSOLE 1	1	
43	90167-05079	SCREW, TAPPING	2	
44	90183-05M02	NUT, SPRING	3	
45	14B-28386-00	HEAD	3	
46	2PP-2836H-00	BRACKET 5	1	
47	90119-06267	BOLT, WITH WASHER	2	
48	90480-14003	GROMMET	2	
49	90387-06057	COLLAR	2	
50	90183-05076	NUT, SPRING	1	
51	90464-25160	CLAMP	1	

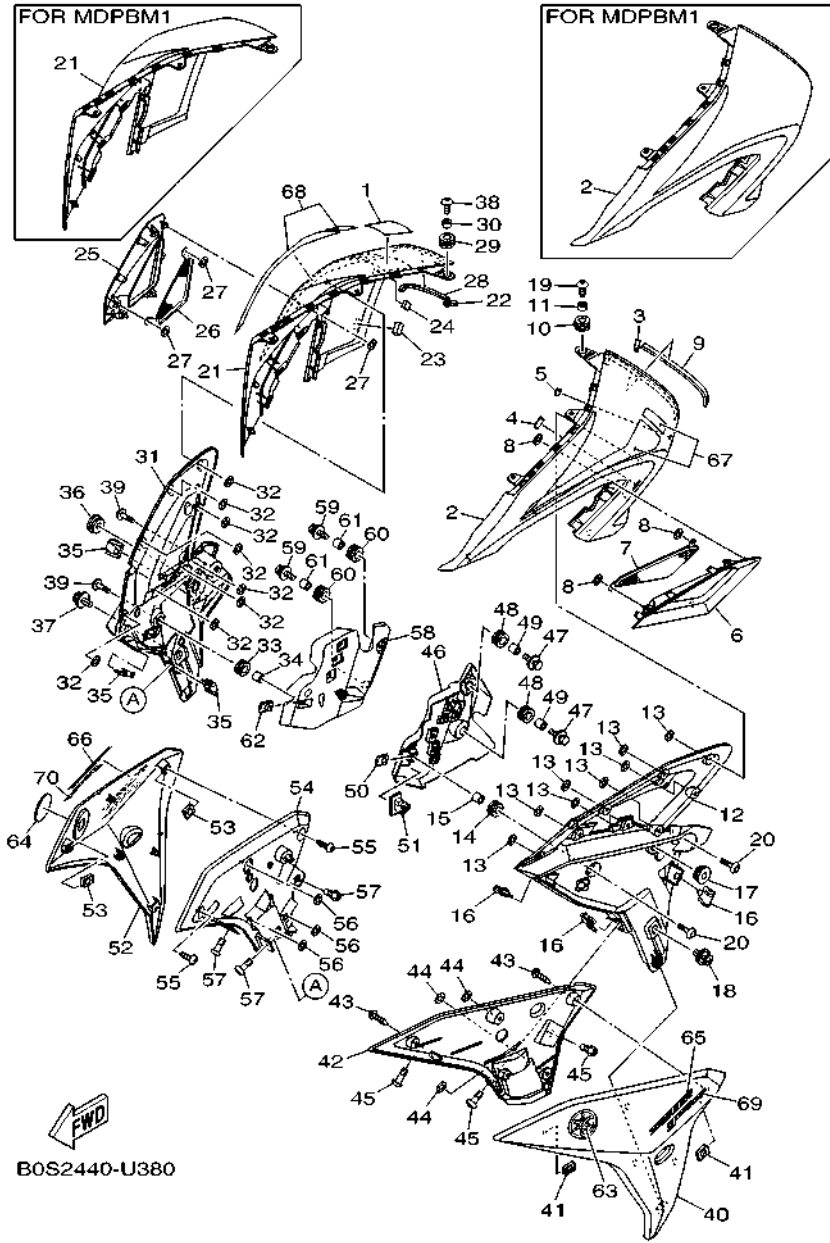
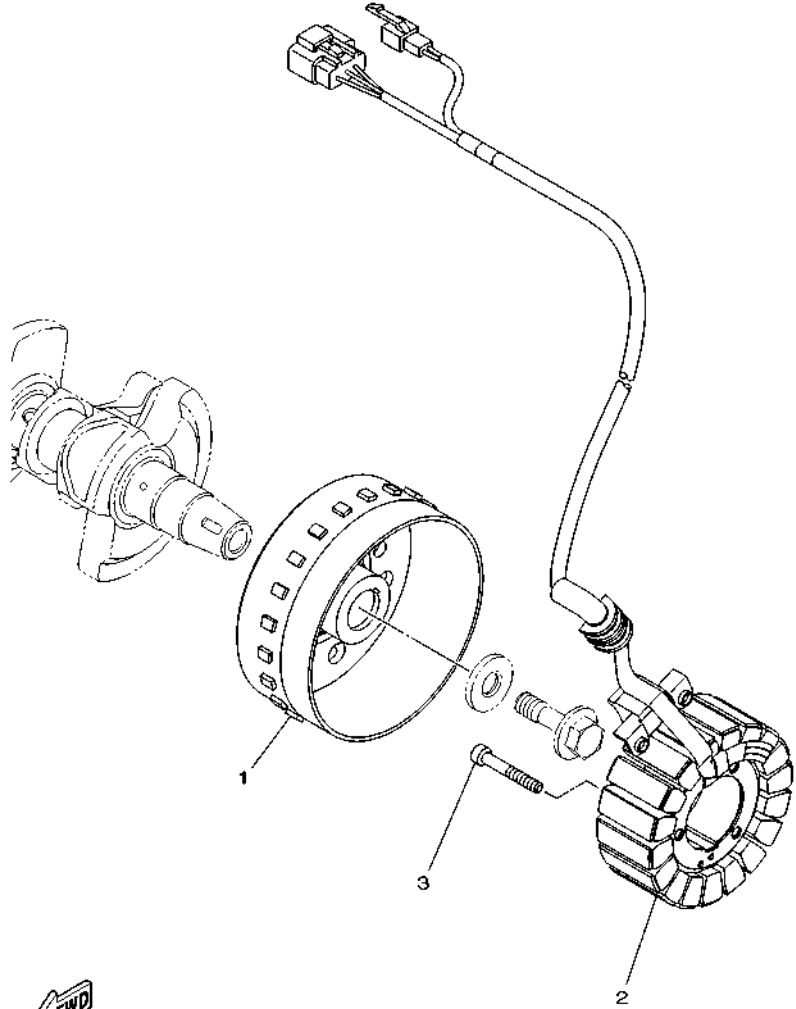

FIG. 38 COWLING

REF. NO.	PART NO.	DESCRIPTION	BOS2	REMARKS
52	B5C-2835V-00-P3	PANEL 2	1	DRMK FOR BNS4
	B5C-2835V-00-P0	PANEL 2	1	MBL2 FOR MDPBM1
53	90183-05042	NUT, SPRING	2	
54	B5C-2837M-00	PANEL, CONSOLE 2	1	
55	90167-05079	SCREW, TAPPING	2	
56	90183-05M02	NUT, SPRING	3	
57	14B-28386-00	HEAD	3	
58	2PP-2836J-00	BRACKET 6	1	
59	90119-06267	BOLT, WITH WASHER	2	
60	90480-14003	GROMMET	2	
61	90387-06057	COLLAR	2	
62	90183-05076	NUT, SPRING	1	
63	1RC-2413B-00	EMBLEM	1	
64	1RC-2413B-00	EMBLEM	1	
65	2PP-2839B-11	EMBLEM 3D	1	
66	2PP-2839B-11	EMBLEM 3D	1	
67	B5C-28391-20	GRAPHIC 1	1	FOR BNS4
68	B5C-28392-20	GRAPHIC 2	1	FOR BNS4
69	B1J-28315-30	EMBLEM	1	UR FOR BNS4
	B1J-28315-10	EMBLEM	1	UR FOR MDPBM1
70	B1J-28315-30	EMBLEM	1	UR FOR BNS4
	B1J-28315-10	EMBLEM	1	UR FOR MDPBM1

FIG. 39 GENERATOR



1RC1300-N370

REF. NO.	PART NO.	DESCRIPTION	BOS2					REMARKS
1	1RC-81450-00	ROTOR ASSY	1					
2	1RC-81410-00	STATOR ASSY	1					
3	90110-06223	BOLT, HEXAGON SOCKET HEAD	3					

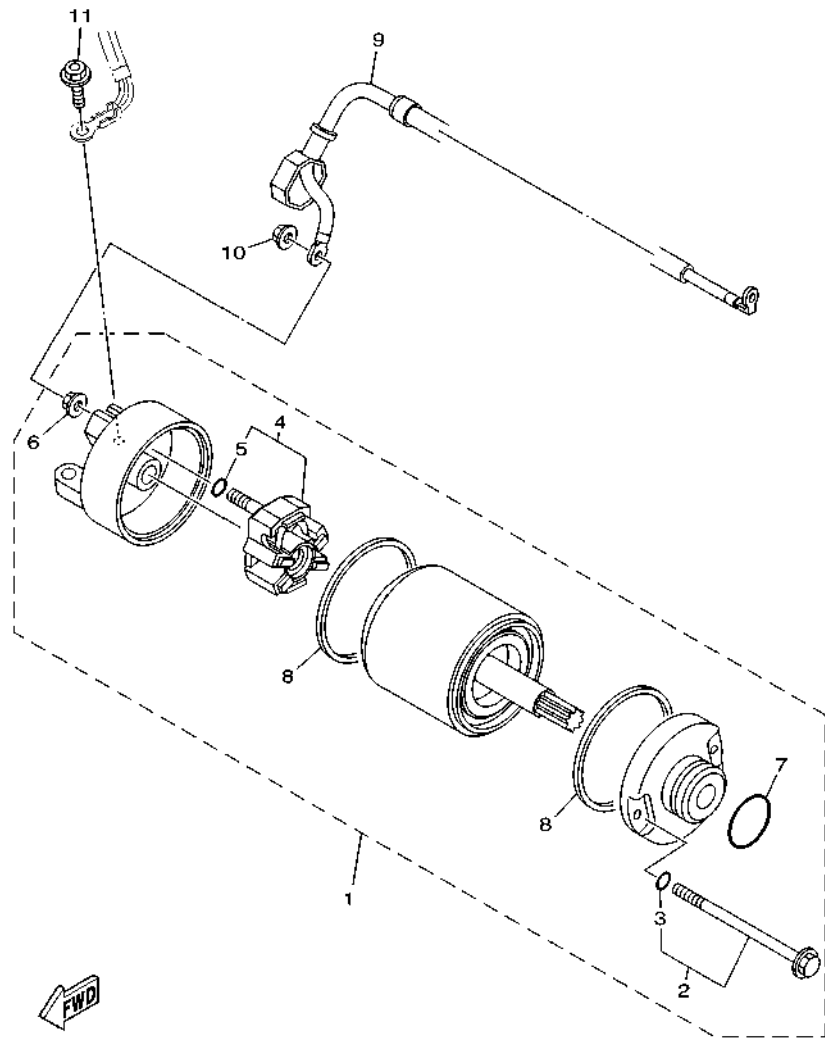

1RC1300-N380

FIG. 40 STARTING MOTOR

REF. NO.	PART NO.	DESCRIPTION	BOS2	REMARKS
1	1RC-81890-00	MOTOR ASSY	1	
2	28P-81826-00	.BOLT	2	
3	3TB-81847-00	.O-RING	1	
4	4B5-81840-00	.BRUSH HOLDER ASSY	1	
5	3TB-81847-00	.O-RING	1	
6	4XV-8182A-00	.NUT	1	
7	1FK-81847-00	.O-RING	1	
8	11H-81844-00	.GASKET	2	
9	1RC-81815-00	CORD, STARTER MOTOR	1	
10	4XV-8182A-00	NUT	1	
11	90110-06388	BOLT, HEXAGON SOCKET HEAD	2	

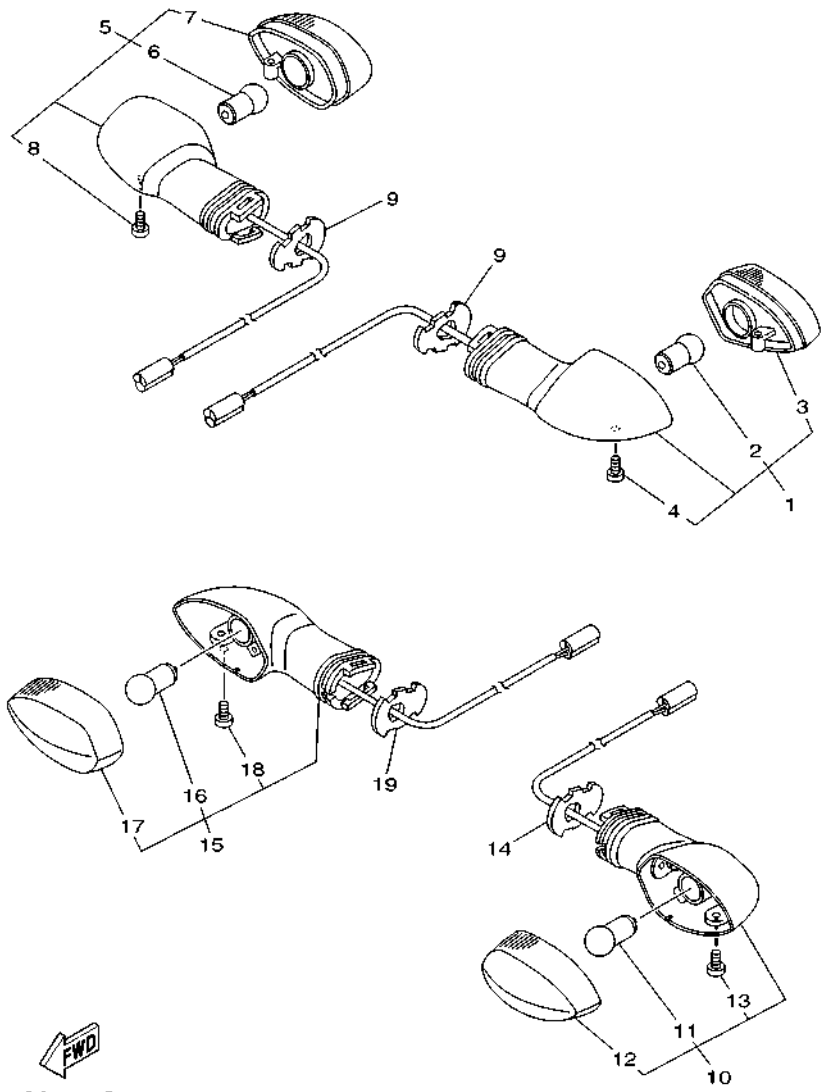
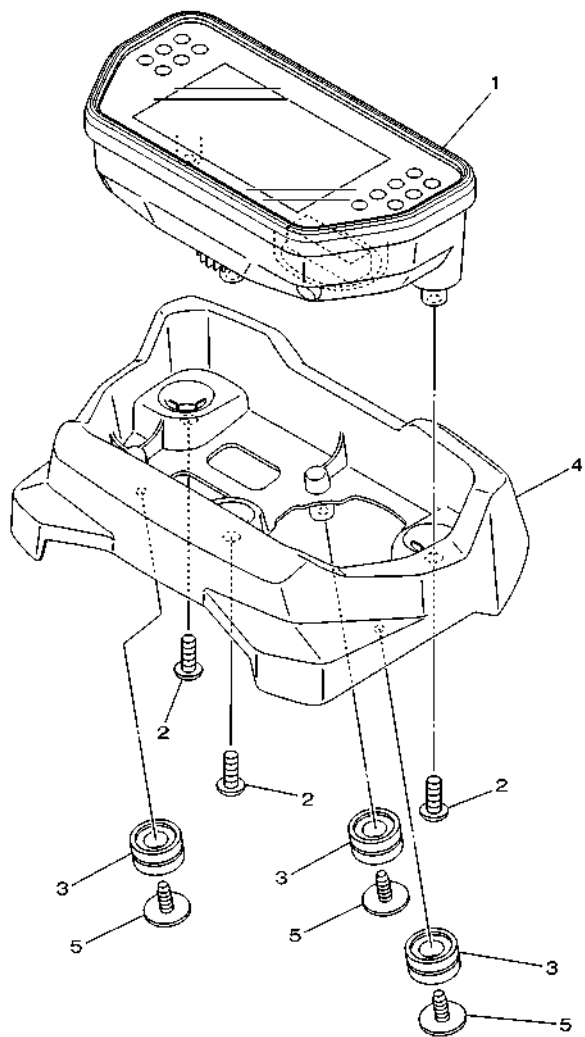

FIG. 41 FLASHER LIGHT

REF. NO.	PART NO.	DESCRIPTION	BOS2	REMARKS
1	2PP-83330-00	REAR FLASHER LIGHT ASSY 1	1	
2	1KB-83311-00	.BULB, FLASHER (12V-10W)	1	
3	1KB-8334A-00	.LENS COMP 2	1	
4	3D9-H3333-10	.SCREW, LENS FITTING	1	
5	2PP-83340-00	REAR FLASHER LIGHT ASSY 2	1	
6	1KB-83311-00	.BULB, FLASHER (12V-10W)	1	
7	1KB-8333A-00	.LENS COMP 1	1	
8	3D9-H3333-10	.SCREW, LENS FITTING	1	
9	3D7-83318-10	STAY, FLASHER 1	2	
10	2PP-83310-00	FRONT FLASHER LIGHT ASSY 1	1	
11	1KB-83311-00	.BULB, FLASHER (12V-10W)	1	
12	1KB-8333A-00	.LENS COMP 1	1	
13	3D9-H3333-10	.SCREW, LENS FITTING	1	
14	3D7-83318-10	STAY, FLASHER 1	1	
15	2PP-83320-00	FRONT FLASHER LIGHT ASSY 2	1	
16	1KB-83311-00	.BULB, FLASHER (12V-10W)	1	
17	1KB-8334A-00	.LENS COMP 2	1	
18	3D9-H3333-10	.SCREW, LENS FITTING	1	
19	3D7-83318-10	STAY, FLASHER 1	1	

FIG. 42 METER

REF. NO.	PART NO.	DESCRIPTION	BOS2					REMARKS
1	B1J-83500-00	METER ASSY	1					
2	97707-50016	SCREW, TRUSS HEAD TAPPING	3					
3	3C3-83513-00	DAMPER	3					
4	B1J-83559-00	COVER, METER	1					
5	90164-05014	SCREW, TAPPING	3					



B1J1300-T420

FIG. 43 HEADLIGHT

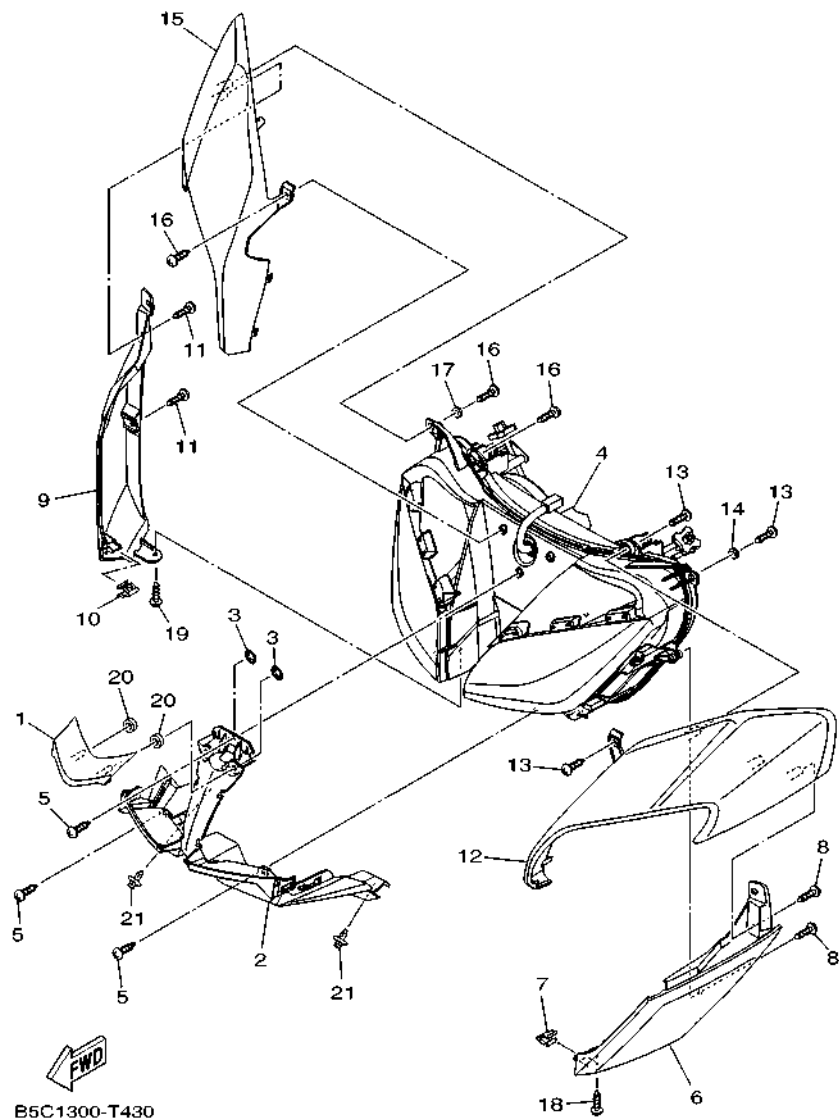

B5C1300-T430

REF. NO.	PART NO.	DESCRIPTION	BOS2			REMARKS
1	B5C-84369-00-P0	COVER 1	1			MBL2
2	B5C-84144-00	COVER, HEADLIGHT	1			
3	90183-05M02	NUT, SPRING	2			
4	B5C-84300-00	HEADLIGHT ASSY	1			
5	97707-40514	SCREW, TAPPING	3			
6	B5C-84544-00	COVER	1			
7	90468-040A0	CLIP	1			
8	97707-40514	SCREW, TAPPING	2			
9	B5C-84797-00	COVER	1			
10	90468-040A0	CLIP	1			
11	97707-40514	SCREW, TAPPING	2			
12	B5C-84196-00-P3	COVER, SOCKET	1			UR FOR BNS4
	B5C-84196-00-P2	COVER, SOCKET	1			UR FOR MDPBM1
13	97707-40514	SCREW, TAPPING	3			
14	90201-05040	WASHER, PLATE	1			
15	B5C-85537-00-P3	COVER	1			UR FOR BNS4
	B5C-85537-00-P2	COVER	1			UR FOR MDPBM1
16	97707-40514	SCREW, TAPPING	3			
17	90201-05040	WASHER, PLATE	1			
18	97707-40514	SCREW, TAPPING	1			
19	97707-40514	SCREW, TAPPING	1			
20	B5C-28307-00	SEAL	2			
21	90269-07007	RIVET	2			

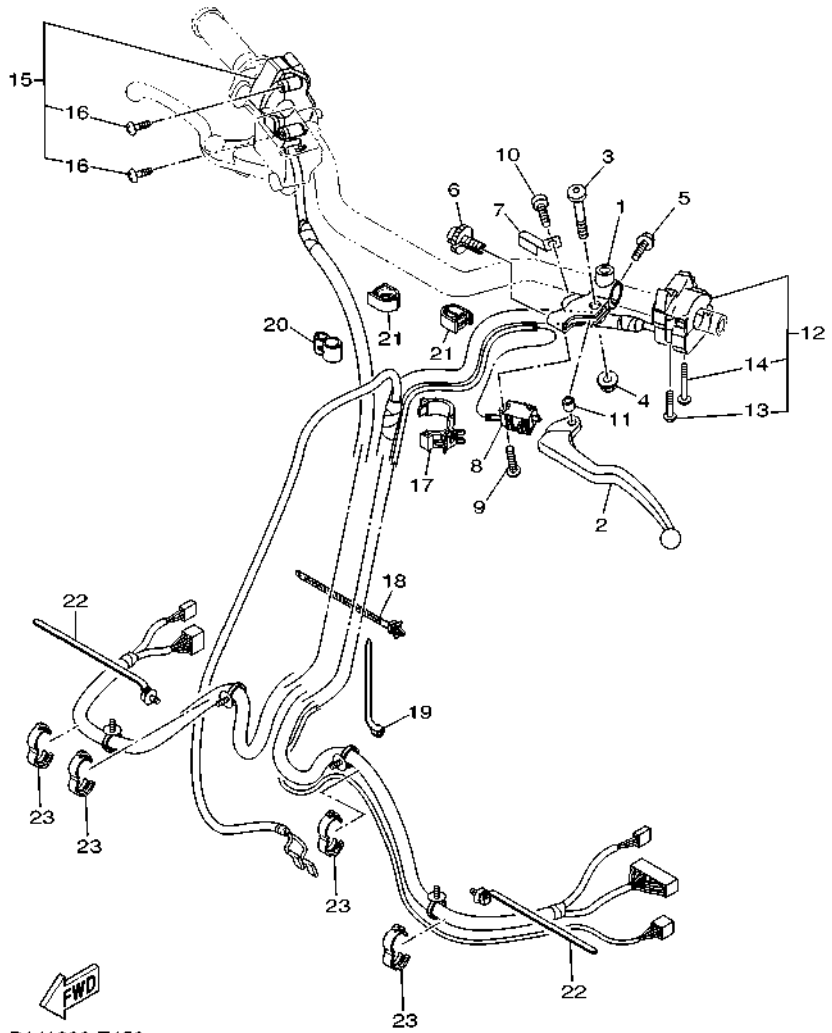

B1J1300-T450

FIG. 45 HANDLE SWITCH & LEVER

REF. NO.	PART NO.	DESCRIPTION	BOS2			REMARKS
1	B67-82911-00	HOLDER, LEVER 1	1			
2	B67-83912-00	LEVER 1	1			
3	2C0-83945-00	BOLT, LEVER	1			
4	95607-06200	NUT, SELF U-FLANGE	1			
5	95027-06020	BOLT, FLANGE	1			
6	5LV-83951-00	BOLT, CABLE ADJUSTING	1			
7	4XV-83929-00	PLATE, SPRING	1			
8	B1J-82917-00	SWITCH	1			
9	90159-04011	SCREW, WITH WASHER	1			
10	98507-04010	SCREW, PAN HEAD	1			
11	5JJ-83913-00	COLLAR, LEVER 1	1			
12	B1J-83954-00	SWITCH, HANDLE 7	1			
13	98507-04020	.SCREW, PAN HEAD	1			
14	98507-04035	.SCREW, PAN HEAD	1			
15	B1J-83963-00	SWITCH, HANDLE 3	1			
16	98507-05020	.SCREW, PAN HEAD	2			
17	90464-25217	CLAMP	1			
18	90464-12036	CLAMP	1			
19	90464-13073	CLAMP	1			(125.0x7.0)
20	90464-10233	CLAMP	1			
21	90464-18004	CLAMP	2			
22	90464-30010	CLAMP	2			
23	90464-14010	CLAMP	4			

FIG. 46 ELECTRICAL 1

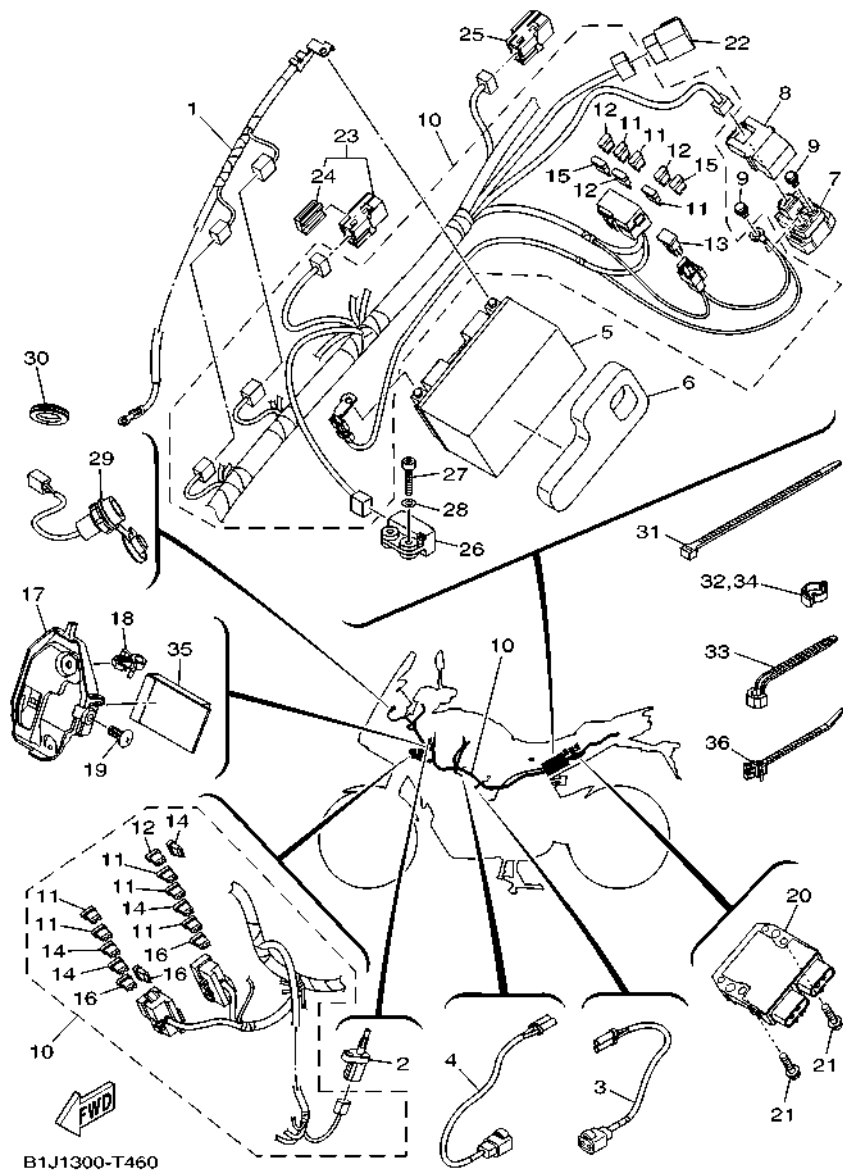

B1J1300-T460

REF. NO.	PART NO.	DESCRIPTION	BOS2				REMARKS
1	BS2-82116-00	WIRE, MINUS LEAD	1				
2	5YU-85886-00	SENSOR, AIR TEMPERATURE	1				
3	1RC-82309-01	WIRE, SUB LEAD	1				
4	1RC-82509-00	WIRE, SUB LEAD	1				
5	5VY-82100-00	BATTERY ASSY (YUASA YTZ10S)	1				
6	1RC-8246K-00	SPACER	1				
7	2PP-81940-00	STARTER RELAY ASSY	1				
8	5SL-82119-30	COVER, LEAD WIRE	1				
9	95022-06008	BOLT, FLANGE	2				
10	B1J-82590-00	WIRE HARNESS ASSY	1				
11	5JJ-82151-00	.FUSE (7.5A-BL)	8				
12	5JJ-82151-10	.FUSE (15A-BL)	4				
13	5JW-82151-10	.FUSE (50A)	1				
14	5JJ-82151-80	.FUSE (2A-BL)	4				
15	5JJ-82151-60	.FUSE (30A-BL)	2				
16	5JJ-82151-A0	.FUSE (1A-BL)	3				
17	1RC-82599-00	COVER, CONNECTOR	1				
18	90464-15157	CLAMP	1				
19	90269-07015	RIVET	1				
20	1D7-81960-10	RECTIFIER & REGULATOR ASSY	1				
21	95022-06025	BOLT, FLANGE	2				
22	5VK-81950-40	RELAY ASSY (5VK-40)	1				
23	1ST-81950-00	RELAY ASSY (1ST-00)	1				
24	5JJ-81952-00	.HOLDER, RELAY	1				
25	5JJ-81950-10	RELAY ASSY (G8HN-1C4T-DJ-Y51)	1				
26	5PS-82576-01	SENSOR, LEAN ANGLE	1				
27	91312-04020	BOLT, HEXAGON SOCKET HEAD	2				

FIG. 46 ELECTRICAL 1

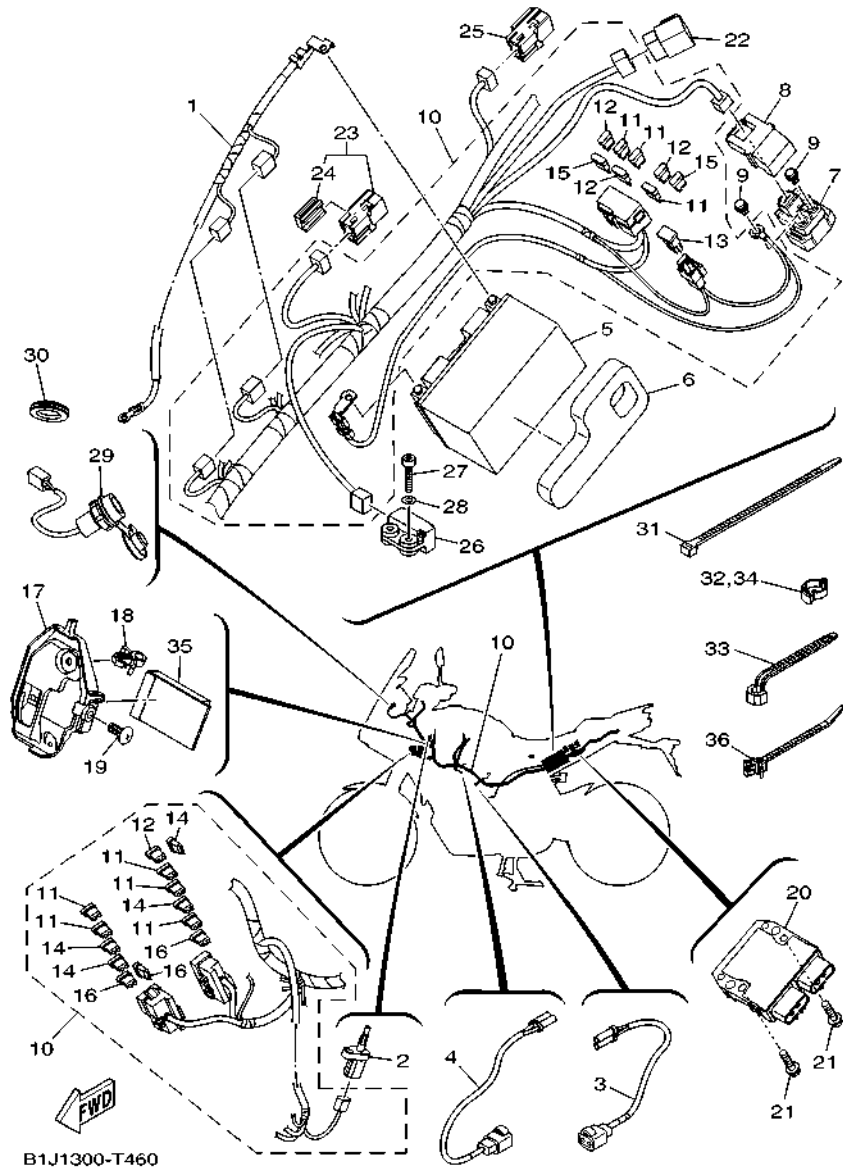

REF. NO.	PART NO.	DESCRIPTION	BOS2	REMARKS
28	90201-04030	WASHER, PLATE	2	
29	2SC-8254B-00	TERMINAL COMP.	1	
30	2BS-24747-00	DAMPER, SEAT	1	
31	3MA-82591-00	BAND	1	
32	90464-14010	CLAMP	1	
33	90464-13073	CLAMP	1	(125.0x7.0)
34	90464-14010	CLAMP	1	
35	1RC-82589-00	PROTECTOR, WIRE HARNESS	1	
36	90464-27002	CLAMP	1	

FIG. 47 ELECTRICAL 2

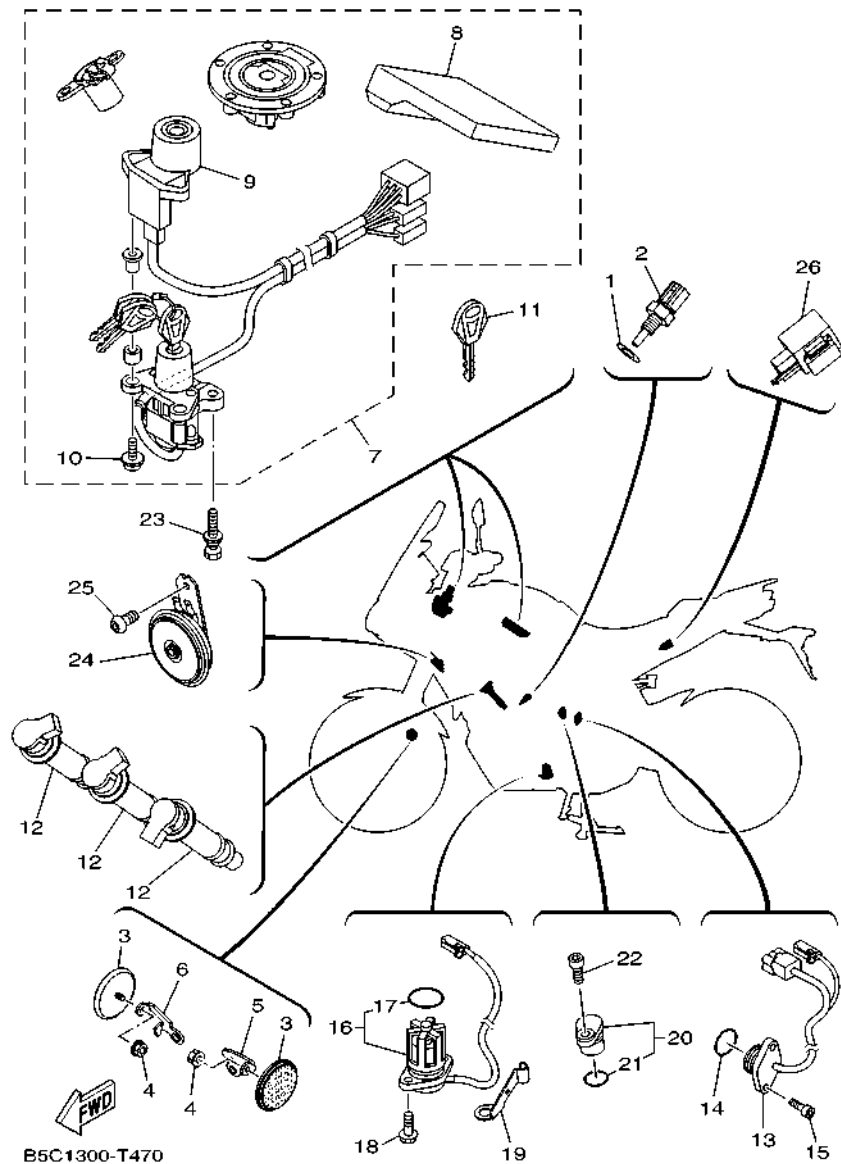

REF. NO.	PART NO.	DESCRIPTION	BOS2				REMARKS
1	90430-10004	GASKET	1				
2	4P9-83591-00	THERMO UNIT	1				
3	4AG-85111-00	REFLECTOR, FRONT 1	2				
4	95702-06500	NUT, FLANGE	2				
5	B90-85112-00	BRACKET, REFLECTOR 1	1				
6	B90-85122-00	BRACKET, REFLECTOR 2	1				
7	B1J-W8250-00	MAIN SW. IMMOBILIZER KIT	1				
8	B1J-8591A-00	.ENGINE CONTROL UNIT ASSY	1				
9	1RC-8255P-00	.IMMOBILIZER. UNIT COMP.	1				
10	5SL-82113-01	.SCREW	2				
11	5SL-82511-08	BLANK KEY	1				AP
12	1RC-82310-00	IGNITION COIL ASSY	3				
13	1RC-82540-00	NEUTRAL SWITCH ASSY	1				
14	93210-21001	O-RING	1				
15	90110-05067	BOLT, HEXAGON SOCKET HEAD	2				
16	5S7-85720-00	OIL LEVEL GAUGE ASSY	1				
17	5VY-8A8E0-00	.O-RING	1				
18	95022-06016	BOLT, FLANGE	2				
19	90465-08053	CLAMP	1				
20	3P6-15399-00	PLUG, BLIND	1				
21	93210-15566	.O-RING	1				
22	90110-06161	BOLT, HEXAGON SOCKET HEAD	1				
23	90109-08196	BOLT	2				
24	BS2-83371-00	HORN	1				
25	92017-06010	BOLT, BUTTON HEAD	1				
26	4GY-83350-00	FLASHER RELAY ASSY	1				

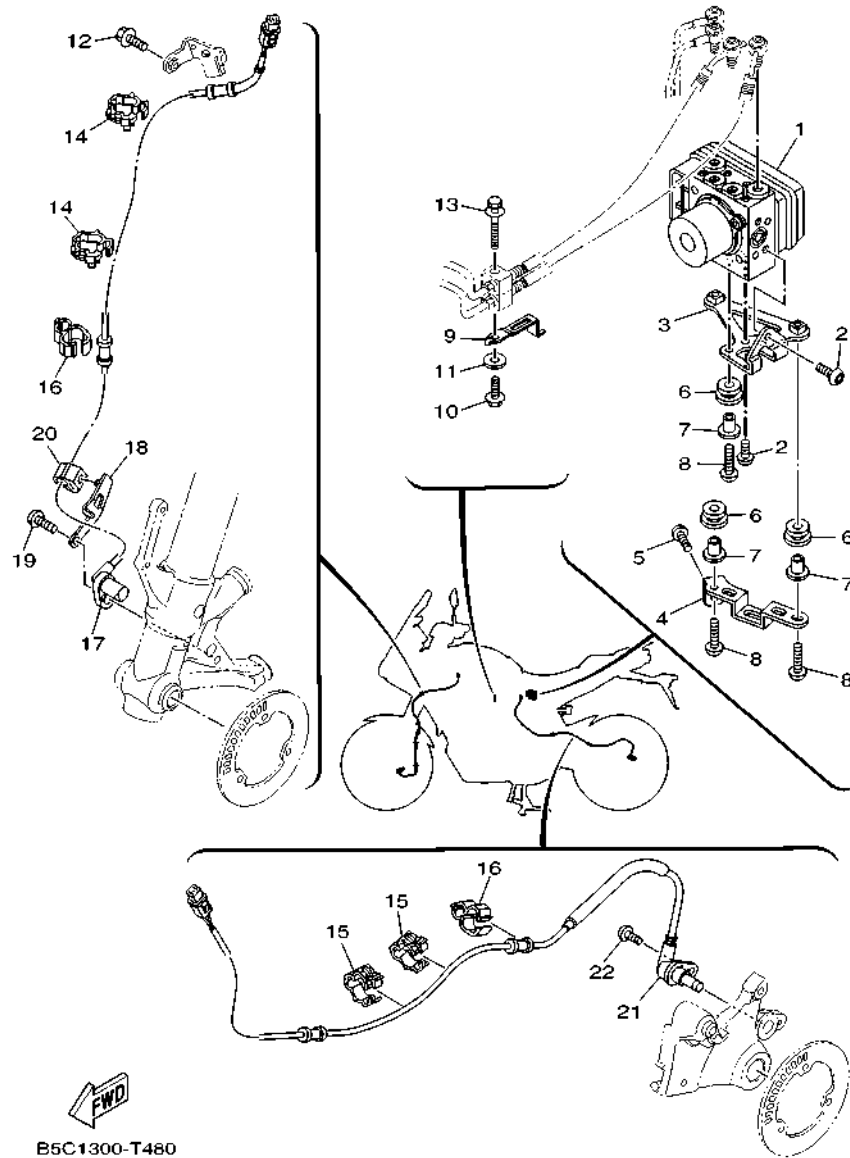

B5C1300-T480

FIG. 48 ELECTRICAL 3

REF. NO.	PART NO.	DESCRIPTION	BOS2				REMARKS
1	B50-85930-09	HYDRAULIC UNIT ASSY	1				
2	92012-06010	BOLT, BUTTON HEAD	2				
3	2DR-85991-00	BRACKET, UNIT	1				
4	2DR-85542-00	BRACKET	1				
5	92012-06010	BOLT, BUTTON HEAD	1				
6	90480-13567	GROMMET	3				
7	90387-06160	COLLAR	3				
8	92012-06020	BOLT, BUTTON HEAD	3				
9	BS2-85132-00	BRACKET, REFLECTOR 1	1				
10	95022-06025	BOLT, FLANGE	1				
11	90201-087P8	WASHER, PLATE	1				
12	95827-06016	BOLT, FLANGE	1				
13	90119-06M55	BOLT, WITH WASHER	1				
14	90464-12013	CLAMP	2				
15	90464-14003	CLAMP	2				
16	90464-10233	CLAMP	2				
17	BS2-85970-00	WHEEL SENSOR ASSY, FRONT	1				
18	BS2-85542-00	BRACKET	1				
19	92017-06016	BOLT, BUTTON HEAD	1				
20	90464-05188	CLAMP	1				
21	B5C-85980-00	WHEEL SENSOR ASSY, REAR	1				
22	92014-06014	BOLT, BUTTON HEAD	1				

NUMERICAL INDEX

PART NO.	REF. NO.	PART NO.	REF. NO.	PART NO.	REF. NO.	PART NO.	REF. NO.	PART NO.	REF. NO.	PART NO.	REF. NO.
B90-11101-09	1 - 1	1HX-12168-U1	3 - 9	1RC-12588-00	5 - 32	2PP-14708-00	12 - 3	1RC-16181-00	16 - 28	1RC-18531-00	18 - 7
5VY-1111G-00	1 - 11	1HX-12168-W1	3 - 9	1RC-12637-00	6 - 15	2PP-14710-00	12 - 1	5TA-16321-00	16 - 4	20S-18535-00	18 - 8
	1 - 28	1HX-12168-Y1	3 - 9	3D8-12675-00	6 - 3	5VY-14747-00	12 - 7	1TD-16324-00	16 - 7	2C0-18536-00	18 - 9
	1 - 30	1HX-12169-11	3 - 9	5VY-13117-10	7 - 9	5VY-1482K-00	1 - 17	BR9-16324-00	16 - 14	1RC-18540-00	18 - 1
2C0-11133-11	1 - 2	1HX-12169-31	3 - 9	1RC-13300-00	7 - 1	5JW-1482K-01	1 - 16		16 - 15	3D7-18542-00	18 - 3
B90-11165-00	1 - 23	1RC-12169-50	3 - 9	1RC-13355-00	7 - 2	2S3-14840-00	11 - 1	4B1-16325-00	16 - 14	1RC-18562-00	18 - 10
BD5-11167-00	1 - 26	1HX-12169-70	3 - 9	B56-13400-10	8 - 3	1RC-14881-00	11 - 2		16 - 15	B1J-21110-00	20 - 1
1RC-11169-00	1 - 24	1HX-12169-90	3 - 9	1RC-13410-00	7 - 6	1RC-14882-00	11 - 4	5VY-16325-00	16 - 6	2PP-2115J-00	28 - 34
BS2-11181-00	1 - 12	1HX-12169-E0	3 - 9	BD5-13414-00	8 - 6	1RC-14883-00	11 - 6		16 - 14	B1J-2115K-00	35 - 49
1RC-11191-00	1 - 13	1HX-12169-G0	3 - 9	5GH-13440-60	8 - 2	5JW-14889-00	1 - 21		16 - 15	2PP-2117E-00	21 - 13
1RC-11193-01	1 - 15	1HX-12169-J0	3 - 9	BS2-13470-00	8 - 10	5PS-14890-00	1 - 20	B90-16331-00	16 - 5	1RC-2117G-00	20 - 13
214-11198-01	8 - 5	1HX-12169-L0	3 - 9	2HC-13473-00	8 - 11	5SL-14890-00	1 - 18	2CR-16337-00	16 - 11	B5C-21190-00	20 - 2
1RC-11400-00	2 - 1	1HX-12169-N0	3 - 9	1RC-13542-00	9 - 4	5SL-14899-00	1 - 19	1RC-16340-00	16 - 22	B5C-21214-00	20 - 14
2S3-11413-00	2 - 14	1HX-12169-T0	3 - 9	1RC-13544-00	9 - 2	BS2-15100-09	13 - 1	132-16346-00	19 - 2	B5C-21224-00	20 - 15
2S3-11413-10	2 - 14	1RC-12170-00	4 - 1	1RC-13556-00	10 - 6	5EB-15155-00	13 - 2	B90-16350-10	16 - 8	5VX-21289-00	20 - 11
2S3-11413-20	2 - 14	20S-12176-00	4 - 3	8FP-13556-00	10 - 7	23P-15156-00	13 - 9	B90-16352-00	16 - 10	20S-21308-00	28 - 38
2S3-11413-30	2 - 14	1RC-12180-00	4 - 2	1RC-13573-00	10 - 10	1RC-15163-00	17 - 2	4XV-16356-01	16 - 21	1RC-2144G-00	35 - 29
2S3-11413-40	2 - 14	B90-12210-00	4 - 6	1RC-13635-00	10 - 1	36Y-15189-00	13 - 18	B90-16371-10	16 - 3	1RC-21495-00	20 - 6
5VY-11416-00	2 - 5	1WS-12213-00	4 - 9	B1J-13750-00	9 - 1	1RC-15191-00	14 - 26	5VY-16382-10	16 - 31	4C8-21495-00	20 - 10
5VY-11416-10	2 - 5	5SL-12214-00	4 - 8	4C8-13761-00	10 - 8	1RC-15199-00	14 - 15	1TD-16383-00	16 - 12	1RC-21511-00-P0	21 - 1
5VY-11416-20	2 - 5	5EL-12228-00	4 - 7	1RC-13907-00	27 - 22	B90-15316-00	14 - 17	1TD-16384-00	16 - 13	1RC-21511-00-PE	21 - 1
5VY-11416-30	2 - 5	5BE-12241-00	1 - 14	1RC-13930-00	10 - 3	B90-15326-00	14 - 25	1RC-17121-00	17 - 13	2C0-21566-00	23 - 30
5VY-11416-A0	2 - 5	1RC-12250-01	4 - 12	1RC-13938-00	10 - 5	2H7-15361-00	13 - 17	1RC-17131-00	17 - 8	4C8-21568-10	38 - 1
1RC-11500-00	2 - 13	1RC-12251-00	4 - 11	1RC-13971-10	27 - 46	5GJ-15363-10	14 - 27	1RC-17151-00	17 - 5	1RC-21629-01	21 - 18
1RC-11603-00	2 - 7	5VY-12277-00	26 - 14	2C0-14105-00	9 - 15	1RC-15377-00	13 - 24	1RC-17161-00	17 - 10	2PP-2163A-00	21 - 15
1RC-11631-00	2 - 6		26 - 32	5PS-14147-00	10 - 9	1RC-15393-00	10 - 25	1RC-17211-00	17 - 32	2PP-2163E-00	21 - 29
39P-11633-00	2 - 8	1RC-12405-01	6 - 2	1MC-14216-00	9 - 24	3P6-15399-00	47 - 20	2PP-17221-00	17 - 21	2PP-2164F-00	21 - 28
1RC-11650-01	2 - 2	1RC-12410-00	5 - 21	2C0-14216-00	9 - 9	1RC-15411-01	14 - 1	1RC-17231-00	17 - 29	B5C-2164H-00	20 - 16
1RC-11654-00	2 - 3	1RC-12420-00	5 - 1	5FL-14216-00	9 - 14	1RC-15416-00	14 - 29	1RC-17241-00	17 - 26	B5C-2164J-00	20 - 18
1RC-11656-00	2 - 4	1RC-12422-00	5 - 3	8CC-14216-10	9 - 12	BS2-15418-00	13 - 25	1RC-17251-10	17 - 30	B5C-21650-00	23 - 18
1RC-11656-10	2 - 4	5FC-12437-00	6 - 12	3XV-14251-00	9 - 7	1RC-15421-11	14 - 16	2PP-17261-00	17 - 24	2PP-21651-00	21 - 34
1RC-11656-20	2 - 4	5VK-12438-00	5 - 7	8FP-14349-00	9 - 6	1RC-15441-00	13 - 22	1RC-17411-00	17 - 1	B5C-21668-00	21 - 38
1RC-11656-30	2 - 4	1RC-12439-00	5 - 11	8FP-14349-20	9 - 5	BD5-15451-00	14 - 6	1RC-17421-00	17 - 16	2PP-21682-00	21 - 30
1RC-12111-01	3 - 1	1RC-1243A-00	6 - 22	8FP-14349-30	9 - 8	1RC-15456-00	14 - 30	5PS-17460-00	17 - 34	B5C-21711-00-P1	22 - 1
1RC-12113-00	3 - 4	2PP-1244E-00	6 - 5	1RC-14411-00	10 - 12	1RC-15461-00	14 - 20	1RC-18101-01	19 - 8	B5C-21711-00-P3	22 - 1
1RC-12114-00	3 - 5	1RC-12450-00	5 - 2	1RC-14421-30	10 - 13	1RC-15484-00	14 - 13	1RC-18110-00	19 - 17	B5C-2171A-00	22 - 23
1RC-12116-00	3 - 3	1RC-12459-00	5 - 4	1RC-14425-00	10 - 23	BS2-15490-00	14 - 24	1RC-18112-00	19 - 14	B5C-2171Y-00	22 - 4
3D7-12117-00	3 - 6	2PP-12461-00	6 - 1	1RC-14426-00	10 - 24	B90-15492-00	14 - 18	5EB-18113-00	19 - 18	B5C-21721-00-P1	22 - 13
1WG-12118-00	3 - 7	4FL-12462-00	6 - 11	B90-1443J-00	9 - 21	1RC-15512-00	15 - 1		35 - 39	B5C-21721-00-P3	22 - 13
4TE-12119-00	3 - 8	1RC-12467-00	6 - 7	B50-1444J-00	9 - 22	1RC-15515-00	15 - 5	BS2-18115-00	19 - 19	1RC-2172W-00	6 - 37
1RC-12121-00	3 - 2	1RC-12469-00	5 - 23	1RC-14451-00	10 - 14	5EB-15521-00	15 - 2	5LV-18116-00	19 - 22	B5C-2172Y-00	22 - 16
4C8-12153-09	3 - 10	1AA-12535-00	6 - 4	1RC-14452-00	10 - 15	1RC-15590-00	15 - 3	1D7-18127-00	19 - 4	B5C-21731-00	22 - 3
4C8-12153-10	3 - 10	1RC-12564-00	14 - 7	1RC-14453-00	10 - 17	1RC-16150-00	16 - 1	1RC-18140-00	19 - 11	B5C-21741-00	22 - 15
1HX-12168-F0	3 - 9	1RC-12572-00	10 - 4	1RC-14454-00	10 - 19	5VY-16154-00	16 - 2	4XV-18154-00	19 - 23	1RC-21747-00	21 - 16
1HX-12168-H1	3 - 9	1RC-12576-00	5 - 35	1RC-1445C-00	11 - 7	2C0-16164-00	16 - 27	2C0-18175-00	19 - 10	1RC-21748-00	6 - 33
1HX-12168-K1	3 - 9	1RC-12577-00	5 - 18	1RC-14463-00	10 - 18	5VY-16164-00	16 - 26	1RC-18511-00	18 - 4	1RC-21749-00	6 - 40
1HX-12168-M1	3 - 9	BS2-12578-00	5 - 26	B50-14465-00	9 - 19	B90-16173-00	16 - 9	1RC-18512-00	18 - 5	2C0-2174X-00	38 - 9
1HX-12168-R1	3 - 9	BS2-12579-00	5 - 29	4FM-14613-00	12 - 5	1TD-16178-00	16 - 16	1RC-18513-00	18 - 6		38 - 28

NUMERICAL INDEX

PART NO.	REF. NO.	PART NO.	REF. NO.	PART NO.	REF. NO.	PART NO.	REF. NO.	PART NO.	REF. NO.	PART NO.	REF. NO.
5PW-2177L-01	38 - 16	B1J-23170-10	26 - 10	BS2-24321-00	27 - 64	5MT-25398-00	29 - 7	2VN-25854-00	36 - 9	2PP-26335-02	33 - 11
	38 - 35	4FM-23171-40	26 - 9	3D7-24339-00	27 - 11		31 - 11	2VN-25855-00	36 - 10	2PP-27111-00	35 - 61
1RC-21816-00	6 - 31		26 - 27	68V-24376-00	9 - 3	5MT-25398-10	29 - 7	5VS-25855-00	34 - 4	278-27114-00	28 - 11
1RC-21826-00	6 - 28	278-23181-50	26 - 12	1RC-24486-00	27 - 24		31 - 11	4BP-2585F-01	36 - 4	36C-27114-00	35 - 63
1RC-21828-00	6 - 27		26 - 30	1RC-24491-00	27 - 23	5MT-25398-20	29 - 7	34B-25867-10	34 - 11	371-27114-00	28 - 3
1RC-21871-00	6 - 25	B5C-23317-00	25 - 21	39P-24602-10	27 - 19		31 - 11	2DR-25872-00	34 - 14	2PP-27116-00	35 - 64
1RC-21875-00	6 - 26	2PP-23340-00	26 - 38	2PP-24708-00	28 - 7	1RC-25445-00	31 - 16	14B-25894-00	36 - 7	2PP-27116-10	35 - 65
B5C-22110-00	23 - 1	2PP-2334G-00	25 - 19	B5C-2470F-20	28 - 2	4SV-25802-00	30 - 8	B5C-25895-00	36 - 13	2PP-27151-00	35 - 67
20S-22128-00	23 - 6	3LC-23357-00	26 - 16	B5C-2470H-20	28 - 10		30 - 19	5VS-2589F-00	34 - 7	2PP-27152-00	35 - 68
B5C-22131-00	23 - 25		26 - 34	B5C-24710-00	28 - 1	5SL-25802-00	32 - 6	5VS-2589H-00	34 - 6	2PP-27211-00	35 - 24
46X-22141-00	23 - 46	1RC-23377-00	25 - 18	B5C-24710-20	28 - 1	4SV-25802-10	30 - 6	5SL-25914-00	32 - 11	4BP-27222-02	36 - 5
B5C-22151-00	23 - 11	B5C-23389-00	25 - 15	2PP-24723-00	28 - 8		30 - 17	5DH-25916-00	32 - 16	1RC-27311-00	35 - 1
1RC-22159-00	23 - 47	1RC-23393-00	25 - 7	B5C-24741-00	28 - 4	5SL-25803-00	32 - 7	3JD-25917-00	32 - 13	1RC-27321-00	35 - 2
1RC-2217A-00	23 - 31	5VX-23415-00	25 - 2	2BS-24747-00	46 - 30	3GM-25803-10	30 - 7	5SL-25917-00	32 - 8	2PP-27410-00	35 - 12
1RC-2217M-00	23 - 43	26H-23418-01	25 - 5	B5C-2474A-00	28 - 28		30 - 18	13S-25919-00	30 - 11	B5C-2741L-00	35 - 42
30X-2219X-00	23 - 4	1RC-23435-40	25 - 8	B5C-2474W-00	28 - 29	3MA-25803-10	30 - 9		30 - 22	B5C-2742L-00	35 - 52
B1J-22210-00	24 - 1	2PP-23441-10	25 - 10	B5C-24750-00-P0	28 - 9		30 - 20	5SL-25919-00	32 - 10	B5C-27431-00	35 - 41
B5C-22311-00	23 - 13	5B6-23445-00	38 - 4	B5C-24750-20-P0	28 - 9	5SL-25805-00	30 - 10	2DR-25921-50	32 - 12	1RC-27432-00	35 - 32
B1J-22465-00	20 - 24		38 - 23	2PP-2475H-00	28 - 23		30 - 21	4SV-25924-00	30 - 12	5VX-27437-00	35 - 45
1RC-22825-00	6 - 30	3GB-23448-00	23 - 34	2PP-2475J-00	28 - 25	5VX-25806-00	32 - 14		30 - 23		35 - 55
B1J-23102-00	26 - 19	2PP-2344A-10	25 - 11	4D9-24763-00	38 - 5	1WS-25807-00	34 - 2	8CR-25924-00	32 - 15	B5C-27441-00	35 - 51
B1J-23103-00	26 - 1	3FV-23462-00	26 - 39		38 - 24	56P-25808-50	36 - 2	3GM-25925-00	30 - 13	1RC-27442-00	35 - 14
BS2-23110-00	26 - 21	B90-23857-00	33 - 12	3P6-24780-00	28 - 5	BW8-2580A-00	34 - 1		30 - 24	BS2-27443-00	35 - 23
BS2-23111-00	26 - 35	23P-24104-01	27 - 2	4BP-24780-00	28 - 16	1RC-2580T-00	30 - 5	1RC-25926-00	32 - 17	3XV-27461-02	35 - 18
BS2-23111-10	26 - 17	2PP-24105-00	27 - 10	34B-24785-00	28 - 27	2DR-2580U-00	30 - 16	5VS-25975-00	30 - 27	B5C-27498-00	35 - 48
1RC-23118-00	26 - 15	2PP-24110-00-PC	27 - 1	2PP-2478X-01	28 - 12	2DR-2580W-00	32 - 5	B1J-26111-00	33 - 1	B5C-27499-00	35 - 58
	26 - 33	2PP-2411F-00	27 - 8	B5C-24797-00	28 - 13	2DR-2581J-00	36 - 25	1RC-26132-00	6 - 19	B1J-28100-00	28 - 36
BS2-23120-00	26 - 3	2PP-2411G-00	27 - 30	B5C-2479D-00	28 - 18	B5C-2581K-00	36 - 22	23P-26133-00	33 - 15	2H7-28151-00	28 - 39
4KM-23123-01	26 - 42		27 - 37	B5C-2479K-00	28 - 21	1RC-2581T-00	30 - 1		33 - 17	2GV-28152-00	28 - 40
1RC-23125-00	26 - 8		27 - 44	B5C-2479L-00	28 - 14	1J3-25824-00	30 - 14	B5C-26141-00	33 - 21	23P-28164-00	28 - 41
	26 - 26	5PW-2411J-01	27 - 29	2SC-2482H-00	28 - 19	5VS-25824-00	30 - 25	B5C-26142-00	33 - 23	4KG-28186-10	28 - 42
	26 - 2	2PP-2411L-00	27 - 9	2PP-24847-11	25 - 13	8CR-25824-00	32 - 18	B5C-26143-00-P2	33 - 28	B5C-28219-00-P1	38 - 2
1RC-23126-11	26 - 20	B5C-24129-00	27 - 32	2PP-25117-00	29 - 2	306-25825-01	30 - 15	B5C-26143-00-P3	33 - 28	B5C-28219-00-P3	38 - 2
2PP-23141-00	26 - 13	B5C-24139-00	27 - 39	2SC-25168-00-0X	29 - 1		30 - 26	B5C-26145-00-P2	33 - 29	B5C-28229-00-P1	38 - 21
	26 - 31	1RC-2413B-00	38 - 63	2SC-25168-00-98	29 - 1	1UY-25825-51	32 - 19	B5C-26145-00-P3	33 - 29	B5C-28229-00-P3	38 - 21
4EB-23144-00	26 - 4		38 - 64	2DR-2517G-00	30 - 3	5SL-25827-00	32 - 20	2DR-26199-00	21 - 5	B5C-28307-00	43 - 20
	26 - 22	2PP-2413Y-00	27 - 15		32 - 3	5SL-25827-10	32 - 21	B1J-26223-00	33 - 32	B1J-28315-10	38 - 69
4EB-23145-01	26 - 6	B5C-24141-00	27 - 52	1RC-25181-00	29 - 9	5SL-25828-01	32 - 22	B1J-26224-00	33 - 33		38 - 70
	26 - 24	BS2-24141-00	27 - 56	2PP-25317-00	31 - 7	2D1-2582A-00	36 - 3	1RC-2622H-00	21 - 32	B1J-28315-30	38 - 69
36Y-23146-10	26 - 7	2PP-2414H-00	27 - 54	2SC-25338-00-0X	31 - 3	2PP-2582E-00	36 - 29	2D2-2622K-00	33 - 9		38 - 70
	26 - 25	2PP-2414J-00	27 - 55	2SC-25338-00-98	31 - 3	1RC-2582W-00	32 - 1	B5C-26246-00	33 - 4	B5C-28319-00	37 - 6
3XJ-23147-L0	26 - 18	2CR-24170-00	27 - 57	1RC-25364-00	31 - 8	5SL-25838-00	32 - 9	39P-2627E-00	33 - 19	B5C-2831R-00	37 - 4
	26 - 36	B90-24183-00	27 - 58	5JJ-25366-00	31 - 12	56P-2583V-00	36 - 1	B5C-26280-00	33 - 14	B5C-2831T-00	37 - 5
26H-23156-00	26 - 5	B1J-2419F-00	27 - 59	1RC-2537W-00	31 - 19	2SC-2584A-01	34 - 19	2D2-26281-01	33 - 6	2S3-28347-00	27 - 28
	26 - 23	B5C-241B1-00	27 - 47	1RC-25381-00	31 - 24	2DR-2584B-00	34 - 20	2PP-26282-00	33 - 7	B5C-28356-00	37 - 17
509-23158-L0	26 - 11	B90-24313-00	27 - 61	1RC-25383-00	31 - 14	2C0-25852-00	36 - 8	B5C-26290-00	33 - 16	B5C-2835B-00	37 - 11
	26 - 29	1RC-24315-00	27 - 26	3SP-25388-00	31 - 22	5VS-25852-00	34 - 3	B1J-26302-00	33 - 5	B5C-2835U-00-P0	38 - 40
B1J-23170-00	26 - 28	60L-24321-00	9 - 20	1RC-25389-00	31 - 23	20S-25854-00	34 - 5	2C0-26326-00	36 - 12	B5C-2835U-00-P3	38 - 40

NUMERICAL INDEX

PART NO.	REF. NO.	PART NO.	REF. NO.	PART NO.	REF. NO.	PART NO.	REF. NO.	PART NO.	REF. NO.	PART NO.	REF. NO.
B5C-2835V-00-P0	38 - 52	BS2-82116-00	46 - 1	4GY-83350-00	47 - 26	5VY-8A8E0-00	47 - 17	90110-06161	47 - 22	90111-06130	13 - 28
B5C-2835V-00-P3	38 - 52	5SL-82119-30	46 - 8	BS2-83371-00	47 - 24	3D9-H3333-10	41 - 4	90110-06164	8 - 12	90111-06136	27 - 13
B5C-28361-00	37 - 19	B5C-8212B-00	21 - 4	B1J-83500-00	42 - 1		41 - 8	90110-06168	14 - 14	90111-08005	35 - 26
2PP-2836H-00	38 - 46	3TJ-82131-00	28 - 37	3C3-83513-00	37 - 24		41 - 13	90110-06169	8 - 8	90111-08038	36 - 15
2PP-2836J-00	38 - 58	1RC-82137-00	21 - 9		42 - 3		41 - 18	90110-06173	7 - 10	90111-08057	35 - 59
B5C-2836K-00	38 - 12	5JJ-82151-00	46 - 11	B1J-83559-00	42 - 4	2TV-W2470-00	28 - 20	90110-06175	1 - 22	90111-10039	35 - 15
B5C-2836L-00	38 - 31	5JJ-82151-10	46 - 12	4P9-83591-00	47 - 2	B1J-W8250-00	47 - 7	90110-06200	21 - 3	90116-08087	1 - 6
B5C-2836M-00	37 - 26	5JW-82151-10	46 - 13	B67-83912-00	45 - 2	2PP-YK241-00-PB	27 - 1	90110-06223	39 - 3	90116-10048	31 - 17
B5C-2836T-00	37 - 14	5JJ-82151-60	46 - 15	5JJ-83913-00	45 - 11	90101-08013	23 - 21	90110-06233	6 - 32	90119-06200	27 - 7
B5C-2836X-00	37 - 9	5JJ-82151-80	46 - 14	5VS-83922-00	34 - 9	90101-10042	24 - 2		10 - 27	90119-06267	38 - 47
B5C-28373-00	37 - 15	5JJ-82151-A0	46 - 16	4XV-83929-00	45 - 7	90105-06027	1 - 3	90110-06274	5 - 25		38 - 59
B5C-2837L-00	38 - 42	34D-82176-00	20 - 12	2C0-83945-00	45 - 3	90105-06057	28 - 24	90110-06321	14 - 23	90119-06M55	48 - 13
B5C-2837M-00	38 - 54	1RC-82309-01	46 - 3	5LV-83951-00	45 - 6	90105-06066	7 - 4	90110-06388	5 - 16	90119-08179	37 - 21
B5C-2837N-00	38 - 7	1RC-82310-00	47 - 12	B1J-83954-00	45 - 12	90105-06080	6 - 9		10 - 11	90119-09010	13 - 8
B5C-2837R-00	38 - 26	1WS-82380-00	9 - 10	B1J-83963-00	45 - 15	90105-06126	23 - 26		14 - 10	90119-09013	13 - 7
B5C-28381-00	37 - 1	1RC-8246K-00	46 - 6	B1J-83980-00	34 - 12	90105-06192	34 - 24		14 - 22	90119-09017	1 - 7
14B-28386-00	38 - 45	BS2-82470-00	19 - 24	B5C-84144-00	43 - 2		36 - 24		40 - 11	90149-05029	30 - 4
	38 - 57	1RC-82509-00	46 - 4	B5C-84196-00-P2	43 - 12	90105-06202	13 - 14	90110-06389	14 - 11		32 - 4
B5C-28388-00	37 - 13	5SL-82511-08	47 - 11	B5C-84196-00-P3	43 - 12	90105-07006	4 - 4	90110-06394	5 - 15	90149-05037	1 - 25
B5C-28391-20	38 - 67	B1J-82530-01	35 - 28	B5C-84300-00	43 - 4	90105-10174	23 - 50		14 - 12	90149-06033	35 - 50
B5C-28392-20	38 - 68	1RC-82540-00	47 - 13	1TP-84347-00	21 - 25	90105-10188	35 - 3	90110-06395	4 - 10	90149-06082	17 - 15
B5C-28396-00-P0	38 - 6	2SC-8254B-00	46 - 29	B5C-84369-00-P0	43 - 1	90105-10210	23 - 41	90110-06396	5 - 13	90149-06158	14 - 19
B5C-28397-00-P0	38 - 25	1RC-8255P-00	47 - 9	B5C-84544-00	43 - 6		23 - 44		14 - 31		18 - 11
2PP-2839B-11	38 - 65	1RC-82566-50	35 - 7	1WS-84547-00	21 - 24	90105-10252	35 - 40	90110-08099	33 - 26	90149-08030	15 - 4
	38 - 66	5PS-82576-01	46 - 26	2PP-84700-00	44 - 1	90105-10377	35 - 17	90110-08220	20 - 21	90149-08220	20 - 20
13S-28415-00	38 - 3	1RC-82589-00	46 - 35	1WS-84740-00	21 - 23	90105-10391	20 - 7		35 - 60	90149-10060	20 - 3
	38 - 22	B1J-82590-00	46 - 10	B5C-84797-00	43 - 9	90105-10437	20 - 8	90110-10043	20 - 4	90150-05024	37 - 2
1RC-81410-00	39 - 2	3MA-82591-00	46 - 31	4AG-85111-00	47 - 3	90105-10440	30 - 28	90111-05002	27 - 53	90154-03001	33 - 10
1RC-81450-00	39 - 1	1RC-82599-00	46 - 17	B90-85112-00	47 - 5	90105-126A8	2 - 11	90111-05007	27 - 38	90159-04011	45 - 9
1RC-81815-00	40 - 9	B67-82911-00	45 - 1	B90-85122-00	47 - 6	90109-06100	13 - 16		27 - 45	90159-06150	35 - 30
28P-81826-00	40 - 2	B1J-82917-00	45 - 8	3Y6-85130-02	21 - 21	90109-061F7	1 - 8		27 - 48	90160-05012	21 - 31
4XV-8182A-00	40 - 6	B1J-82960-00	33 - 3	2DR-85132-00	34 - 23	90109-06202	21 - 7		38 - 19	90160-05013	10 - 16
	40 - 10	B1J-82963-00	33 - 2	BS2-85132-00	48 - 9	90109-06271	1 - 29		38 - 38	90164-05014	42 - 5
4B5-81840-00	40 - 4	2PP-83310-00	41 - 10	2DR-85142-00	36 - 23	90109-06293	1 - 10	90111-05021	33 - 34	90167-05079	38 - 43
11H-81844-00	40 - 8	1KB-83311-00	41 - 2	B5C-85537-00-P2	43 - 15	90109-064G6	30 - 2	90111-05026	36 - 28		38 - 55
1FK-81847-00	40 - 7		41 - 6	B5C-85537-00-P3	43 - 15	90109-066F0	1 - 27		38 - 20	90170-06228	19 - 20
3TB-81847-00	40 - 3		41 - 11	2DR-85542-00	48 - 4	90109-08045	32 - 2		38 - 39	90170-08010	36 - 6
	40 - 5		41 - 16	BS2-85542-00	48 - 18	90109-08170	12 - 10	90111-05036	35 - 8	90179-05003	37 - 3
1MC-81860-00	9 - 23	3D7-83318-10	41 - 9	5S7-85720-00	47 - 16	90109-08196	47 - 23	90111-05045	22 - 11	90179-05523	6 - 39
1RC-81890-00	40 - 1		41 - 14	1MC-85884-00	9 - 13	90109-08233	35 - 13		22 - 22	90179-08410	12 - 6
2PP-81940-00	46 - 7		41 - 19	13S-85885-00	9 - 11		35 - 22	90111-06029	21 - 14	90179-10024	20 - 9
1ST-81950-00	46 - 23	2PP-83320-00	41 - 15	5YU-85886-00	46 - 2	90109-087F1	28 - 31		23 - 27	90179-20011	16 - 19
5JJ-81950-10	46 - 25	2PP-83330-00	41 - 1	B1J-8591A-00	47 - 8	90109-10019	23 - 36		37 - 16	90179-22018	17 - 36
5VK-81950-40	46 - 22	1KB-8333A-00	41 - 7	59C-8592A-00	12 - 2	90109-10029	35 - 62	90111-06053	28 - 15	90179-25004	25 - 3
5JJ-81952-00	46 - 24		41 - 12	B50-85930-09	48 - 1	90110-05028	27 - 25	90111-06060	12 - 4	90183-05042	22 - 2
1D7-81960-10	46 - 20	2PP-83340-00	41 - 5	BS2-85970-00	48 - 17	90110-05067	47 - 15	90111-06065	28 - 26		22 - 14
5VY-82100-00	46 - 5	1KB-8334A-00	41 - 3	B5C-85980-00	48 - 21	90110-05112	27 - 20	90111-06089	21 - 20		38 - 41
5SL-82113-01	47 - 10		41 - 17	2DR-85991-00	48 - 3	90110-06108	13 - 23	90111-06103	20 - 25		38 - 53

NUMERICAL INDEX

PART NO.	REF. NO.	PART NO.	REF. NO.	PART NO.	REF. NO.	PART NO.	REF. NO.	PART NO.	REF. NO.	PART NO.	REF. NO.
90183-05076	22 - 6	90208-20001	16 - 18	90387-0611W	38 - 15	90430-10005	34 - 17	90465-08053	47 - 19	90480-13398	38 - 17
	33 - 25	90208-22002	17 - 35		38 - 30		34 - 22	90465-10098	33 - 36		38 - 36
	38 - 50	90209-21332	17 - 6		38 - 34		34 - 28	90467-08075	6 - 29	90480-13567	48 - 6
	38 - 62	90209-21351	17 - 12	90387-06136	27 - 12		36 - 27		6 - 35	90480-14003	38 - 48
90183-05M02	22 - 5	90209-22352	17 - 11	90387-06153	21 - 2	90445-19003	35 - 66	90467-09006	9 - 25		38 - 60
	22 - 8	90209-28008	17 - 22	90387-06158	6 - 18	90445-197J2	35 - 6		27 - 27	90480-15363	6 - 17
	22 - 17	90214-28002	17 - 28	90387-06160	48 - 7	90450-32003	5 - 33		27 - 62	90480-18008	27 - 3
	22 - 19	90214-29002	17 - 27	90387-06205	10 - 21		5 - 36	90467-09026	27 - 63	90501-06022	18 - 2
	38 - 8	90240-08005	36 - 16	90387-06210	23 - 29	90450-38040	5 - 19	90467-09103	9 - 18	90501-12743	35 - 43
	38 - 13	90269-07007	21 - 8	90387-06266	27 - 4		5 - 34	90467-10039	6 - 23		35 - 53
	38 - 27		21 - 17	90387-06285	6 - 38	90450-53007	10 - 20		6 - 24	90506-18021	19 - 1
	38 - 32		21 - 37	90387-06286	13 - 26	90450-56009	10 - 2	90467-10041	27 - 65	90506-20032	35 - 5
	38 - 44		22 - 9	90387-06288	21 - 11	90461-10008	25 - 16	90467-100A1	9 - 17	90506-23008	35 - 31
	38 - 56		22 - 20	90387-062X0	23 - 14	90464-05003	33 - 20	90467-120A3	36 - 14	90508-18051	16 - 23
	43 - 3		23 - 12	90387-06302	21 - 36	90464-05188	48 - 20	90467-14015	10 - 28	90508-20572	35 - 21
90183-06069	21 - 6		23 - 17	90387-06322	19 - 26	90464-07M20	33 - 18	90467-15001	10 - 26	90508-32141	19 - 9
90185-08089	35 - 25		27 - 51	90387-06341	35 - 35	90464-07M40	6 - 36	90467-17003	11 - 8	90520-01001	33 - 22
90185-18009	31 - 25		37 - 27	90387-06372	21 - 19	90464-09026	37 - 25	90467-17089	11 - 3		33 - 24
90201-04030	46 - 28		43 - 21	90387-065G0	37 - 23	90464-09M31	27 - 66		11 - 5	91312-04020	46 - 27
90201-05040	43 - 14	90269-07015	46 - 19	90387-07717	6 - 10	90464-10233	45 - 20	90467-200A0	5 - 28	91312-05010	27 - 21
	43 - 17	90269-07076	21 - 35	90387-08021	12 - 8		48 - 16		5 - 31	91312-06020	19 - 15
90201-06033	6 - 21		22 - 10	90387-08077	20 - 22	90464-12013	34 - 25	90467-21068	5 - 27	91312-06025	8 - 7
90201-06072	27 - 5		22 - 21	90387-08102	35 - 37		48 - 14	90467-22002	5 - 30	91312-06030	6 - 20
90201-08048	35 - 38		38 - 18	90387-08114	33 - 27	90464-12036	45 - 18	90467-310A0	5 - 20	91312-06035	7 - 5
90201-08066	36 - 17		38 - 37	90387-10050	35 - 9	90464-13073	45 - 19		5 - 37	91314-08030	25 - 9
90201-08103	35 - 27	90280-05029	2 - 10	90387-10106	23 - 49		46 - 33	90468-040A0	43 - 7		25 - 12
90201-087G2	12 - 9	90338-06007	37 - 18	90387-102R4	23 - 7	90464-13227	19 - 29		43 - 10		26 - 41
90201-087P8	20 - 23	90338-07010	37 - 10		23 - 40	90464-13249	20 - 26	90480-01558	27 - 31	91314-08035	26 - 37
	48 - 11	90338-07157	6 - 8	90387-127W0	23 - 35	90464-14003	48 - 15	90480-01559	27 - 17	91317-05035	33 - 8
90201-10029	16 - 24	90338-16262	13 - 5	90387-17017	29 - 8	90464-14010	19 - 28	90480-11009	21 - 27	91401-20012	36 - 18
90201-10035	23 - 39	90340-14011	13 - 20	90387-20035	31 - 21		45 - 23	90480-12015	21 - 10	91401-25015	35 - 47
	35 - 10	90340-14132	8 - 4	90387-20036	31 - 20		46 - 32	90480-12314	10 - 22		35 - 57
90201-10075	20 - 5	90340-18002	1 - 4	90387-21003	17 - 9		46 - 34	90480-12607	35 - 36	91402-25015	35 - 20
90201-101J1	24 - 4	90340-36005	14 - 2	90387-25008	17 - 31	90464-15157	35 - 34	90480-13010	7 - 8	91701-08040	35 - 19
90201-12008	2 - 12	90380-16134	23 - 2	90387-25030	17 - 4		46 - 18	90480-13018	13 - 27	91702-08040	35 - 46
90201-12541	5 - 14	90387-05025	33 - 31	90387-28004	17 - 25	90464-16003	36 - 21		27 - 33		35 - 56
90201-12575	19 - 7	90387-05028	36 - 11	90387-30012	17 - 18	90464-18002	23 - 23		27 - 35	91808-16023	1 - 5
90201-127E1	19 - 3	90387-05042	21 - 26	90387-31003	17 - 20		34 - 18		27 - 40	92012-05010	22 - 12
90201-13015	23 - 38	90387-06026	27 - 36	90401-10042	34 - 16	90464-18004	45 - 21		27 - 42	92012-05030	6 - 34
90201-17018	35 - 11		27 - 43	90401-10172	34 - 15	90464-18007	36 - 20		27 - 50	92012-06010	6 - 6
90201-177G4	19 - 12	90387-06057	38 - 49		34 - 21	90464-18246	34 - 26		38 - 10		48 - 2
90201-18021	31 - 26		38 - 61		34 - 27	90464-20023	36 - 19		38 - 14		48 - 5
90201-20008	17 - 37	90387-06066	23 - 15		36 - 26	90464-25160	38 - 51		38 - 29	92012-06012	27 - 60
90201-20030	16 - 17	90387-06075	23 - 19	90401-20011	8 - 1	90464-25217	45 - 17		38 - 33		28 - 22
90201-22018	25 - 6	90387-0611W	27 - 34	90413-06031	9 - 16	90464-27002	46 - 36	90480-13203	6 - 41	92012-06020	19 - 27
90202-07164	23 - 24		27 - 41	90430-06014	5 - 12	90464-30010	45 - 22	90480-13398	20 - 17		21 - 12
90202-26142	25 - 4		27 - 49	90430-08143	14 - 5	90464-30011	19 - 25		20 - 19		48 - 8
90206-17084	35 - 16		38 - 11	90430-10004	47 - 1	90465-06025	8 - 9		27 - 16	92012-06030	35 - 70

NUMERICAL INDEX

PART NO.	REF. NO.	PART NO.	REF. NO.	PART NO.	REF. NO.	PART NO.	REF. NO.	PART NO.	REF. NO.	PART NO.	REF. NO.
92012-06035	27 - 6	93306-20464	17 - 14	95602-10200	23 - 51	99247-00080	21 - 39				
92012-06040	35 - 69		17 - 38		25 - 14	99530-08012	14 - 9				
92014-06014	48 - 22	93306-20480	31 - 4		31 - 18	99530-10014	13 - 4				
92014-06016	23 - 20	93306-205B5	31 - 13	95602-14200	23 - 48	99530-12016	1 - 31				
92017-05012	33 - 30	93306-20663	17 - 17	95607-06200	23 - 28						
92017-05016	37 - 7	93306-30534	17 - 3		45 - 4						
92017-06010	33 - 13	93310-33277	16 - 20	95612-10100	23 - 37						
	37 - 20	93315-21570	16 - 30		35 - 4						
	47 - 25	93315-31758	23 - 8	95617-06100	34 - 8						
92017-06012	25 - 17		23 - 32	95702-06500	28 - 6						
92017-06016	48 - 19	93317-11096	16 - 32		28 - 17						
92017-06020	27 - 18	93317-11295	19 - 16		47 - 4						
92017-08012	14 - 4	93317-22262	23 - 3	95802-06010	35 - 33						
92017-10040	28 - 32	93399-99931	25 - 1	95807-06016	25 - 20						
92907-05200	33 - 35	93399-99932	26 - 40	95807-06025	37 - 22						
92907-05600	6 - 14	93440-25186	17 - 7	95812-06025	27 - 14						
92907-08200	28 - 30	93440-31187	17 - 23	95812-06040	13 - 11						
92907-08600	16 - 33	93440-64199	17 - 19	95812-06050	13 - 12						
92907-10200	28 - 33	93450-18157	2 - 9	95812-06065	13 - 13						
93101-12173	5 - 6	93501-04011	35 - 44	95812-08060	13 - 15						
93102-12106	19 - 5		35 - 54	95822-06012	6 - 16						
93102-15212	16 - 29	93603-16219	5 - 8	95822-06025	5 - 22						
93102-25017	29 - 4	93607-44002	4 - 13	95827-06016	48 - 12						
93102-28022	31 - 5	93610-20189	14 - 21	97002-06016	23 - 16						
93102-40030	17 - 33	93900-00030	29 - 6	97007-05012	6 - 13						
93106-22002	23 - 10		31 - 10	97602-04214	34 - 13						
93106-40013	31 - 15	94112-17130	29 - 5	97707-40514	43 - 5						
93108-35004	23 - 5	94118-17381	31 - 9		43 - 8						
93109-17071	23 - 9	94581-79066	7 - 11		43 - 11						
	23 - 33	94591-57128	4 - 5		43 - 13						
93210-04092	13 - 3	94682-4703R	31 - 2		43 - 16						
93210-07540	13 - 10	94701-00431	1 - 9		43 - 18						
93210-12790	13 - 6	94A40-05118	31 - 1		43 - 19						
93210-14369	13 - 21	95022-06008	46 - 9	97707-50012	22 - 7						
93210-14MF4	37 - 8	95022-06016	47 - 18		22 - 18						
93210-15566	47 - 21	95022-06025	46 - 21	97707-50016	42 - 2						
93210-16325	13 - 19		48 - 10	98507-04010	45 - 10						
93210-19123	14 - 28	95024-06012	28 - 35	98507-04020	45 - 13						
93210-21001	47 - 14	95027-06012	25 - 22	98507-04035	45 - 14						
93210-22001	7 - 7	95027-06020	45 - 5	98507-05020	45 - 16						
93210-28543	14 - 8	95027-06030	34 - 10	99001-07600	16 - 34						
93210-30694	5 - 17	95302-08600	23 - 22	99002-10600	19 - 6						
93210-357A3	14 - 3	95304-06700	19 - 21	99009-09800	37 - 12						
93210-46044	5 - 24	95602-05200	21 - 22	99009-10400	16 - 25						
93210-61750	5 - 10	95602-06200	21 - 33	99009-12400	5 - 9						
93306-00106	5 - 5	95602-10100	24 - 3	99009-15500	7 - 3						
93306-00416	31 - 6	95602-10200	23 - 42	99009-17400	19 - 13						
93306-20352	29 - 3		23 - 45	99244-00080	21 - 39						