

# PARTS CATALOGUE

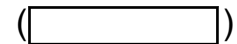
JANUARY 2019

**CZD250-A** ( BU82 ) MALAYSIA *X-MAX*

---



1UBU8-440E1



CZD250-A  
PARTS CATALOGUE  
©2018 by Yamaha Motor Co., Ltd.  
1st edition, November 2018  
All rights reserved.  
Any reprinting or unauthorized use  
without the written permission of  
Yamaha Motor Co., Ltd.  
is expressly prohibited.  
Printed in Japan.

# FOREWORD

This Parts Catalogue is related to the parts for the model(s) on the cover page. When you are ordering replacement parts, please refer to this Parts Catalogue and quote both part numbers and part names correctly.

1. Modifications or additions which have been made after the issue of the Parts Catalogue will be announced in the Parts News.  
It is advisable that you make the necessary corrections to the Parts Catalogue according to the Parts News.

2. Abbreviations

The following abbreviations are used in this Parts Catalogue.

“UR” Use specified parts number.

“UN” Use as many as needed.

“AP” Alternate Parts

“LM” Locally Made (Parts need to be ordered locally)

“F#” Frame No. (Applicable machine No.)

“O/S” Over Size

3. The number of components for assembly

- Parts, which are to be supplied in an assembly, are listed with a dot (.) in front of the part name as shown below.
- The numeral appearing to the right of each component part indicates the quantity of parts for each assembly unit.

PART NO.	DESCRIPTION	Q'TY	REMARKS
2F5-83310-60	FRONT FLASHER LIGHT ASSY	2	
115-83311-60	.BULB (6V-18W)	1	

4. Applicable colours of graphics are represented in the “REMARKS” as shown below.

PART NO.	DESCRIPTION	Q'TY	REMARKS
2N4-24110-00-X5	FUEL TANK COMP.	2	MXR
3J1-24240-10	.GRAPHIC, FUEL TANK	1	FOR MXR

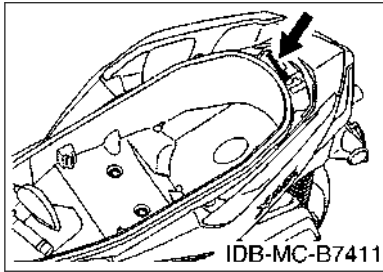
5. Note that the illustrations for reference in finding parts numbers are not to be used for assembling. When assembling, please use the applicable service manual.

6. The asterisk (\*) before a reference number indicates modified items after the first edition.

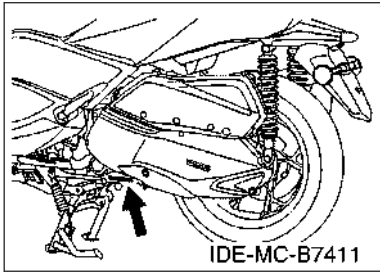
# FOREWORD

7. Applicable Serial No.

Frame Serial No.



Engine Serial No.



8. Applicable Colour Code (The (\*) mark shows Model colour.)

Abbreviation	Colour Name	Colour Code
MBL2	MAT BLACK 2	0582
MBM3(*)	MAT BLUE METALLIC 3	0960
MDRM3(*)	MAT DEEP RED METALLIC 3	1258
YB	YAMAHA BLACK	0033

9. Applicable Starting Serial No.

Frame Serial No.

Serial No.	Name Of Q'ty Column	Model Code

Engine Serial No.

Serial No.	Name Of Q'ty Column	Model Code

# CONTENTS

## ENGINE

CYLINDER.....	1
CRANKSHAFT & PISTON.....	2
VALVE.....	4
CAMSHAFT & CHAIN.....	6
WATER PUMP.....	7
RADIATOR & HOSE.....	8
OIL PUMP.....	10
INTAKE.....	11
EXHAUST.....	13
CRANKCASE.....	14
CRANKCASE COVER 1.....	16
STARTER.....	17
CLUTCH.....	18
TRANSMISSION.....	20

## CHASSIS

FRAME.....	21
FENDER.....	22
SIDE COVER.....	24
REAR ARM & SUSPENSION.....	26
STEERING.....	27
FRONT FORK.....	28
FUEL TANK.....	30
SEAT.....	31
FRONT WHEEL.....	33
FRONT BRAKE CALIPER.....	34
REAR WHEEL.....	35
REAR BRAKE CALIPER.....	36
STEERING HANDLE & CABLE.....	37
FRONT MASTER CYLINDER.....	38
STAND & FOOTREST.....	40
STAND & FOOTREST 2.....	42
LEG SHIELD.....	44
WINDSHIELD.....	47
GENERATOR.....	50
STARTING MOTOR.....	51
FLASHER LIGHT.....	52
METER.....	53
HEADLIGHT.....	54

TAILLIGHT.....	55
HANDLE SWITCH & LEVER.....	56
ELECTRICAL 1.....	57
ELECTRICAL 2.....	59
ELECTRICAL 3.....	60

## INDEX

NUMERICAL INDEX.....	61
----------------------	----

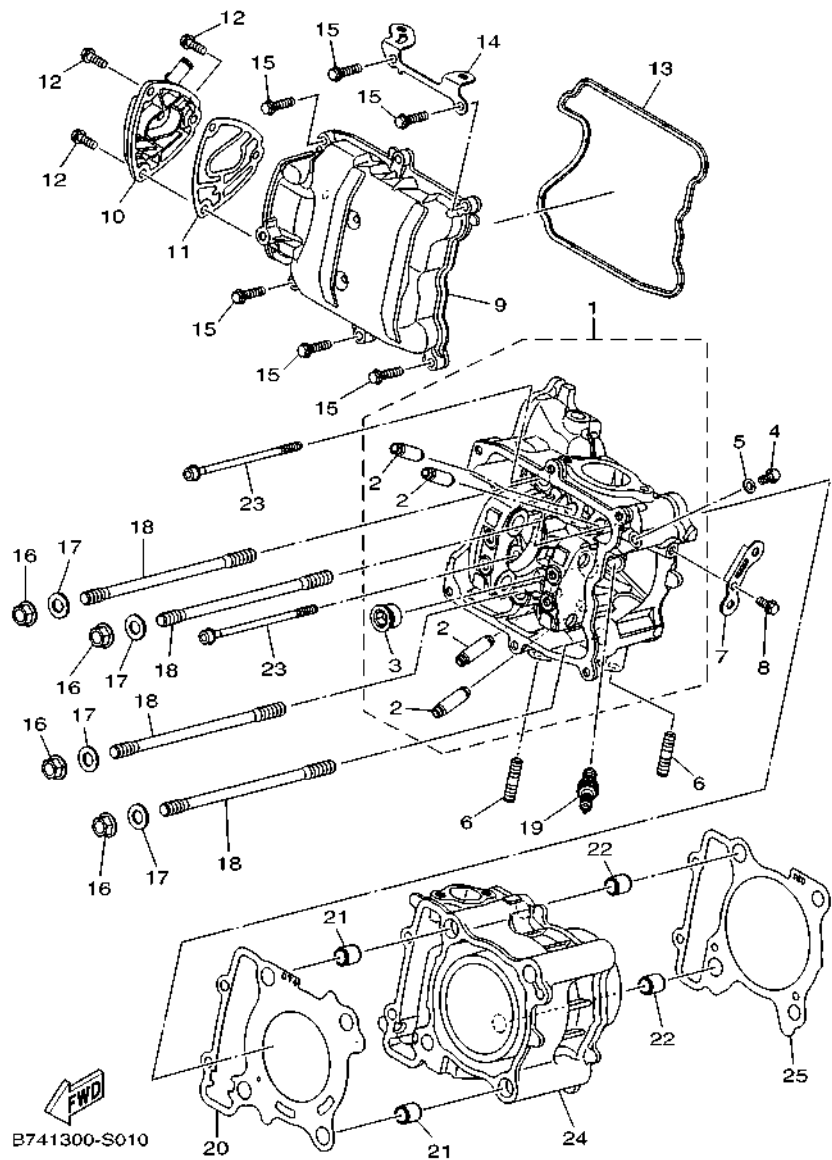
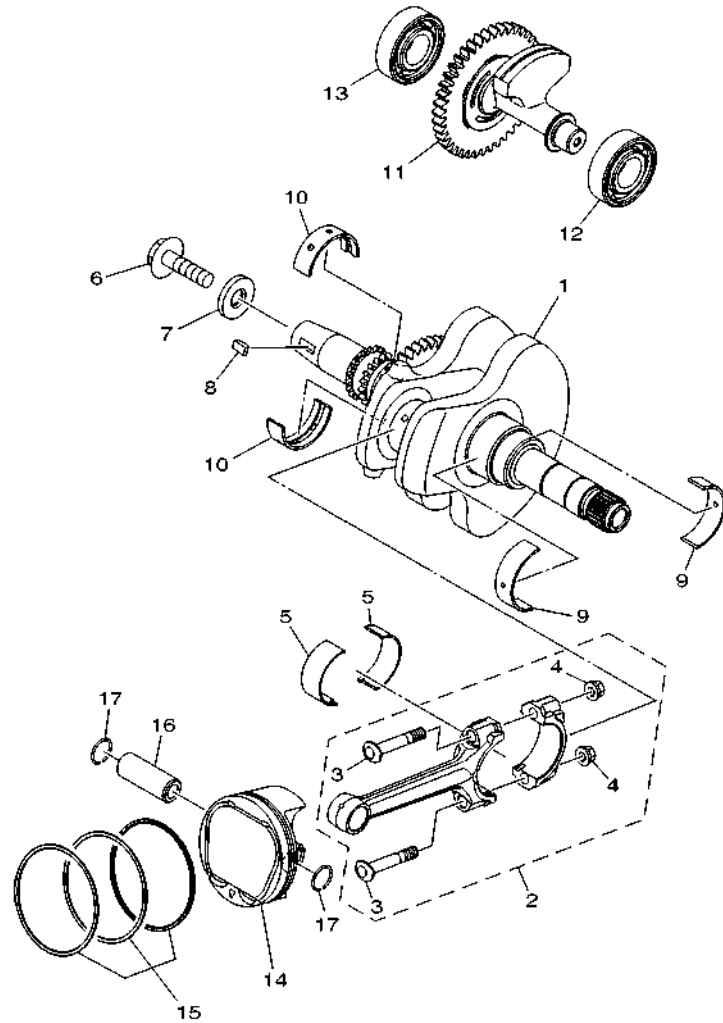


FIG. 1 CYLINDER

REF. NO.	PART NO.	DESCRIPTION	BU82	REMARKS
1	BG6-E1102-00	CYLINDER HEAD ASSY	1	
2	B74-E1133-10	.GUIDE, VALVE 1	4	
3	90340-18002	.PLUG, STRAIGHT SCREW	1	
4	95022-06012	BOLT, FLANGE	1	
5	90430-06014	GASKET	1	
6	95612-08620	BOLT, STUD	2	
7	B74-E1998-00	BRACKET 1	1	
8	95022-06012	BOLT, FLANGE	1	
9	B74-E1191-00	COVER, CYLINDER HEAD 1	1	
10	B74-E1185-00	COVER, CYLINDER HEAD SIDE 3	1	
11	B74-E1169-00	GASKET, BREATHER COVER	1	
12	95022-06016	BOLT, FLANGE	3	
13	B74-E1193-00	GASKET, HEAD COVER 1	1	
14	B74-E1999-00	BRACKET 2	1	
15	95022-06025	BOLT, FLANGE	6	
16	90179-10818	NUT	4	
17	90201-10849	WASHER, PLATE	4	
18	B74-11391-00	BOLT, STUD 1	4	
19	94700-00436	PLUG, SPARK (NGK LMAR8A-9)	1	
20	B74-E1181-00	GASKET, CYLINDER HEAD 1	1	
21	99530-14016	PIN, DOWEL	2	
22	99530-14016	PIN, DOWEL	2	
23	90110-06868	BOLT, HEXAGON SOCKET HEAD	2	
24	BG6-E1311-01	CYLINDER 1	1	
25	B74-E1351-00	GASKET, CYLINDER	1	



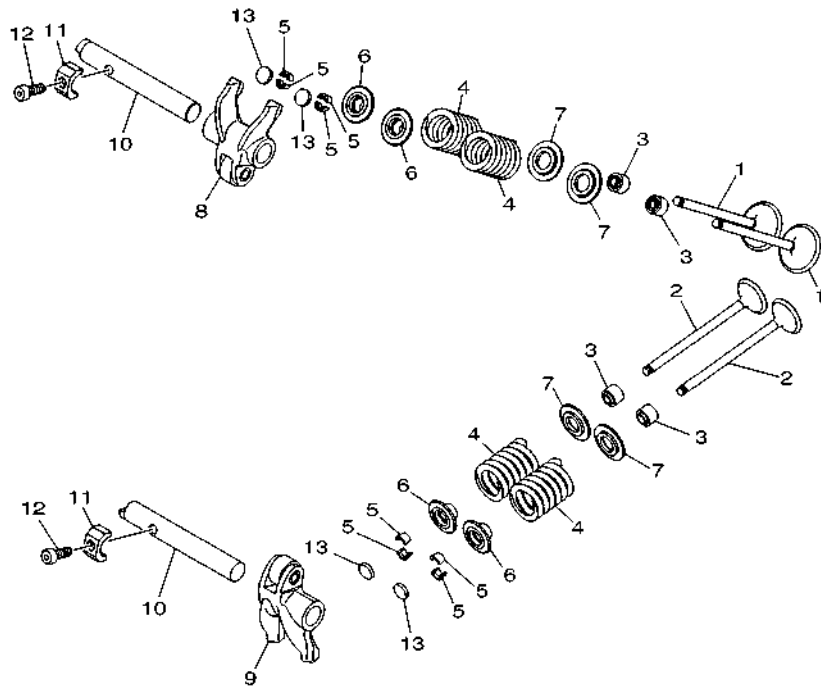
  
 BG61460-S020

**FIG. 2 CRANKSHAFT & PISTON**

REF. NO.	PART NO.	DESCRIPTION	BU82	REMARKS
1	BG6-E1400-00	CRANKSHAFT ASSY	1	
2	BG6-11650-00	CONNECTING ROD ASSY	1	
3	2C0-11654-00	.BOLT, CONNECTING ROD	2	
4	90179-07001	.NUT	2	
5	B74-11656-00	PLANE BEARING, CONNECTING ROD	2	UR BLUE
	B74-11656-10	PLANE BEARING, CONNECTING ROD	2	UR BLACK
	B74-11656-20	PLANE BEARING, CONNECTING ROD	2	UR BROWN
	B74-11656-30	PLANE BEARING, CONNECTING ROD	2	UR GREEN
6	90105-10883	BOLT, FLANGE	1	
7	90201-10848	WASHER, PLATE	1	
8	90280-05013	KEY, WOODRUFF	1	
9	B74-11416-A0	PLANE BEARING, CRANKSHAFT 1	2	UR WHITE
	B74-11416-00	PLANE BEARING, CRANKSHAFT 1	2	UR BLUE
	B74-11416-10	PLANE BEARING, CRANKSHAFT 1	2	UR BLACK
	B74-11416-20	PLANE BEARING, CRANKSHAFT 1	2	UR BROWN
	B74-11416-30	PLANE BEARING, CRANKSHAFT 1	2	UR GREEN
	B74-11416-40	PLANE BEARING, CRANKSHAFT 1	2	UR YELLOW
	B74-11416-50	PLANE BEARING, CRANKSHAFT 1	2	UR PINK
10	B74-11417-A0	PLANE BEARING, CRANKSHAFT 2	2	UR WHITE
	B74-11417-00	PLANE BEARING, CRANKSHAFT 2	2	UR BLUE
	B74-11417-10	PLANE BEARING, CRANKSHAFT 2	2	UR BLACK
	B74-11417-20	PLANE BEARING, CRANKSHAFT 2	2	UR BROWN
	B74-11417-30	PLANE BEARING, CRANKSHAFT 2	2	UR GREEN
	B74-11417-40	PLANE BEARING, CRANKSHAFT 2	2	UR YELLOW
	B74-11417-50	PLANE BEARING, CRANKSHAFT 2	2	UR PINK
11	BG6-E1500-00	BALANCER ASSY	1	
12	93306-303YT	BEARING	1	



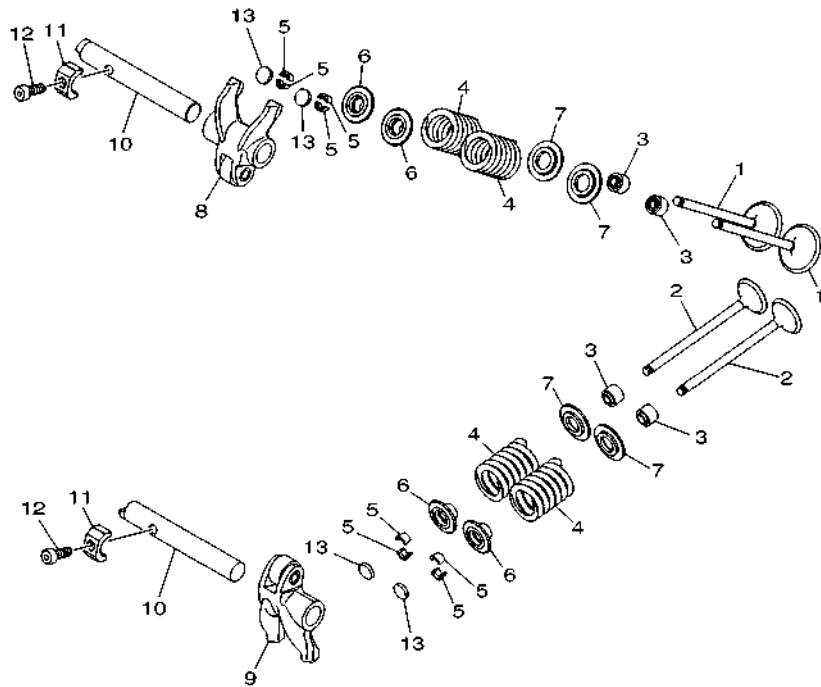




  
 B741300-S030

**FIG. 3 VALVE**

REF. NO.	PART NO.	DESCRIPTION	BU82				REMARKS
1	B74-E2111-00	VALVE, INTAKE	2				
2	B74-E2121-00	VALVE, EXHAUST	2				
3	54P-E2119-00	SEAL, VALVE STEM	4				
4	B74-E2113-00	SPRING, VALVE INNER	4				
5	5TL-E2118-00	LOCK, VALVE SPRING RETAINER	8				
6	B74-E2117-00	RETAINER, VALVE SPRING	4				
7	2PH-E2126-00	SEAT, VALVE SPRING 2	4				
8	B74-E2151-00	ARM, VALVE ROCKER	1				
9	B74-E2161-00	ARM, VALVE ROCKER 2	1				
10	B74-E2146-00	SHAFT, ROCKER	2				
11	B74-E2662-00	COLLAR 1	2				
12	91312-05014	BOLT, HEXAGON SOCKET HEAD	2				
13	B74-12168-00	PAD, ADJUSTING (1.50)	4				UR
	B74-12168-20	PAD, ADJUSTING (1.55)	4				UR
	B74-12168-40	PAD, ADJUSTING (1.60)	4				UR
	B74-12168-60	PAD, ADJUSTING (1.65)	4				UR
	B74-12168-80	PAD, ADJUSTING (1.70)	4				UR
	B74-12168-A0	PAD, ADJUSTING (1.75)	4				UR
	B74-12168-F0	PAD, ADJUSTING (1.80)	4				UR
	B74-12168-H0	PAD, ADJUSTING (1.85)	4				UR
	B74-12168-K0	PAD, ADJUSTING (1.90)	4				UR
	B74-12168-M0	PAD, ADJUSTING (1.95)	4				UR
	B74-12168-R0	PAD, ADJUSTING (2.00)	4				UR
	B74-12168-U0	PAD, ADJUSTING (2.05)	4				UR
	B74-12168-W0	PAD, ADJUSTING (2.10)	4				UR
	B74-12168-Y0	PAD, ADJUSTING (2.15)	4				UR
	B74-12169-10	PAD, ADJUSTING (2.20)	4				UR

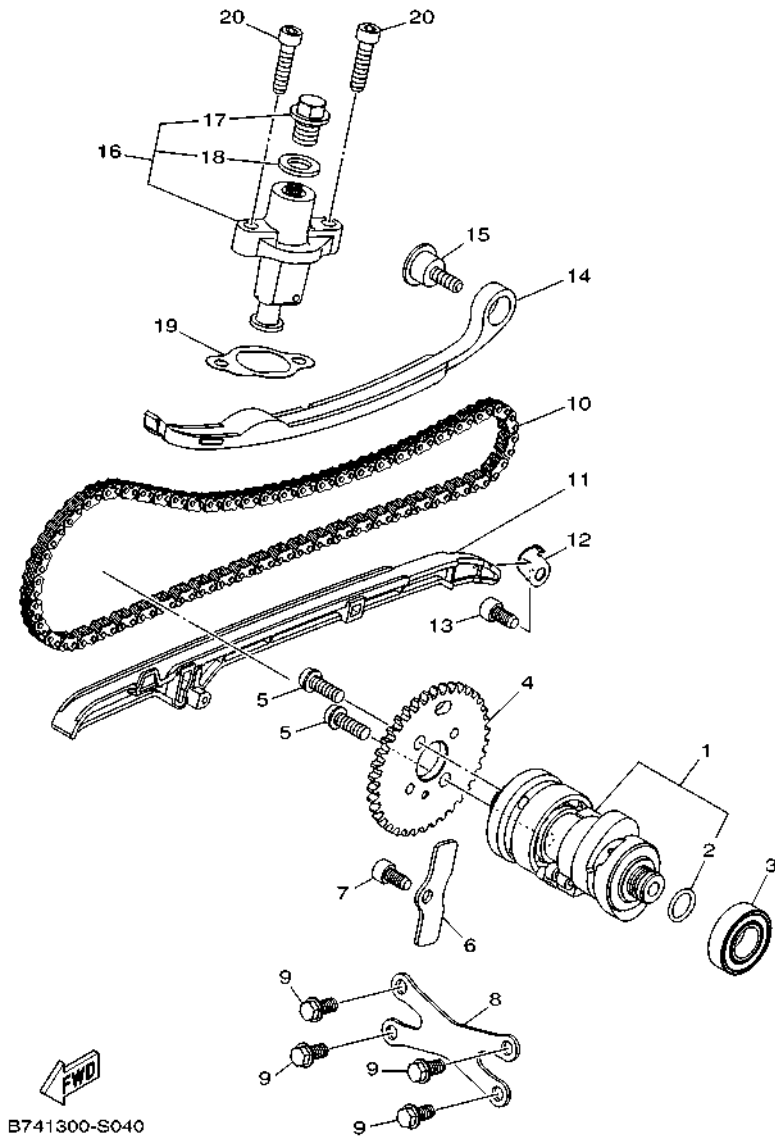


  
 B741300-S030

**FIG. 3 VALVE**

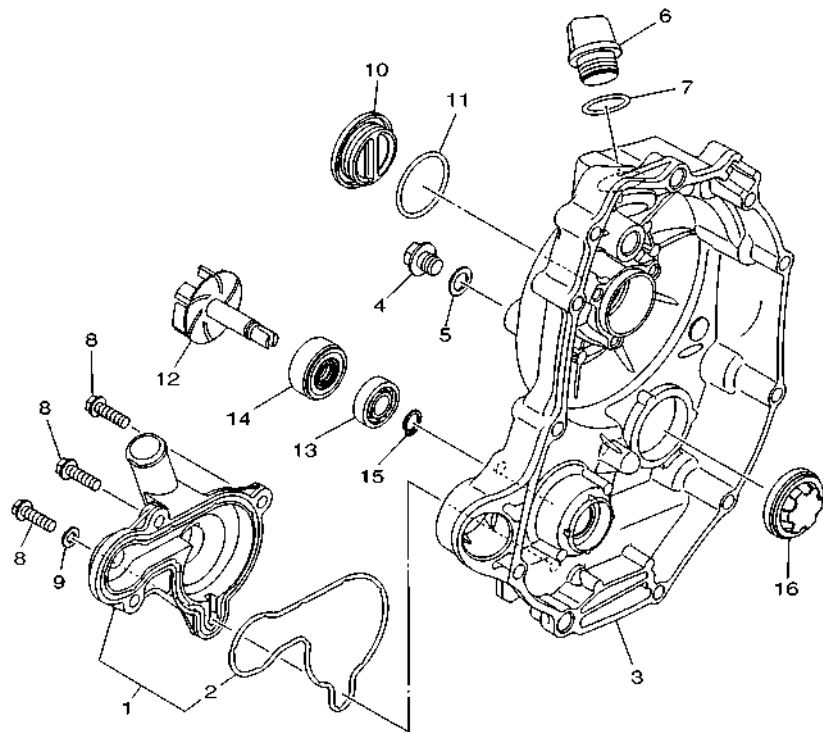
REF. NO.	PART NO.	DESCRIPTION	BU82			REMARKS
13	B74-12169-30	PAD, ADJUSTING (2.25)	4			UR
	B74-12169-50	PAD, ADJUSTING (2.30)	4			UR
	B74-12169-70	PAD, ADJUSTING (2.35)	4			UR
	B74-12169-90	PAD, ADJUSTING (2.40)	4			UR
	B74-12169-E0	PAD, ADJUSTING (2.45)	4			UR
	B74-12169-G0	PAD, ADJUSTING (2.50)	4			UR
	B74-12169-J0	PAD, ADJUSTING (2.55)	4			UR
	B74-12169-L0	PAD, ADJUSTING (2.60)	4			UR
	B74-12169-N0	PAD, ADJUSTING (2.65)	4			UR
	B74-12169-T0	PAD, ADJUSTING (2.70)	4			UR
	B74-12169-V0	PAD, ADJUSTING (2.75)	4			UR
	B74-12169-X0	PAD, ADJUSTING (2.80)	4			UR
	B74-1216A-00	PAD, ADJUSTING (2.85)	4			UR
	B74-1216A-20	PAD, ADJUSTING (2.90)	4			UR
	B74-1216A-40	PAD, ADJUSTING (2.95)	4			UR
	B74-1216A-60	PAD, ADJUSTING (3.00)	4			UR
	B74-1216A-80	PAD, ADJUSTING (3.05)	4			UR
	B74-1216A-A0	PAD, ADJUSTING (3.10)	4			UR
	B74-1216A-F0	PAD, ADJUSTING (3.15)	4			UR
	B74-1216A-H0	PAD, ADJUSTING (3.20)	4			UR
	B74-1216A-K0	PAD, ADJUSTING (3.25)	4			UR
	B74-1216A-M0	PAD, ADJUSTING (3.30)	4			UR
	B74-1216A-R0	PAD, ADJUSTING (3.35)	4			UR
	B74-1216A-U0	PAD, ADJUSTING (3.40)	4			UR
	B74-1216A-W0	PAD, ADJUSTING (3.45)	4			UR
	B74-1216A-Y0	PAD, ADJUSTING (3.50)	4			UR

**FIG. 4 CAMSHAFT & CHAIN**



REF. NO.	PART NO.	DESCRIPTION	BU82				REMARKS
1	BG6-E2170-00	CAMSHAFT ASSY 1	1				
2	93210-12801	.O-RING	1				
3	93306-002XH	BEARING	1				
4	B74-E2176-00	SPROCKET, CAM CHAIN	1				
5	90110-06405	BOLT, HEXAGON SOCKET HEAD	2				
6	B74-E112F-00	PLATE 2	1				
7	90110-06187	BOLT, HEXAGON SOCKET HEAD	1				
8	B74-E111F-00	PLATE	1				
9	95022-06012	BOLT, FLANGE	4				
10	94568-H8110	CHAIN	1				
11	B74-E2231-00	GUIDE, STOPPER 1	1				
12	B74-E2233-00	PLATE, GUIDE STOPPER 1	1				
13	90110-06182	BOLT, HEXAGON SOCKET HEAD	1				
14	B74-E2241-00	GUIDE, STOPPER 2	1				
15	1DB-E2228-00	BOLT	1				
16	31G-12210-01	TENSIONER ASSY, CAM CHAIN	1				
17	31G-12222-00	.PLUG	1				
18	31G-12214-00	.GASKET	1				
19	B74-E2213-00	GASKET, TENSIONER CASE	1				
20	91312-06025	BOLT, HEXAGON SOCKET HEAD	2				

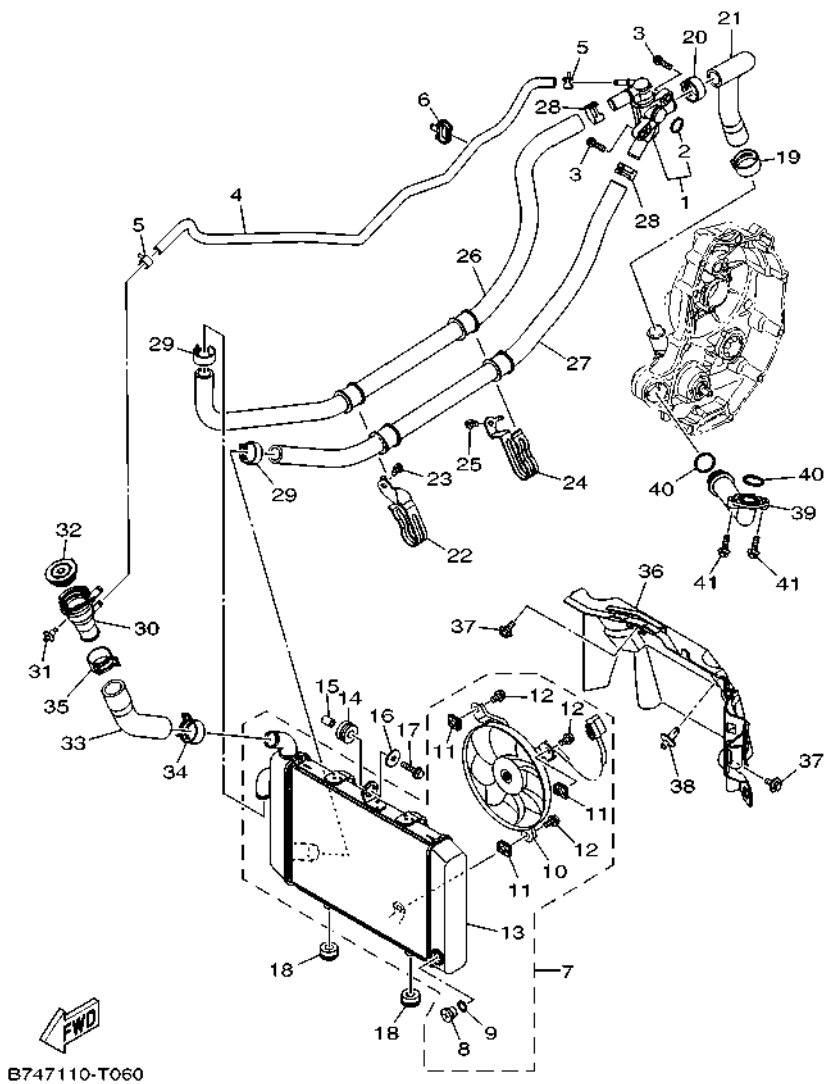
**FIG. 5 WATER PUMP**



REF. NO.	PART NO.	DESCRIPTION	BU82				REMARKS
1	B74-E2422-00	COVER, HOUSING	1				
2	B74-E2439-00	.O-RING	1				
3	B74-E5417-00	COVER, CAP	1				
4	B74-E2157-00	BOLT	1				
5	90430-10148	GASKET	1				
6	5BP-E5363-10	PLUG, OIL	1				
7	93210-198J0	O-RING	1				
8	95027-06020	BOLT, FLANGE	3				
9	90430-06014	GASKET	1				
10	90340-32805	PLUG, STRAIGHT SCREW	1				
11	93210-32816	O-RING	1				
12	B74-E2450-00	IMPELLER SHAFT ASSY	1				
13	93306-000Y3	BEARING	1				
14	93103-10801	OIL SEAL	1				
15	99009-10400	CIRCLIP	1				
16	5PW-15361-00	GAUGE, LEVEL	1				

 B741300-S050

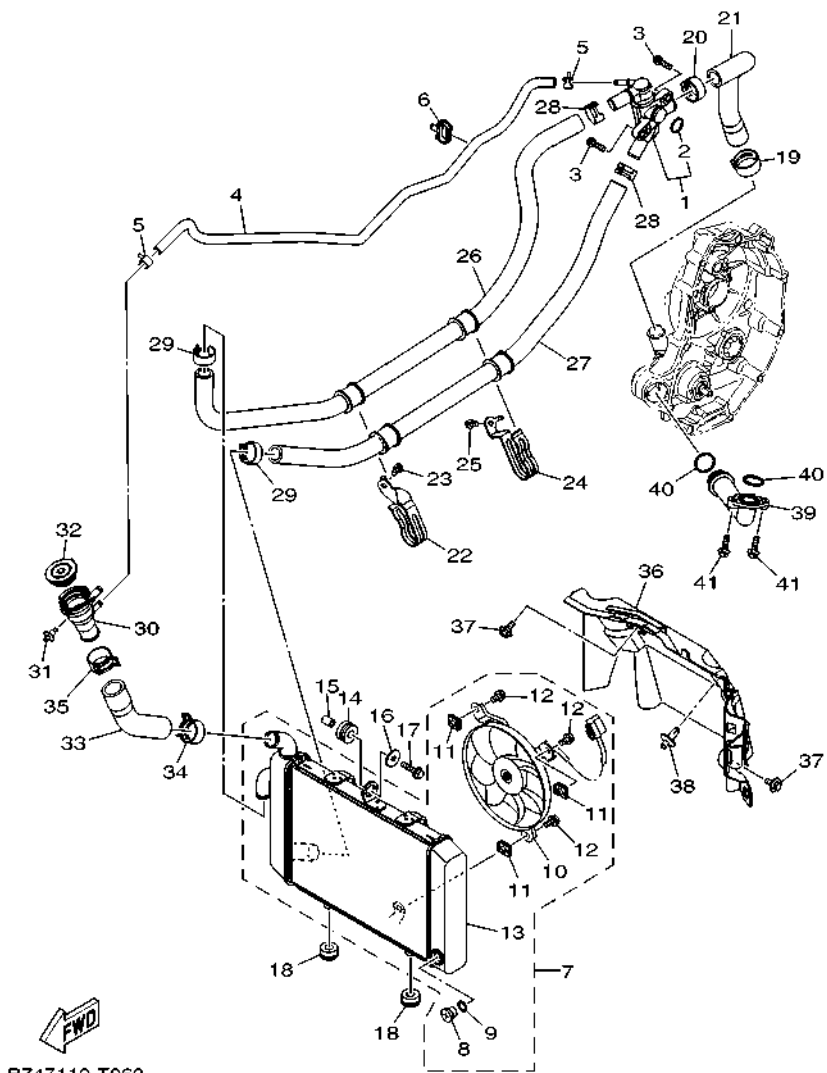
**FIG. 6 RADIATOR & HOSE**



B747110-T060

REF. NO.	PART NO.	DESCRIPTION	BU82				REMARKS
1	B74-12410-00	THERMOSTAT ASSY	1				
2	52S-12439-00	.O-RING	1				
3	95022-06020	BOLT, FLANGE	2				
4	B74-E2576-00	HOSE 1	1				
5	90467-10038	CLIP	2				
6	90464-10802	CLAMP	1				
7	B74-E240A-00	RADIATOR ASSY	1				
8	5ST-E2615-00	.COCK, DRAIN	1				
9	5ST-E2843-00	.O-RING	1				
10	B74-E2405-00	.BLOWER ASSY	1				
11	1WD-E2671-00	.NUT 1	3				
12	5GJ-12675-00	.BOLT, BLOWER HOLDING	3				
13	B74-E2461-00	.RADIATOR COMP	1				
14	90480-15483	GROMMET	1				
15	90387-064W3	COLLAR	1				
16	90201-06033	WASHER, PLATE	1				
17	95827-06025	BOLT, FLANGE	1				
18	90480-14818	GROMMET	2				
19	90467-22002	CLIP	1				
20	90467-24800	CLIP	1				
21	B74-E2481-00	PIPE 1	1				
22	B74-F1823-00	CLAMP, HOSE	1				
23	95022-06012	BOLT, FLANGE	1				
24	B74-F2591-00	CLAMP, HOSE	1				
25	95022-06012	BOLT, FLANGE	1				
26	B74-E2482-00	PIPE 2	1				
27	B74-E2483-00	PIPE 3	1				

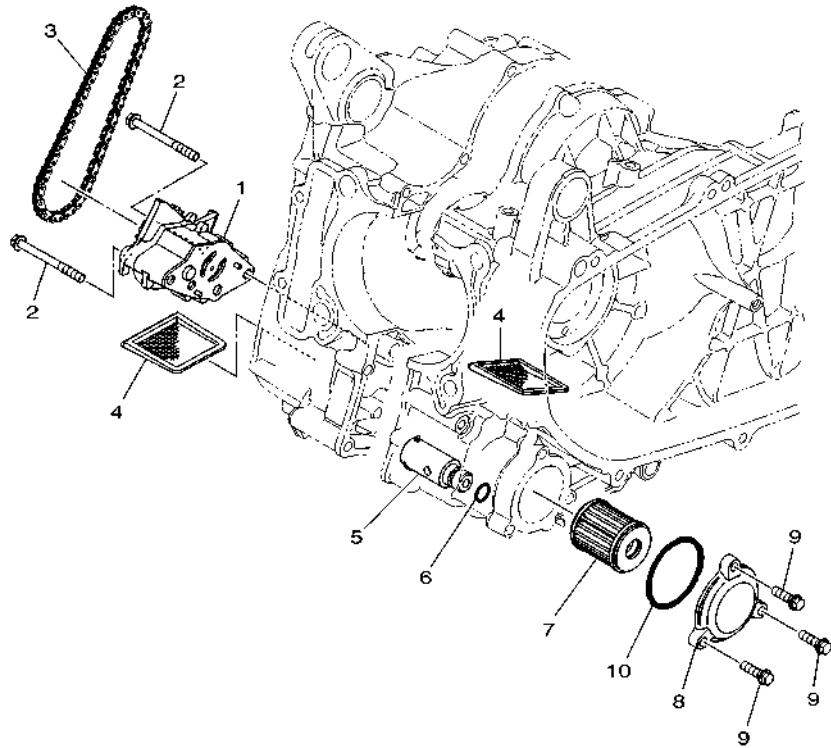
**FIG. 6 RADIATOR & HOSE**



B747110-T060

REF. NO.	PART NO.	DESCRIPTION	BU82				REMARKS
28	90467-20805	CLIP	2				
29	90467-21801	CLIP	2				
30	B74-E2591-00	SUPT, FILLER NECK	1				
31	90269-07007	RIVET	1				
32	B65-E2462-00	CAP, RADIATOR	1				
33	B74-E2484-00	PIPE 4	1				
34	90467-250A1	CLIP	1				
35	90467-26131	CLIP	1				
36	B74-E2467-00	COVER, RADIATOR	1				
37	90109-06887	BOLT	2				
38	90269-06816	RIVET	1				
39	B74-E2446-00	JOINT	1				
40	93210-22800	O-RING	2				
41	95827-06020	BOLT, FLANGE	2				

**FIG. 7 OIL PUMP**

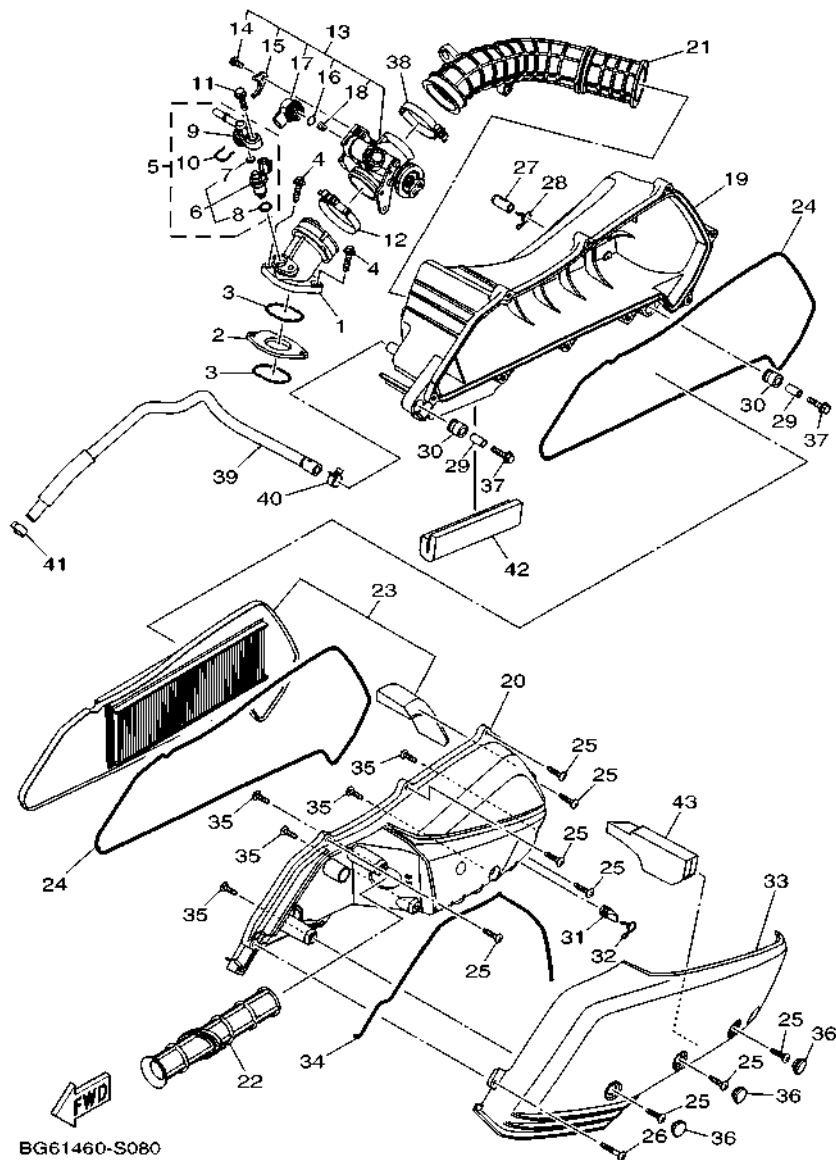


REF. NO.	PART NO.	DESCRIPTION	BU82				REMARKS
1	B74-E3300-00	OIL PUMP ASSY	1				
2	95022-06060	BOLT, FLANGE	2				
3	94568-F9058	CHAIN	1				
4	4ST-E3411-00	STRAINER, OIL	2				
5	5RU-13490-00	RELIEF VALVE ASSY	1				
6	93210-10096	O-RING	1				
7	1S7-E3440-00	ELEMENT ASSY, OIL CLEANER	1				
8	B74-E3447-00	COVER, OIL ELEMENT	1				
9	95022-06020	BOLT, FLANGE	3				
10	93210-48530	O-RING	1				



B741300-S070

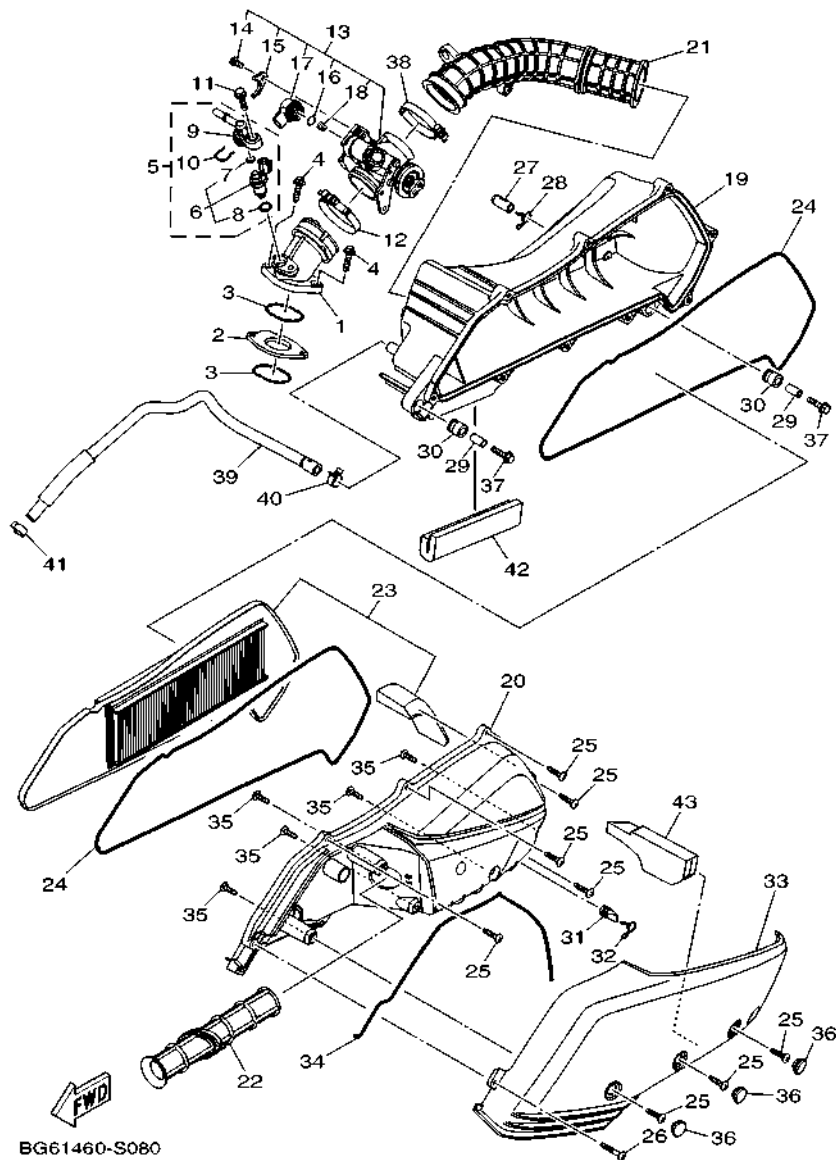
FIG. 8 INTAKE



REF. NO.	PART NO.	DESCRIPTION	BU82				REMARKS
1	BG6-E3585-00	MANIFOLD	1				
2	BG6-E3595-00	JOINT	1				
3	93210-40659	O-RING	2				
4	90110-06172	BOLT, HEXAGON SOCKET HEAD	2				
5	BG6-E3770-00	INJECTOR ASSY	1				
6	BG6-E3761-00	.INJECTOR	1				
7	54P-E4147-00	.O-RING	1				
8	5CA-E4147-00	.O-RING	1				
9	52S-13938-00	.PIPE	1				
10	54P-E4137-00	.CLIP	1				
11	95812-06025	BOLT, FLANGE	1				
12	90450-56009	HOSE CLAMP ASSY	1				
13	BG6-E3750-01	THROTTLE BODY ASSY	1				
14	98502-06012	.SCREW, PAN HEAD	1				
15	54P-E4243-00	.PLATE	1				
16	54P-E416A-00	.O-RING	1				
17	B74-H5801-00	.STEPPING MOTOR	1				
18	B74-E4335-00	.SPRING, PLUNGER	1				
19	BG6-E4411-00	CASE, AIR CLEANER 1	1				
20	B74-E4412-00	CAP, CLEANER CASE 1	1				
21	BG6-E4469-00	FUNNEL, AIR	1				
22	B74-E4437-00	DUCT	1				
23	B74-WE445-00	AIR CLEANER ELEMENT ASSY	1				
24	B74-E4452-00	SEAL	2				
25	97707-50025	SCREW, TAPPING	8				
26	97707-50035	SCREW, TAPPING	1				
27	52B-E443E-00	PIPE, DRAIN	1				

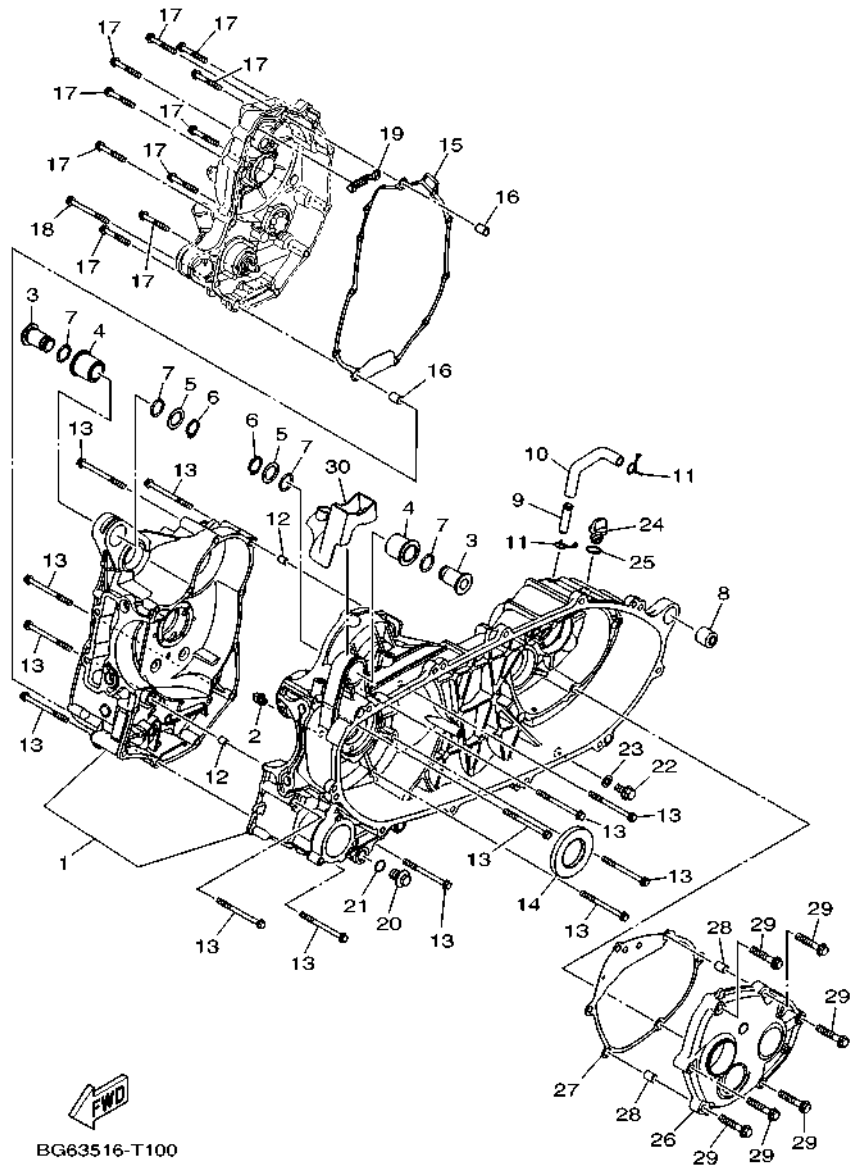


FIG. 8 INTAKE



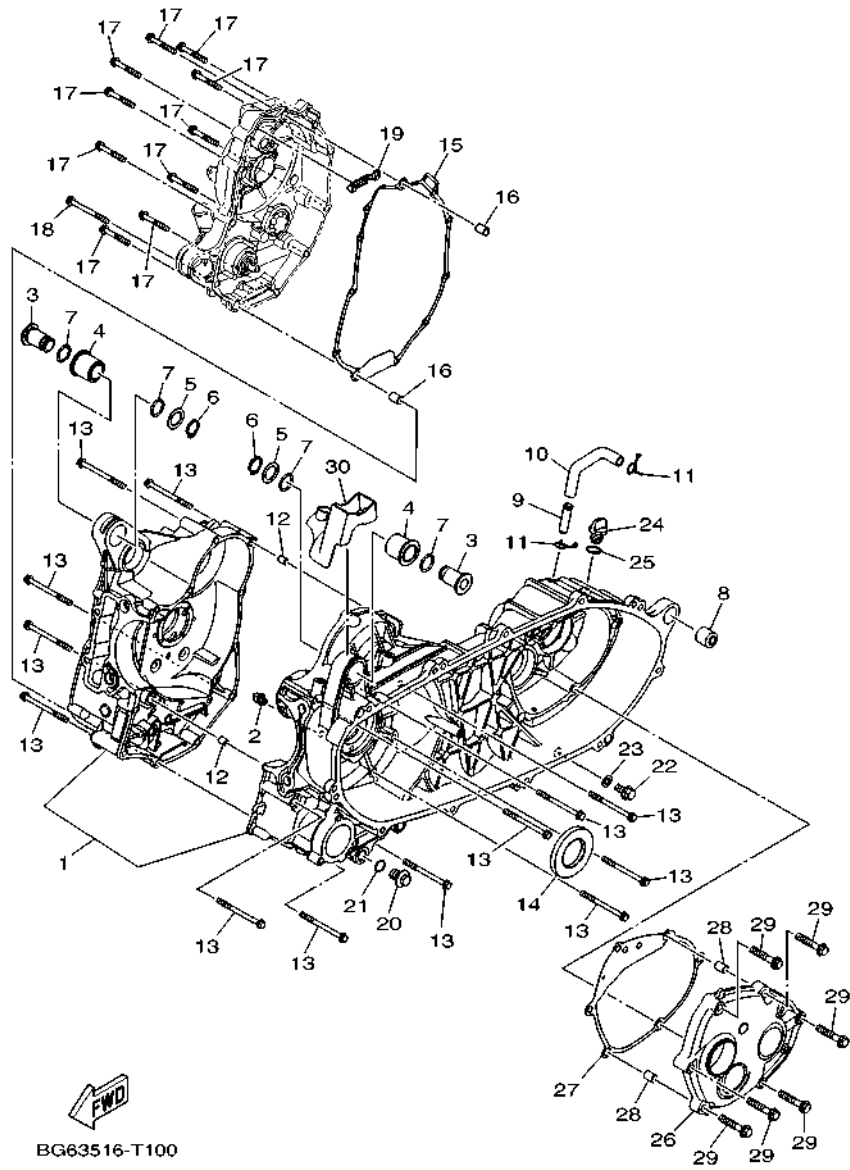
REF. NO.	PART NO.	DESCRIPTION	BU82				REMARKS
28	90467-12809	CLIP	1				
29	B74-E4449-00	COLLAR	2				
30	B74-E4435-00	GROMMET	2				
31	5TP-E443G-10	PIPE, DRAIN 2	1				
32	90467-12809	CLIP	1				
33	B74-E4417-00	COVER 1	1				
34	B74-E4462-00	SEAL	1				
35	97702-50020	SCREW, TAPPING	5				
36	90338-14802	PLUG	3				
37	95812-06030	BOLT, FLANGE	2				
38	90450-52008	HOSE CLAMP ASSY	1				
39	B74-E1166-00	PIPE, BREATHER 1	1				
40	90467-13808	CLIP	1				
41	90467-14807	CLIP	1				
42	90520-10836	DAMPER, PLATE	1				
43	B74-E447F-00	ELEMENT 3	1				





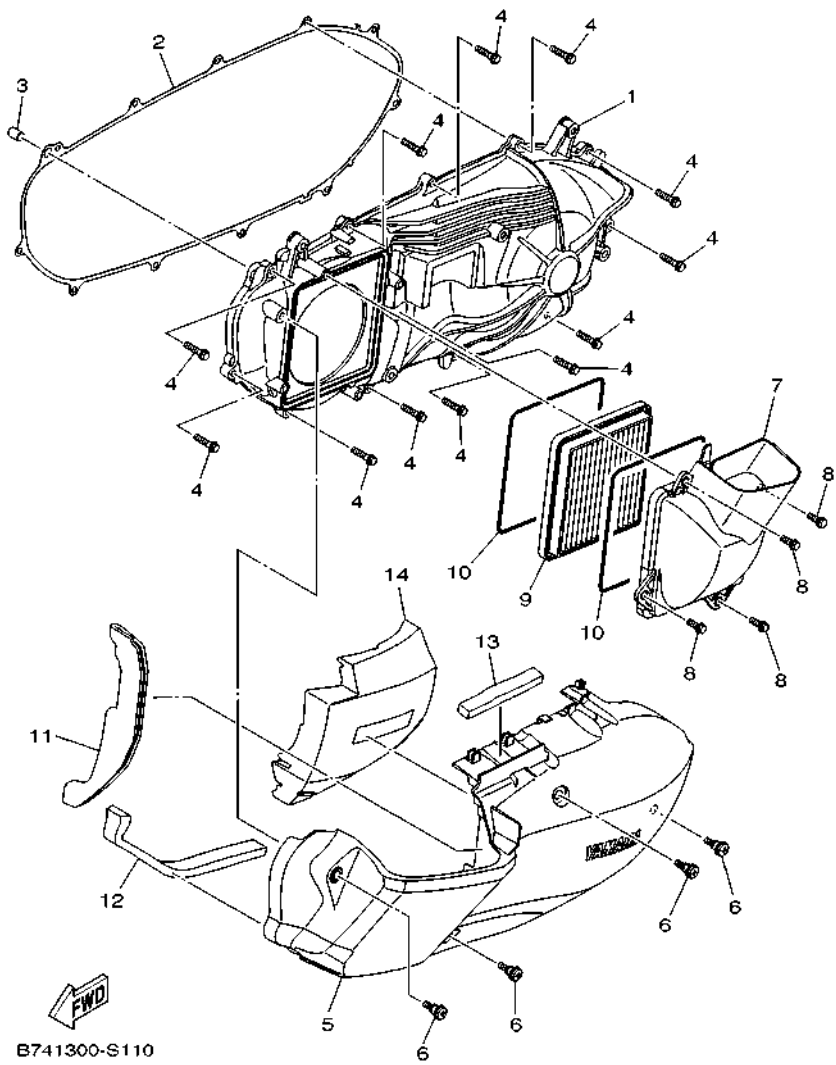
**FIG. 10 CRANKCASE**

REF. NO.	PART NO.	DESCRIPTION	BU82				REMARKS
1	B74-E5150-00	CRANKCASE ASSY	1				
2	5D9-E5155-00	NOZZLE 3	1				
3	B74-E5372-00	COLLAR, UNION	2				
4	B74-E5378-00	HOLDER	2				
5	90201-18262	WASHER, PLATE	2				
6	99009-18400	CIRCLIP	2				
7	93210-18397	O-RING	4				
8	5MX-F2216-00	BUSH, REAR SHOCK ABSORBER	1				
9	40D-E1126-00	PIPE, BREATHER 3	1				
10	B74-E5373-00	PIPE, BREATHER	1				
11	90467-12052	CLIP	2				
12	99530-08012	PIN, DOWEL	2				
13	95022-06070	BOLT, FLANGE	13				
14	93102-35805	OIL SEAL	1				
15	B74-E5453-00	GASKET	1				
16	91810-14809	PIN, DOWEL	2				
17	95022-06040	BOLT, FLANGE	10				
18	95022-06060	BOLT, FLANGE	1				
19	2PV-E5113-00	PLATE	1				
20	90340-12808	PLUG, STRAIGHT SCREW	1				
21	4YS-E1198-00	GASKET	1				
22	95812-08016	BOLT, FLANGE	1				
23	90430-08119	GASKET	1				
24	5LW-E5363-00	PLUG, OIL	1				
25	93210-14816	O-RING	1				
26	B74-E5421-00	COVER, CRANKCASE 2	1				
27	B74-E5461-00	GASKET, CRANKCASE COVER 2	1				



**FIG. 10 CRANKCASE**

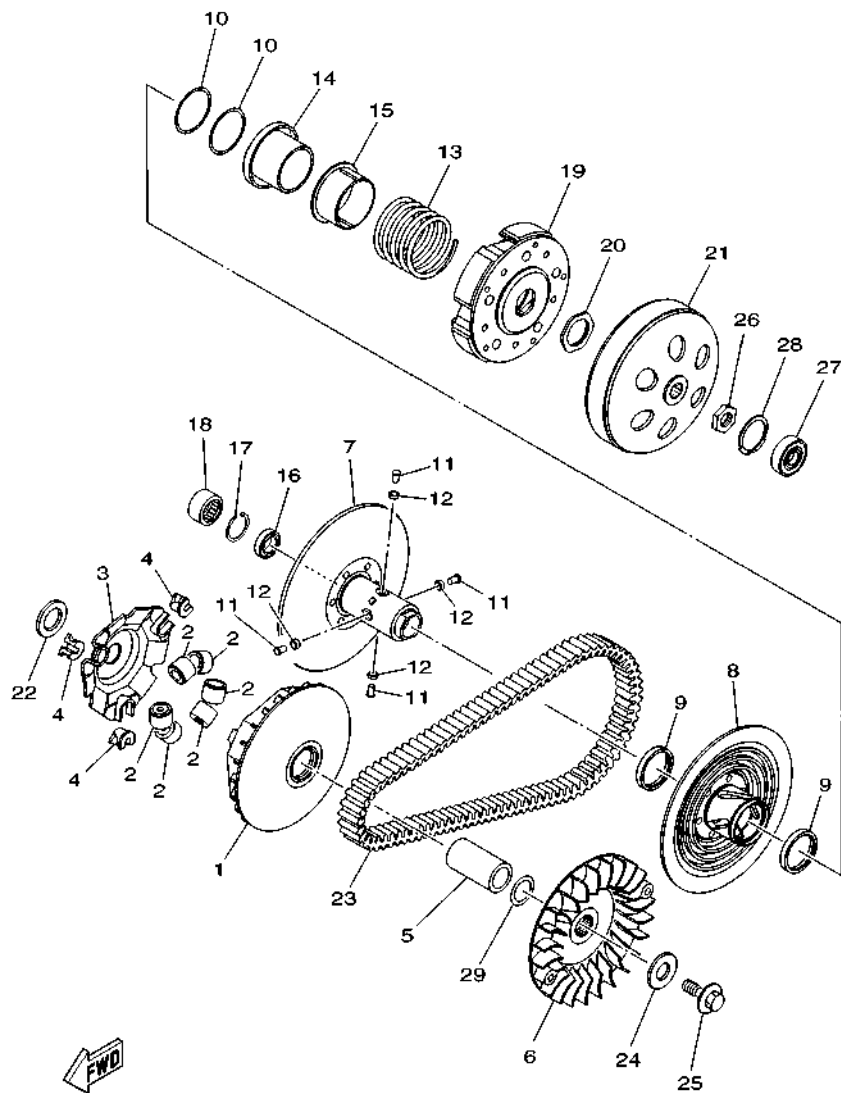
REF. NO.	PART NO.	DESCRIPTION	BU82				REMARKS
28	91810-14809	PIN, DOWEL	2				
29	95022-08040	BOLT, FLANGE	6				
30	B74-H1639-00	COVER	1				
<hr/>							
<hr/>							
<hr/>							
<hr/>							
<hr/>							
<hr/>							
<hr/>							
<hr/>							
<hr/>							
<hr/>							



**FIG. 11 CRANKCASE COVER 1**

REF. NO.	PART NO.	DESCRIPTION	BU82				REMARKS
1	B74-E5411-00	COVER, CRANKCASE 1	1				
2	B74-E5451-00	GASKET, CRANKCASE COVER 1	1				
3	91810-14809	PIN, DOWEL	1				
4	95022-06025	BOLT, FLANGE	12				
5	B74-E5431-00	COVER, CRANKCASE 3	1				
6	2DP-E5481-00	BOLT 1	4				
7	B74-E5471-00	DUCT, AIR	1				
8	95027-06016	BOLT, FLANGE	4				
9	B74-E5407-00	ELEMENT 1	1				
10	B74-E5474-00	SEAL, AIR DUCT	2				
11	90520-10837	DAMPER, PLATE	1				
12	90520-20821	DAMPER, PLATE	1				
13	90520-10835	DAMPER, PLATE	1				
14	B74-15338-00	DAMPER 5	1				





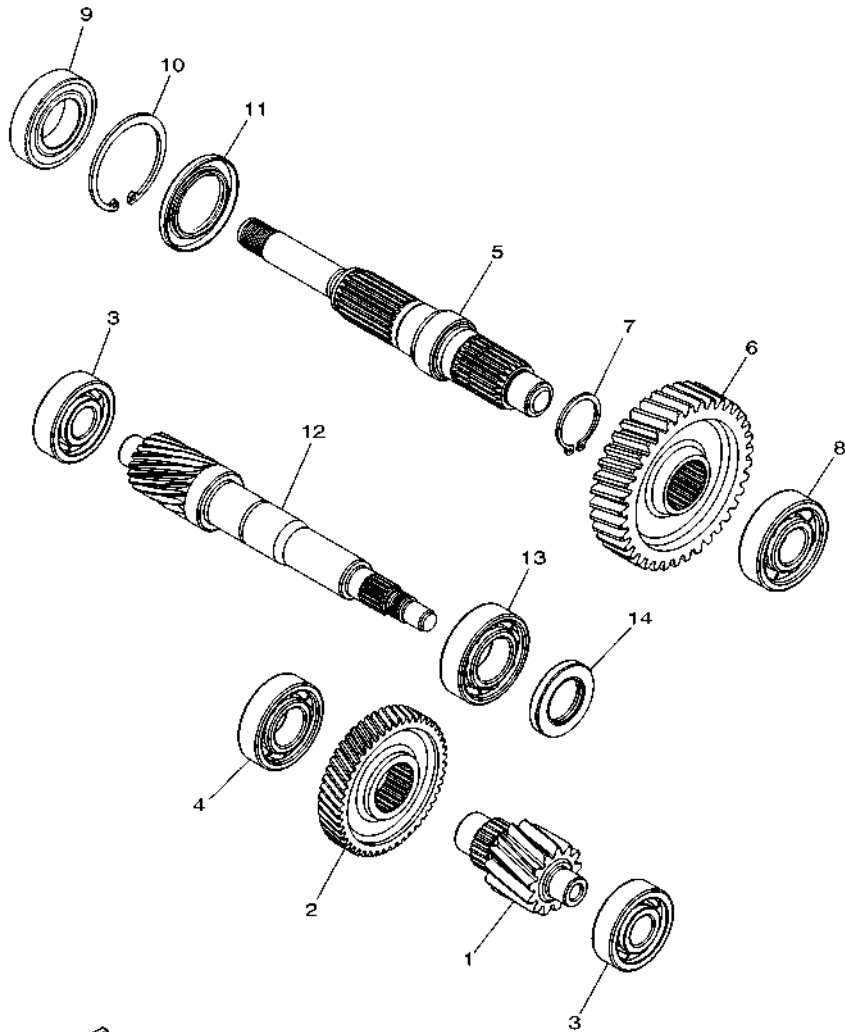
BG61460-S130

FIG. 13 CLUTCH

REF. NO.	PART NO.	DESCRIPTION	BU82	REMARKS
1	B74-E7620-00	PRIMARY SLIDING SHEAVE COMP.	1	
2	B74-E7632-00	WEIGHT	6	
3	B74-E7623-00	CAM	1	
4	B74-E7653-00	SLIDER	3	
5	B74-E7674-00	COLLAR, GUIDE	1	
6	B74-E7611-00	SHEAVE, PRIMARY FIXED	1	
7	B74-E7660-00	SECONDARY FIXED SHEAVE COMP.	1	
8	BG6-E7670-00	SECONDARY SLIDING SHEAVE	1	
9	B74-E7465-00	SEAL	2	
10	B74-E7465-10	SEAL	2	
11	B74-E7664-00	PIN, GUIDE	4	
12	B74-E7674-10	COLLAR, GUIDE	4	
13	B74-E7683-00	SPRING, SECONDARY	1	
14	B74-E7684-00	SEAT, SECONDARY SPRING	1	
15	B74-E7644-00	SEAT, SPRING	1	
16	B74-E7678-01	BEARING	1	
17	B74-E5744-00	CIRCLIP	1	
18	B74-E7678-10	BEARING	1	
19	B74-E6620-00	CLUTCH CARRIER ASSY	1	
20	B74-E7668-00	NUT	1	
21	B74-E6611-00	CLUTCH HOUSING COMP.	1	
22	90201-23015	WASHER, PLATE	1	
23	B74-E7641-00	V-BELT	1	
24	90201-19014	WASHER, PLATE	1	
25	90105-12807	BOLT, FLANGE	1	
26	90170-14802	NUT	1	
27	B74-E7412-00	BEARING	1	





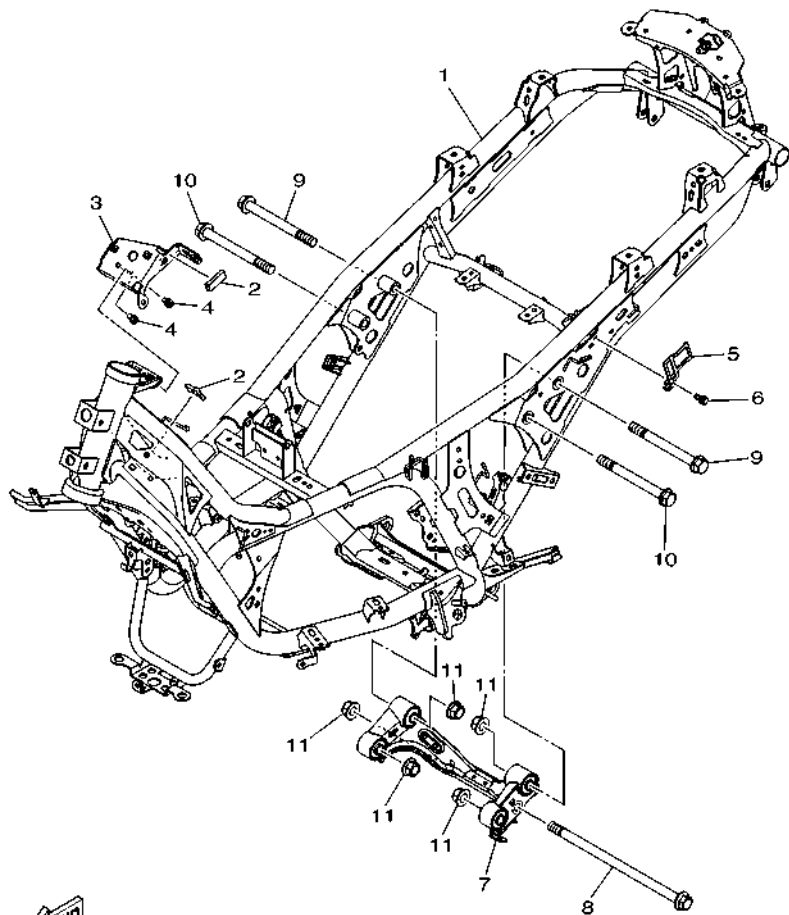


B741300-S140

**FIG. 14 TRANSMISSION**

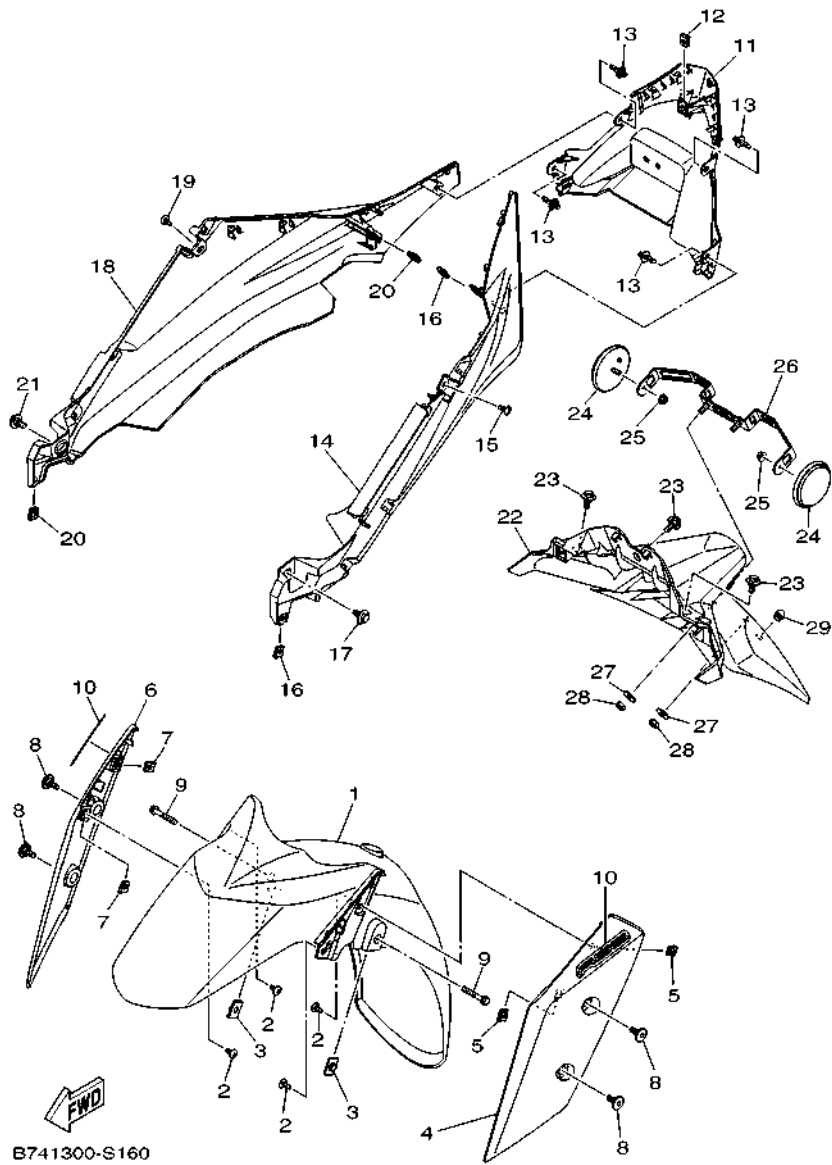
REF. NO.	PART NO.	DESCRIPTION	BU82	REMARKS
1	B74-17411-00	AXLE, MAIN (13T)	1	
2	B74-E6151-00	GEAR, PRIMARY DRIVEN (48T)	1	
3	93306-303YT	BEARING	2	
4	93306-272YC	BEARING	1	
5	B74-E7421-00	AXLE, DRIVE	1	
6	B74-E7211-00	GEAR, 1ST WHEEL (37T)	1	
7	99009-28400	CIRCLIP	1	
8	93306-304YW	BEARING	1	
9	93306-078Y1	BEARING	1	
10	99009-52500	CIRCLIP	1	
11	93102-35806	OIL SEAL	1	
12	B74-E6111-00	GEAR, PRIMARY DRIVE (18D)	1	
13	93300-205Y0	BEARING	1	
14	93102-25826	OIL SEAL	1	

**FIG. 15 FRAME**



B741300-S150

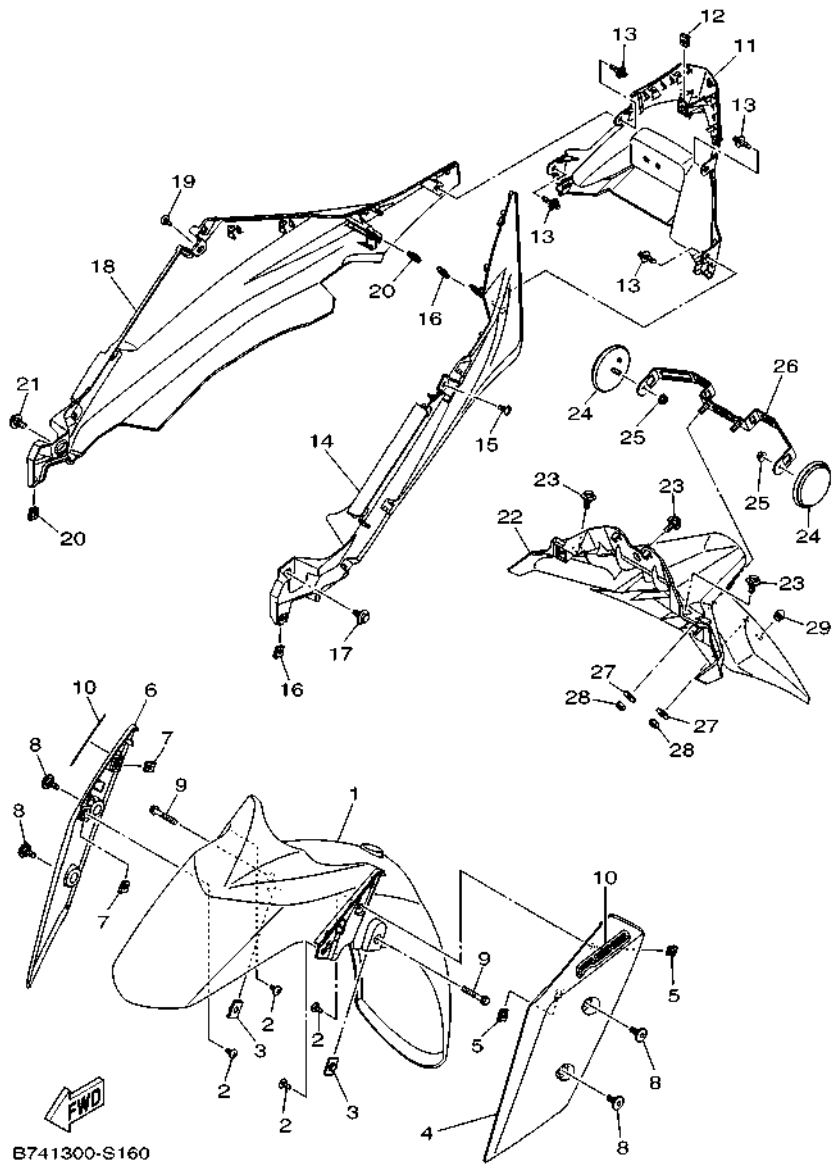
REF. NO.	PART NO.	DESCRIPTION	BU82				REMARKS
1	B74-F1110-01	FRAME COMP.	1				
2	90520-04015	DAMPER, PLATE	2				
3	B74-H251P-00	BRACKET, MAIN SWITCH	1				
4	95022-06012	BOLT, FLANGE	2				
5	B74-F149S-00	BRACKET 5	1				
6	95022-06012	BOLT, FLANGE	1				
7	B74-F1400-02	ENGINE BRACKET COMP.	1				
8	B74-F2141-00	SHAFT, PIVOT	1				
9	90105-12806	BOLT, FLANGE	2				
10	90105-12805	BOLT, FLANGE	2				
11	95602-12200	NUT, SELF-LOCKING	5				



B741300-S160

FIG. 16 FENDER

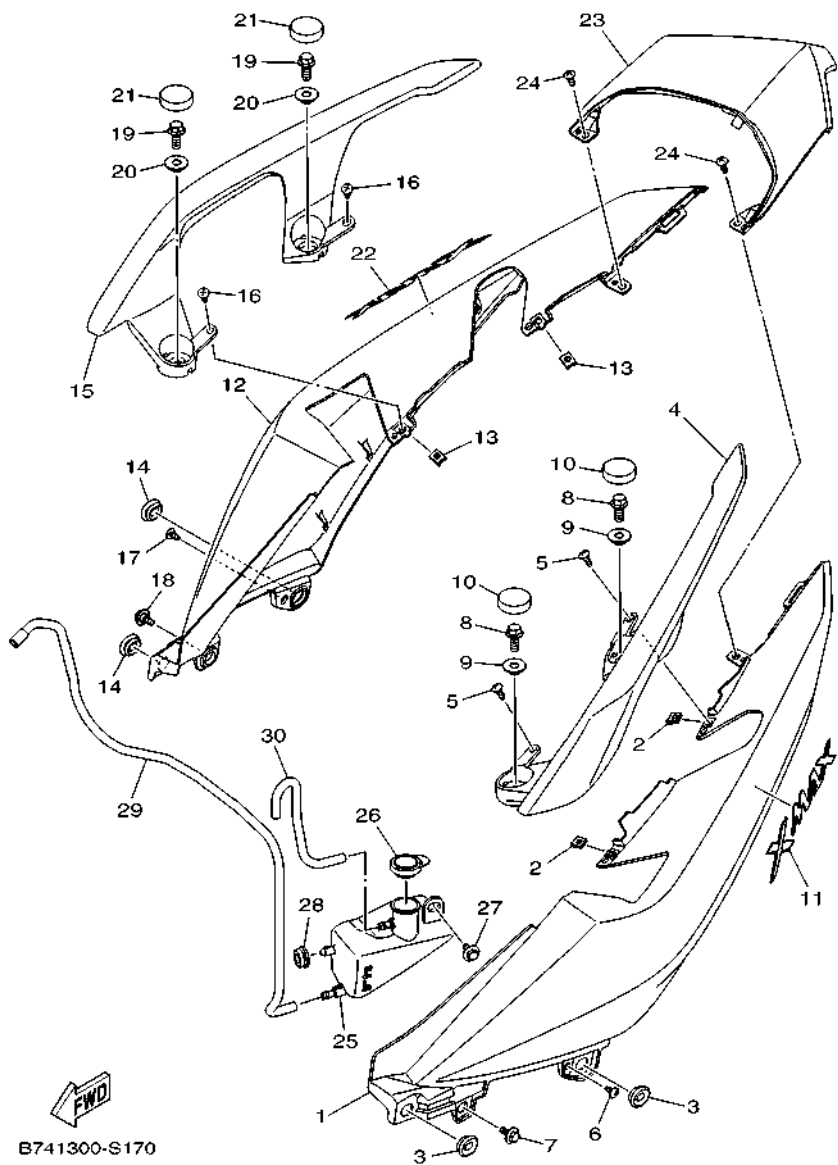
REF. NO.	PART NO.	DESCRIPTION	BU82	REMARKS
1	B74-F1511-00	FENDER, FRONT	1	
2	97702-50012	SCREW, TAPPING	4	
3	90179-06055	NUT	2	
4	B74-F1513-00-P6	STAY, FENDER 1	1	UR FOR MBM3
	B74-F1513-00-P7	STAY, FENDER 1	1	UR FOR MDRM3
5	90183-05807	NUT, SPRING	2	
6	B74-F1514-00-P6	STAY, FENDER 2	1	UR FOR MBM3
	B74-F1514-00-P7	STAY, FENDER 2	1	UR FOR MDRM3
7	90183-05807	NUT, SPRING	2	
8	90109-068A4	BOLT	4	
9	95027-06035	BOLT, FLANGE	2	
10	2DP-F1578-00	EMBLEM	2	
11	B74-F1651-00	COVER, REAR FENDER	1	
12	90183-05807	NUT, SPRING	1	
13	90269-06816	RIVET	4	
14	B74-F172A-00	PANEL 1	1	
15	97702-50012	SCREW, TAPPING	1	
16	90183-05807	NUT, SPRING	2	
17	90109-06887	BOLT	1	
18	B74-F172F-00	PANEL 2	1	
19	97702-50012	SCREW, TAPPING	1	
20	90183-05807	NUT, SPRING	2	
21	90109-06887	BOLT	1	
22	B74-F1611-00	FENDER, REAR	1	
23	90109-06887	BOLT	3	
24	2FC-H5111-00	REFLECTOR, FRONT 1	2	
25	95707-05500	NUT, FLANGE	2	



**FIG. 16 FENDER**

REF. NO.	PART NO.	DESCRIPTION	BU82				REMARKS
26	B74-H4550-00	LICENCE BRACKET ASSY	1				
27	90201-06088	WASHER, PLATE	2				
28	95602-06100	NUT, SELF-LOCKING	2				
29	4G0-21639-00	DAMPER 2	1				
<hr/>							
<hr/>							
<hr/>							
<hr/>							
<hr/>							
<hr/>							
<hr/>							
<hr/>							
<hr/>							
<hr/>							

**FIG. 17 SIDE COVER**

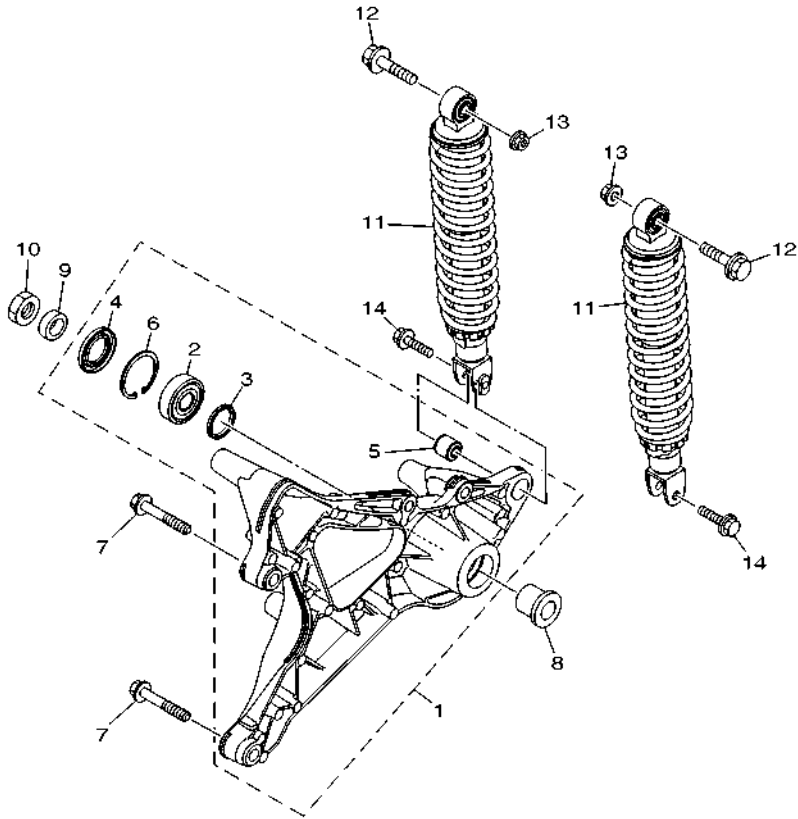


B741300-S170

REF. NO.	PART NO.	DESCRIPTION	BU82		REMARKS
1	B74-F1731-00-P6	COVER, SIDE 3	1		UR FOR MBM3
	B74-F1731-00-P7	COVER, SIDE 3	1		UR FOR MDRM3
2	90183-05807	NUT, SPRING	2		
3	90480-01559	GROMMET	2		
4	B74-F474A-00-P6	ASSIST, GRIP	1		UR FOR MBM3
	B74-F474A-00-P7	ASSIST, GRIP	1		UR FOR MDRM3
5	97702-50016	SCREW, TAPPING	2		
6	97702-50012	SCREW, TAPPING	1		
7	90109-06887	BOLT	1		
8	95812-08020	BOLT, FLANGE	2		
9	90387-08839	COLLAR	2		
10	B74-F3469-00	CAP, BOLT	2		
11	B74-F173B-00	EMBLEM 3D	1		
12	B74-F1741-00-P6	COVER, SIDE 4	1		UR FOR MBM3
	B74-F1741-00-P7	COVER, SIDE 4	1		UR FOR MDRM3
13	90183-05807	NUT, SPRING	2		
14	90480-01559	GROMMET	2		
15	B74-F474W-00-P6	ASSIST,GRIP 2	1		UR FOR MBM3
	B74-F474W-00-P7	ASSIST,GRIP 2	1		UR FOR MDRM3
16	97702-50016	SCREW, TAPPING	2		
17	97702-50012	SCREW, TAPPING	1		
18	90109-06887	BOLT	1		
19	95812-08020	BOLT, FLANGE	2		
20	90387-08839	COLLAR	2		
21	B74-F3469-00	CAP, BOLT	2		
22	B74-F173B-00	EMBLEM 3D	1		
23	B74-F171E-00-P6	COVER, SIDE 5	1		UR FOR MBM3



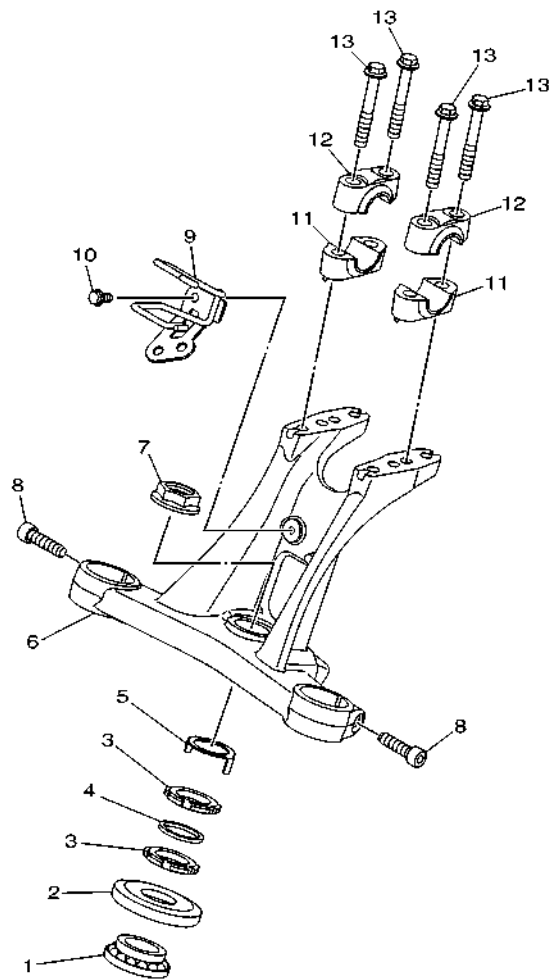
FIG. 18 REAR ARM & SUSPENSION



  
 B741300-S180

REF. NO.	PART NO.	DESCRIPTION	BU82			REMARKS
1	B74-F2100-00	REAR ARM ASSY	1			
2	93306-303YV	.BEARING	1			
3	93106-28801	.OIL SEAL	1			
4	93106-28813	.OIL SEAL	1			
5	5MX-F2216-00	.BUSH, REAR SHOCK ABSORBER	1			
6	99009-47500	.CIRCLIP	1			
7	95812-10060	BOLT, FLANGE	2			
8	B74-F5183-00	COLLAR, WHEEL	1			
9	90387-17807	COLLAR	1			
10	90185-16800	NUT, SELF-LOCKING	1			
11	B74-F2210-00	SHOCK ABSORBER ASSY, REAR	2			
12	95817-10040	BOLT, FLANGE	2			
13	95602-10200	NUT, S/L FLANGE	2			
14	95817-08030	BOLT, FLANGE	2			

**FIG. 19 STEERING**

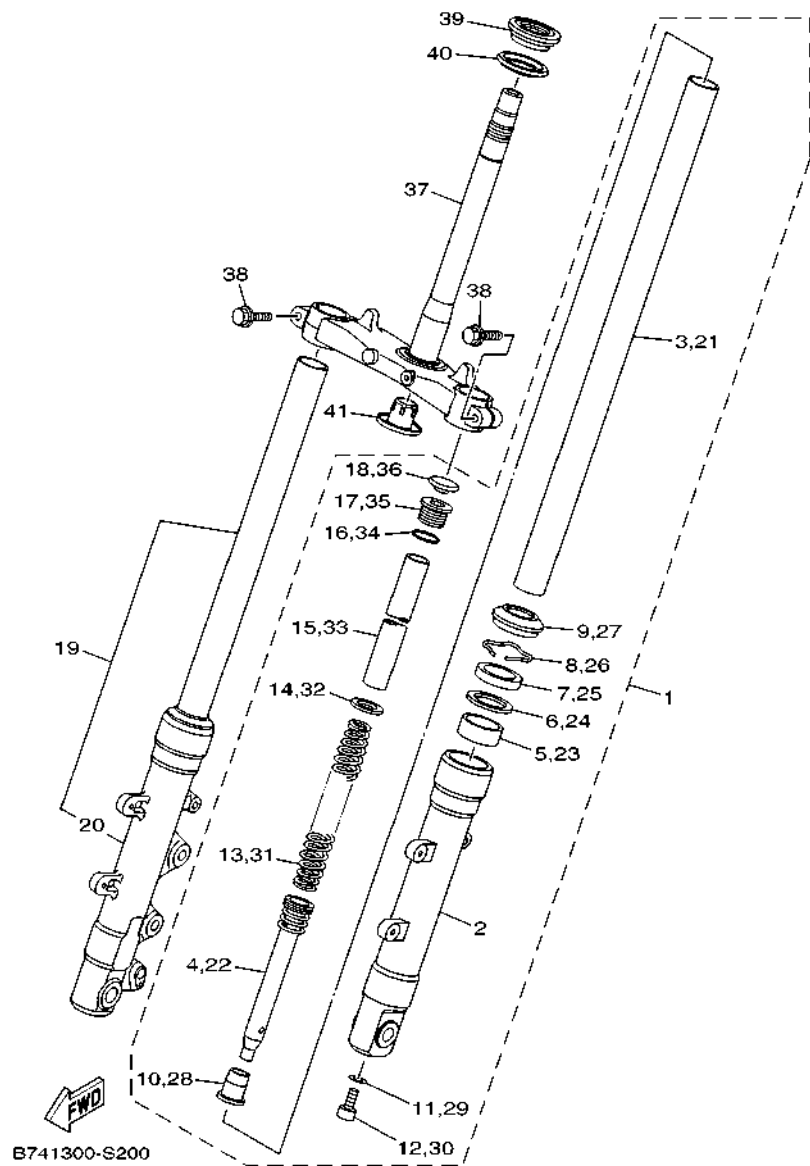


REF. NO.	PART NO.	DESCRIPTION	BU82				REMARKS
1	93399-999Y3	BEARING	1				
2	5BP-F3416-10	COVER, BALL RACE 2	1				
3	90179-25810	NUT	2				
4	90202-26142	WASHER, PLATE	1				
5	5BP-F3418-00	WASHER, SPECIAL	1				
6	B74-F3435-00	CROWN, HANDLE	1				
7	90179-22025	NUT	1				
8	91312-08030	BOLT, HEXAGON SOCKET HEAD	2				
9	B74-F312H-00	CLAMP	1				
10	95022-06012	BOLT, FLANGE	1				
11	B74-F3442-00	HOLDER, HANDLE LOWER	2				
12	B74-F3441-00	HOLDER, HANDLE UPPER	2				
13	95022-08055	BOLT, FLANGE	4				



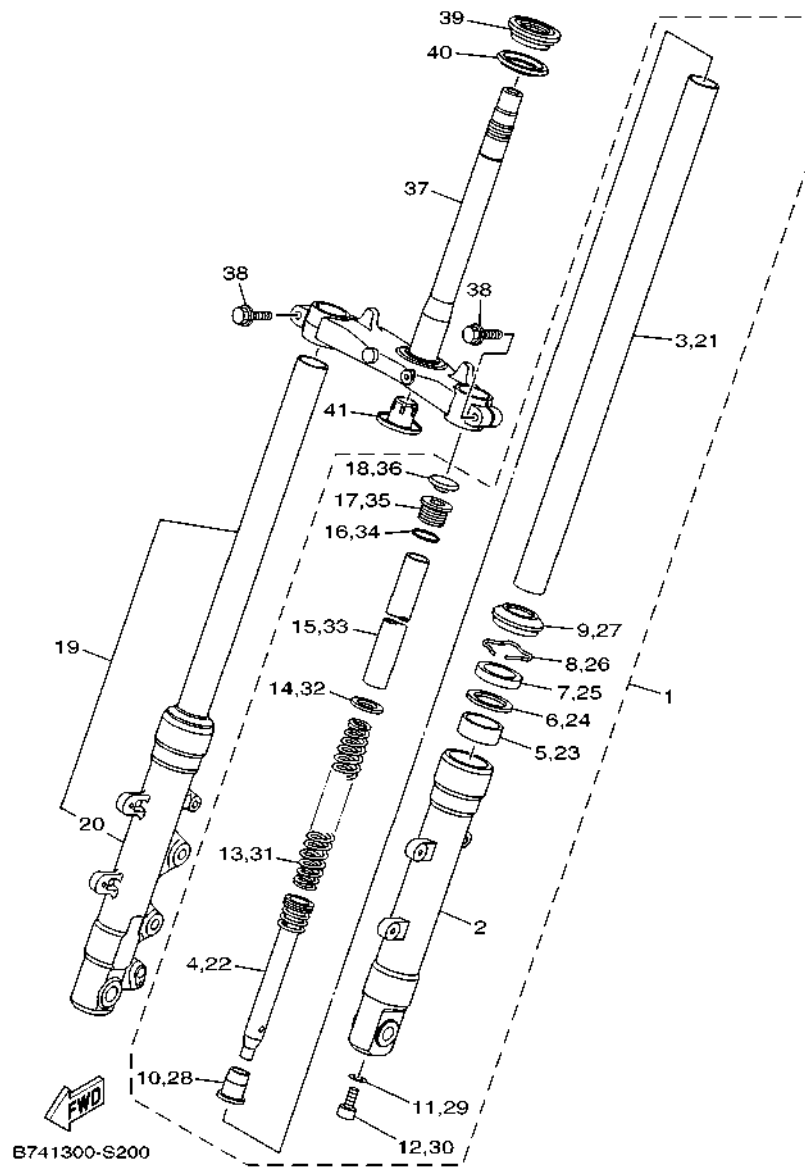
B741300-S190





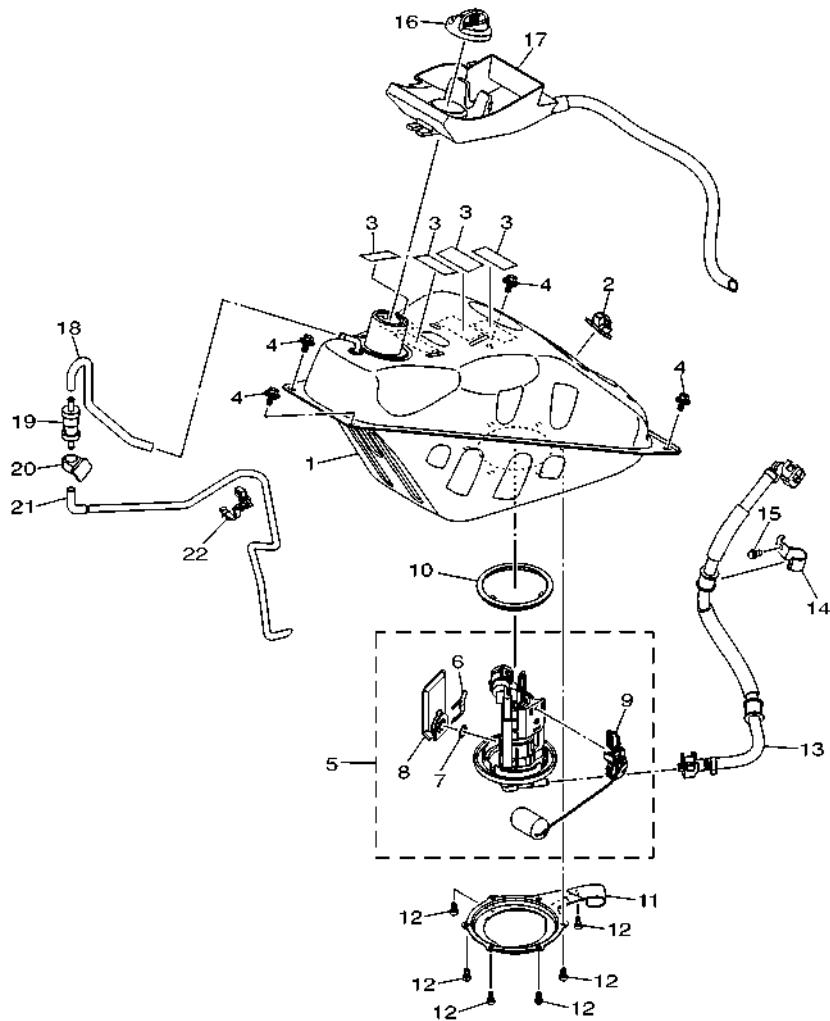
**FIG. 20 FRONT FORK**

REF. NO.	PART NO.	DESCRIPTION	BU82				REMARKS
1	BG6-F3102-00	FRONT FORK ASSY (L.H)	1				
2	B74-F3126-00	.TUBE, OUTER (L.H)	1				
3	BG6-F3107-00	.INNER TUBE COMP.	1				
4	B74-F3170-00	.CYLINDER COMP., FRONT FORK	1				
5	4HC-23125-20	.METAL, SLIDE 1	1				
6	22W-23146-L0	.WASHER, OIL SEAL	1				
7	5BP-F3145-00	.OIL SEAL	1				
8	22W-F3156-L0	.RING, SNAP	1				
9	5BP-F3144-00	.SEAL, DUST	1				
10	2CM-F3166-00	.SPACER, OIL LOCK	1				
11	2BU-F3158-00	.GASKET	1				
12	31B-F3181-00	.BOLT, HEXAGON SOCKET HEAD	1				
13	B74-F3141-00	.SPRING, FRONT FORK	1				
14	2JK-F3149-01	.WASHER, SPRING UPPER	1				
15	B74-F3118-00	.SPACER	1				
16	2JK-F3114-00	.GASKET	1				
17	5BP-F3111-10	.BOLT, CAP	1				
18	2N4-23168-00	.PLUG	1				
19	BG6-F3103-00	FRONT FORK ASSY (R.H)	1				
20	B74-F3136-00	.TUBE, OUTER 2	1				
21	BG6-F3107-00	.INNER TUBE COMP.	1				
22	B74-F3170-00	.CYLINDER COMP., FRONT FORK	1				
23	4HC-23125-20	.METAL, SLIDE 1	1				
24	22W-23146-L0	.WASHER, OIL SEAL	1				
25	5BP-F3145-00	.OIL SEAL	1				
26	22W-F3156-L0	.RING, SNAP	1				
27	5BP-F3144-00	.SEAL, DUST	1				



**FIG. 20 FRONT FORK**

REF. NO.	PART NO.	DESCRIPTION	BU82	REMARKS
28	2CM-F3166-00	.SPACER, OIL LOCK	1	
29	2BU-F3158-00	.GASKET	1	
30	31B-F3181-00	.BOLT, HEXAGON SOCKET HEAD	1	
31	B74-F3141-00	.SPRING, FRONT FORK	1	
32	2JK-F3149-01	.WASHER, SPRING UPPER	1	
33	B74-F3118-00	.SPACER	1	
34	2JK-F3114-00	.GASKET	1	
35	5BP-F3111-10	.BOLT, CAP	1	
36	2N4-23168-00	.PLUG	1	
37	B74-F3340-00	UNDER BRACKET COMP.	1	
38	2JK-F3346-00	BOLT 1	2	
39	93399-99932	BEARING	1	
40	3FV-23462-00	SEAL, STEERING	1	
41	B65-F3123-00	COVER, UNDER 1	1	



BG61460-S210

FIG. 21 FUEL TANK

REF. NO.	PART NO.	DESCRIPTION	BU82				REMARKS
1	B74-F4110-01	FUEL TANK COMP.	1				
2	90464-13185	CLAMP	1				
3	5D9-F414G-00	SEAL	4				
4	90119-068A2	BOLT, WITH WASHER	4				
5	B74-E3907-00	FUEL PUMP COMP.	1				
6	3C1-F4519-00	.CLIP	1				
7	3C1-24512-00	.GASKET	1				
8	3C1-E3915-00	.FILTER	1				
9	B74-H5752-00	.SENDER UNIT ASSY, FUEL METER	1				
10	3C1-F4486-00	O-RING	1				
11	B74-F4425-00	BRACKET, FUEL PUMP 1	1				
12	91312-05010	BOLT, HEXAGON SOCKET HEAD	6				
13	B74-E3971-00	PIPE, FUEL 1	1				
14	B74-F419A-00	HOLDER	1				
15	95022-06012	BOLT, FLANGE	1				
16	B74-F4610-00	CAP ASSY	1				
17	B74-F414A-00	COVER, FILLER	1				
18	B74-F4313-00	PIPE 3	1				
19	1DW-F4180-02	ROLL OVER VALVE ASSY	1				
20	B74-F4135-00	CLAMP 1	1				
21	BG6-F4314-00	PIPE 4	1				
22	90464-10008	CLAMP	1				

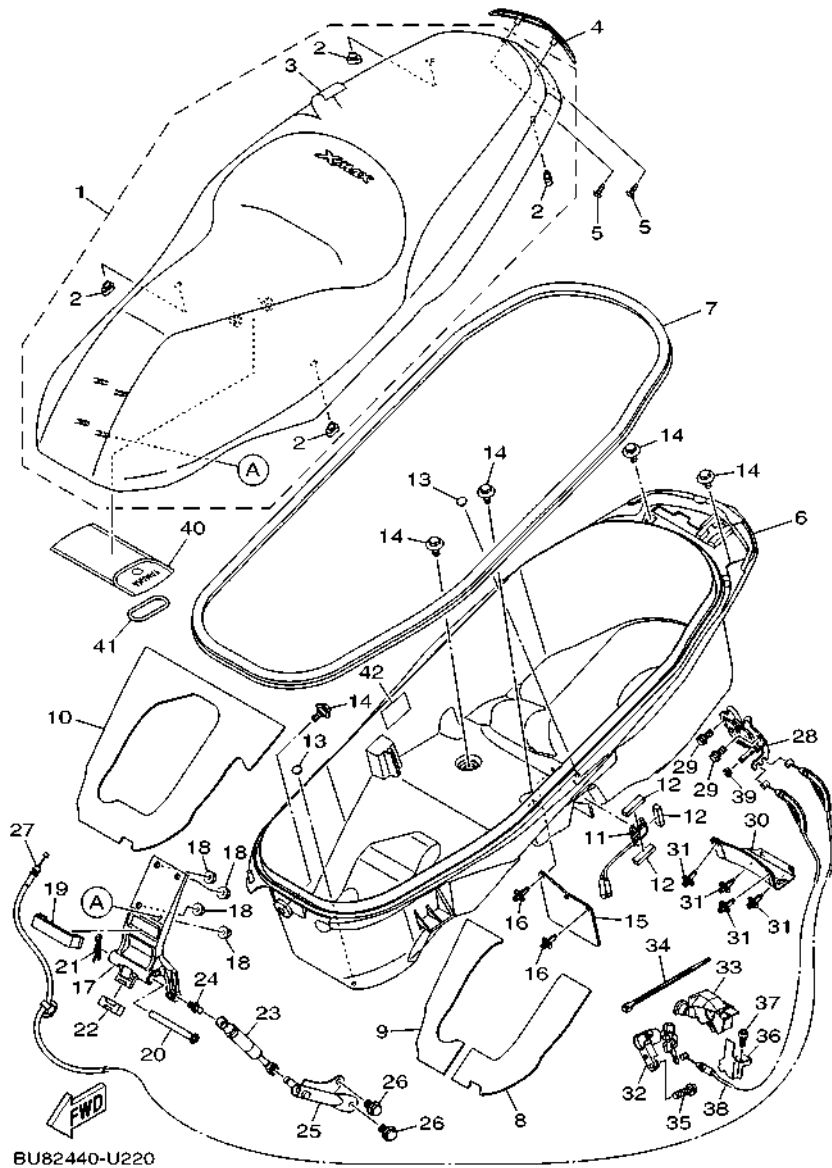


FIG. 22 SEAT

REF. NO.	PART NO.	DESCRIPTION	BU82				REMARKS
1	B74-F4730-00	DOUBLE SEAT ASSY	1				
2	B74-F4741-00	.PAD, SEAT	4				
3	B74-F470F-00	.SEAT COVER COMP.	1				
4	B74-F4786-00	EMBLEM	1				
5	97702-40012	SCREW, TAPPING	2				
6	B74-F473R-00	BOX 1	1				
7	B74-F475M-00	SEAL	1				
8	B74-2476U-00	PROTECTOR 1	1				
9	B74-2476V-00	PROTECTOR,2	1				
10	B74-F4723-00	DAMPER, SEAT	1				
11	B74-H4770-00	LIGHT, ACCESSORY	1				
12	90520-10834	DAMPER, PLATE	3				
13	90338-06809	PLUG	2				
14	90109-06220	BOLT	5				
15	B74-F1621-00	FLAP	1				
16	90269-06816	RIVET	2				
17	B74-F4769-00	HINGE, SEAT	1				
18	95702-06500	NUT, FLANGE	4				
19	B74-F4785-00	MOLE, SEAT	1				
20	B74-F4727-00	PIN, SEAT FITTING	1				
21	90468-18121	CLIP	1				
22	B74-F4639-00	STOPPER, PLATE	1				
23	B74-F478G-00	STOPPER	1				
24	B74-F474E-00	ARM	1				
25	B74-F1121-00	BRACKET, DAMPER	1				
26	95022-08012	BOLT, FLANGE	2				
27	B74-F478E-00	CABLE, SEAT LOCK	1				

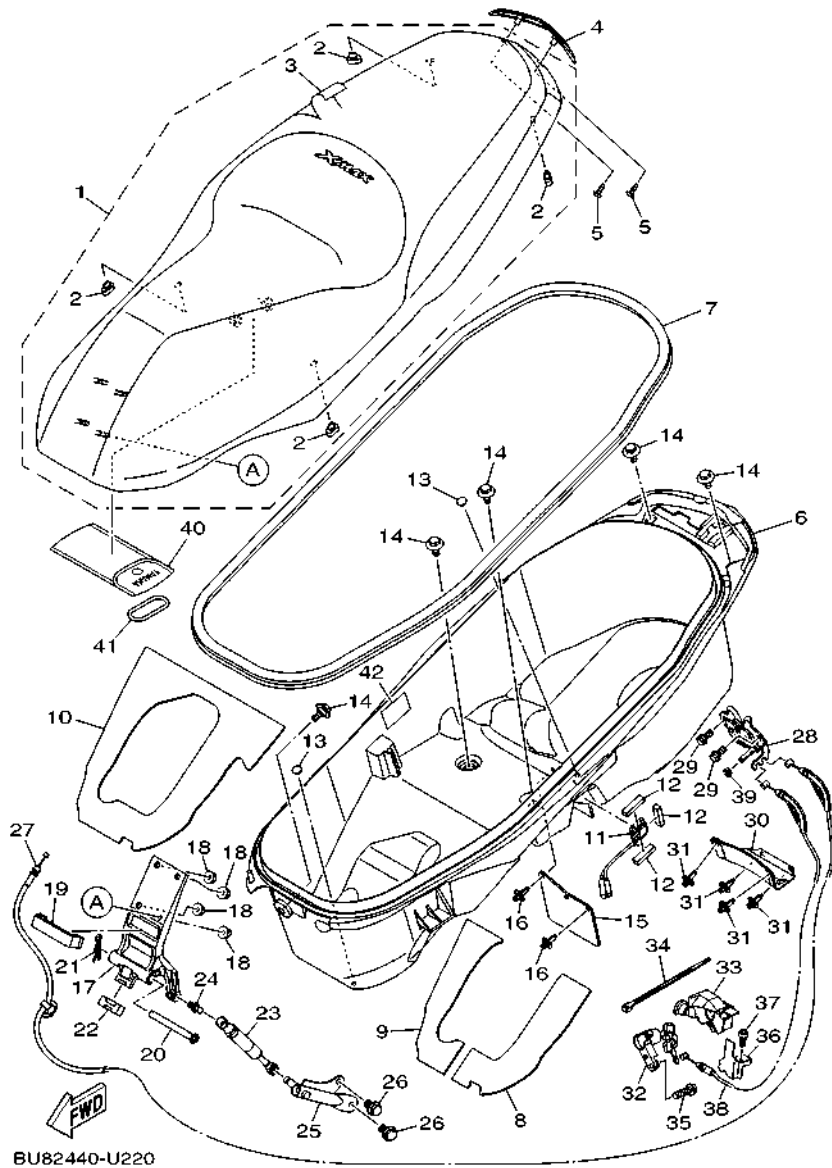
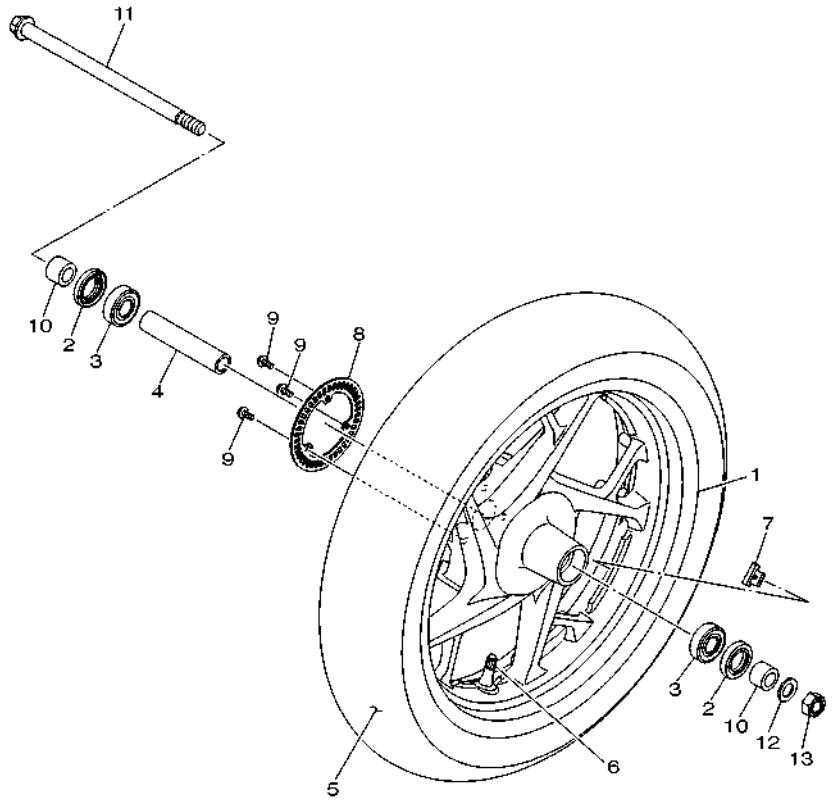


FIG. 22 SEAT

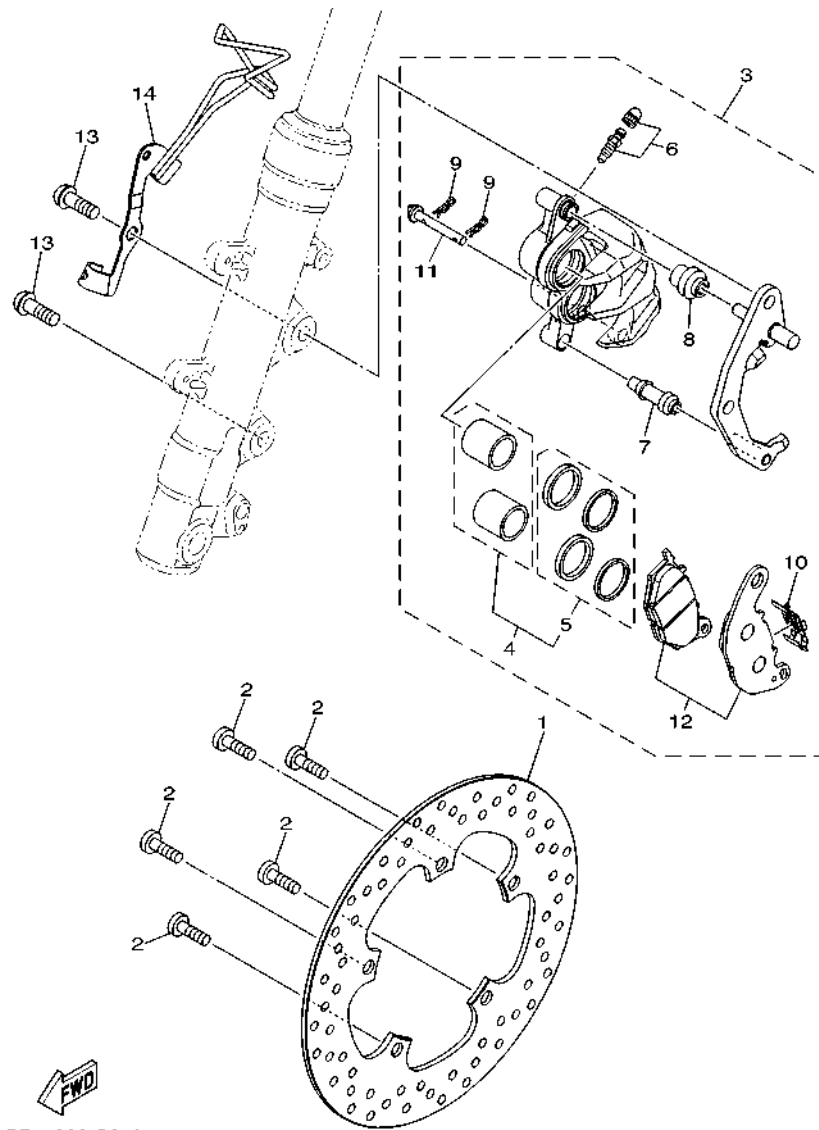
REF. NO.	PART NO.	DESCRIPTION	BU82				REMARKS
28	B65-F4780-00	SEAT LOCK ASSY	1				
29	95022-06012	BOLT, FLANGE	2				
30	B74-F472T-00	COVER, SEAT LOCK	1				
31	90269-06816	RIVET	4				
32	B74-F465E-00	ROTOR COMP.	1				
33	B74-F465B-00	CAP, ROTOR	1				
34	90464-36800	CLAMP	1				
35	92012-06020	BOLT, BUTTON HEAD	1				
36	B74-F471D-00	PLATE, LOCK 1	1				
37	91312-05010	BOLT, HEXAGON SOCKET HEAD	1				
38	B74-F479D-00	WIRE, SEAT LOCK 2	1				
39	1S7-F4768-00	STOPPER	1				
40	B74-F8100-00	TOOL KIT	1				
41	B74-F8175-00	HOLDER, TOOL	1				
42	B17-F1668-00	LABEL, TIRE	1				



**FWD**  
B741300-S230

**FIG. 23 FRONT WHEEL**

REF. NO.	PART NO.	DESCRIPTION	BU82	REMARKS
1	B74-F5168-00-33	CAST WHEEL, FRONT	1	YB FOR MBM3,MDRM3
2	93106-22808	OIL SEAL	2	
3	933A6-202Y1	BEARING	2	
4	90387-15835	COLLAR	1	
5	94112-15800	TIRE (120/70-15 M/C 56P)	1	DUNLOP
6	93900-00828	VALVE, RIM	1	
7	5MT-25398-00	BALANCER, WHEEL (10G)	1	UN
	5MT-25398-10	BALANCER, WHEEL (20G)	1	UN
	5MT-25398-20	BALANCER, WHEEL (30G)	1	UN
8	2DP-F517G-00	ROTOR, SENSOR	1	
9	90149-05029	SCREW	3	
10	90387-15834	COLLAR	2	
11	B74-F5181-00	AXLE, WHEEL	1	
12	90201-15813	WASHER, PLATE	1	
13	90185-14801	NUT, SELF-LOCKING	1	



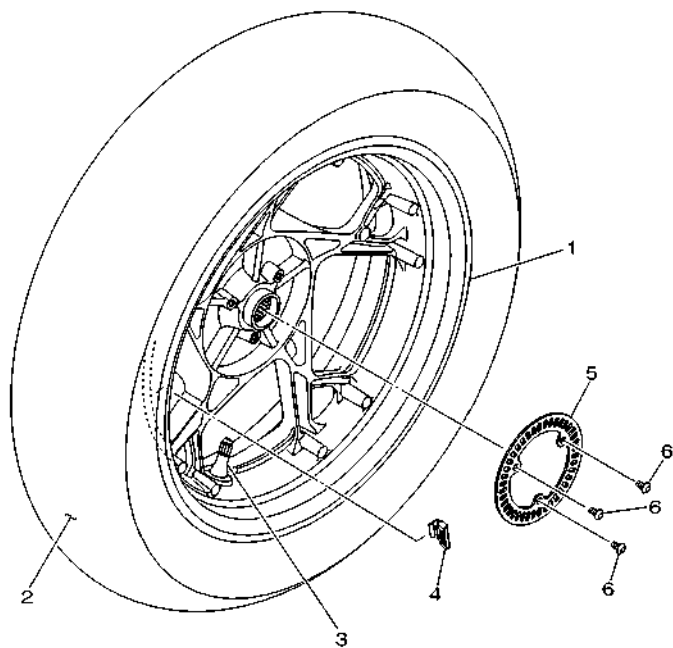
B741300-S240

FIG. 24 FRONT BRAKE CALIPER

REF. NO.	PART NO.	DESCRIPTION	BU82	REMARKS
1	B74-F582U-00	DISK, BRAKE (RIGHT)	1	
2	90109-08232	BOLT	5	
3	B74-F580U-00	CALIPER ASSY (RIGHT)	1	
4	1WD-F5802-00	.PISTON ASSY, CALIPER	1	
5	1WD-F5803-00	..CALIPER SEAL KIT	1	
6	4C9-W0048-00	..BLEED SCREW KIT	1	
7	5YP-F5937-00	..BOOT 2	1	
8	5YP-F5917-00	..BOOT, CALIPER	1	
9	5YP-F5925-01	..CLIP	2	
10	1WD-F5919-00	..SUPPORT, PAD	1	
11	5YP-F5924-00	..PIN, PAD	1	
12	B74-F5805-00	..BRAKE PAD KIT	1	
13	90149-10804	SCREW	2	
14	B74-F3317-00	HOLDER, CABLE	1	

**FIG. 25 REAR WHEEL**

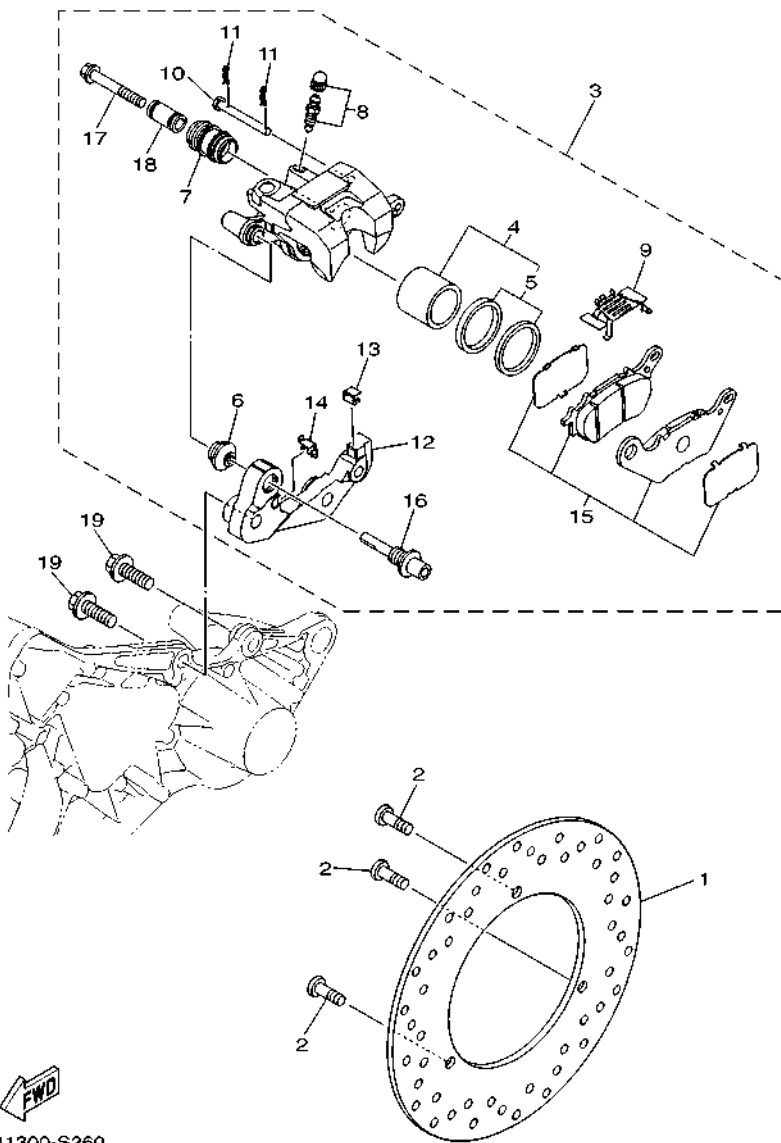
REF. NO.	PART NO.	DESCRIPTION	BU82	REMARKS
1	B74-F5338-00-33	CAST WHEEL, REAR	1	YB FOR MBM3,MDRM3
2	94114-14803	TIRE (140/70-14 M/C 62P)	1	DUNLOP
3	93900-00828	VALVE, RIM	1	
4	5MT-25398-00	BALANCER, WHEEL (10G)	1	UN
	5MT-25398-10	BALANCER, WHEEL (20G)	1	UN
	5MT-25398-20	BALANCER, WHEEL (30G)	1	UN
5	2DP-F517G-00	ROTOR, SENSOR	1	
6	90149-05029	SCREW	3	



B741300-S250

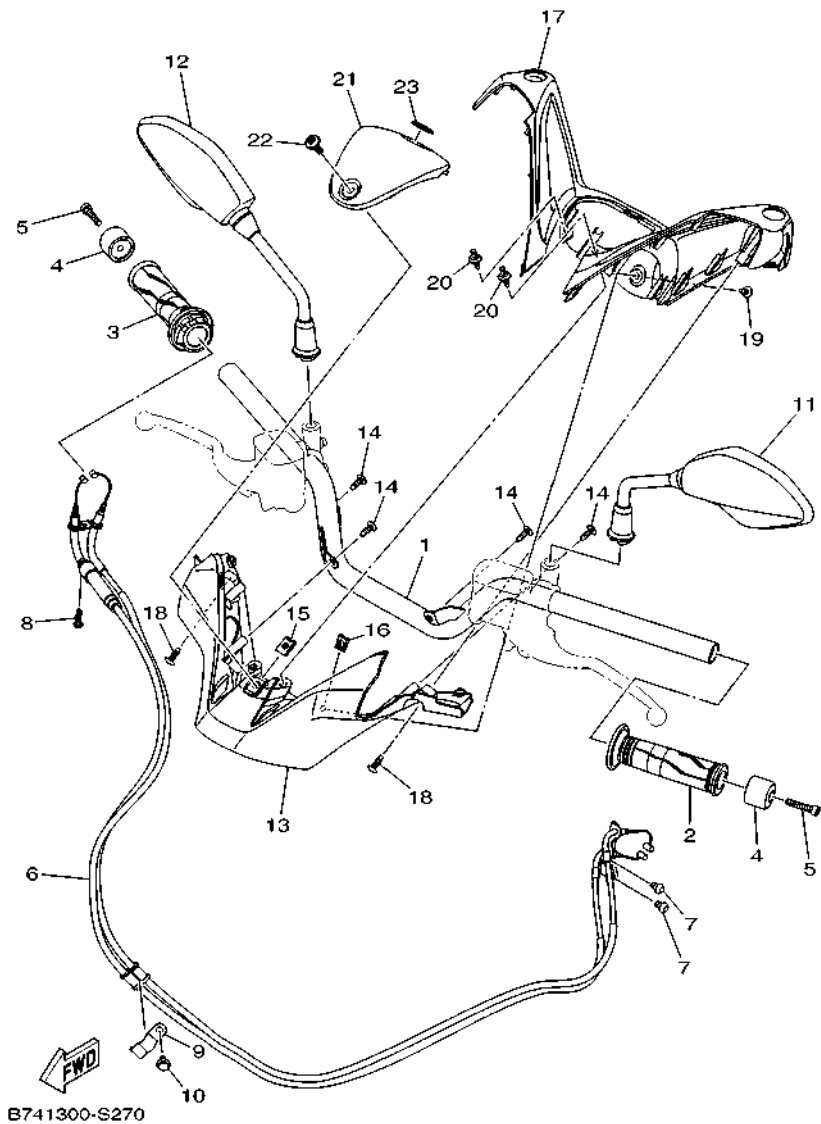


**FIG. 26 REAR BRAKE CALIPER**



B741300-S260

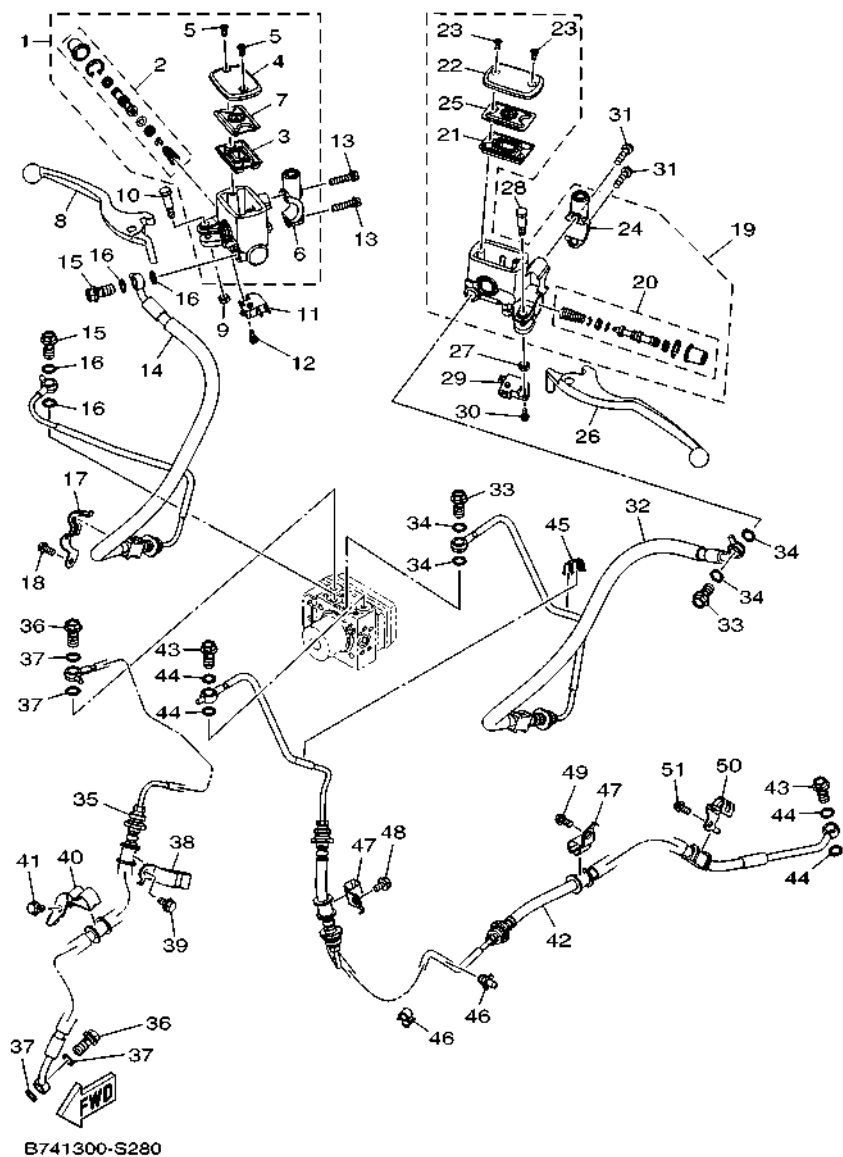
REF. NO.	PART NO.	DESCRIPTION	BU82				REMARKS
1	B74-F582W-00	DISK, REAR BRAKE 2	1				
2	90111-08087	BOLT,HEX. SOCKET BUTTON	3				
3	B74-F580W-00	CALIPER ASSY, REAR 2	1				
4	1WD-F5802-50	.PISTON ASSY, CALIPER	1				
5	1WD-F5803-50	..CALIPER SEAL KIT	1				
6	5YP-F5917-00	.BOOT, CALIPER	1				
7	34X-25937-00	.BOOT 2	1				
8	5YP-W0048-50	.BLEED SCREW KIT	1				
9	B74-F5919-50	.SUPPORT, PAD	1				
10	1WD-F5924-50	.PIN, PAD	1				
11	5YP-F5925-01	.CLIP	2				
12	B74-F5921-50	.BRACKET, SUPPORT	1				
13	1WD-F5939-51	.CLIP, PAD	1				
14	1WD-F5939-61	.CLIP, PAD	1				
15	B74-F5806-00	.BRAKE PAD KIT 2	1				
16	1WD-F5914-50	.PIN, SLIDE	1				
17	5KN-25926-01	.BOLT	1				
18	5TL-F5838-00	.SLEEVE, CALIPER	1				
19	95812-10030	BOLT, FLANGE	2				



**FIG. 27 STEERING HANDLE & CABLE**

REF. NO.	PART NO.	DESCRIPTION	BU82		REMARKS
1	B74-F6110-00	HANDLE COMP.	1		
2	2DP-F6241-00	GRIP	1		
3	2DP-F6240-00	GRIP ASSY	1		
4	1PA-F6246-10	END, GRIP	2		
5	91317-06030	BOLT,HEX.SOCKET HEAD	2		
6	B74-F6301-00	THROTTLE CABLE ASSY	1		
7	92012-06010	BOLT, BUTTON HEAD	2		
8	92017-05016	BOLT, BUTTON HEAD	1		
9	B74-F637G-00	HOLDER, WIRE	1		
10	95022-06012	BOLT, FLANGE	1		
11	B74-F6280-00	REAR VIEW MIRROR ASSY (LEFT)	1		
12	B74-F6290-00	REAR VIEW MIRROR ASSY (RIGHT)	1		
13	B74-F6144-00	COVER, HANDLEBAR LOWER 1	1		
14	97702-50016	SCREW, TAPPING	4		
15	90183-06818	NUT, SPRING	1		
16	90183-05807	NUT, SPRING	1		
17	B74-F6213-00	COVER, UPPER	1		
18	90167-05076	SCREW, TAPPING	2		
19	90160-05808	SCREW, ROUND TAPPING	1		
20	90269-06816	RIVET	2		
21	B74-F6145-00-P0	COVER, HANDLE UPPER 2	1		MBL2
22	90149-06104	SCREW	1		
23	B74-F836B-00	TUNING FORK MARK	1		

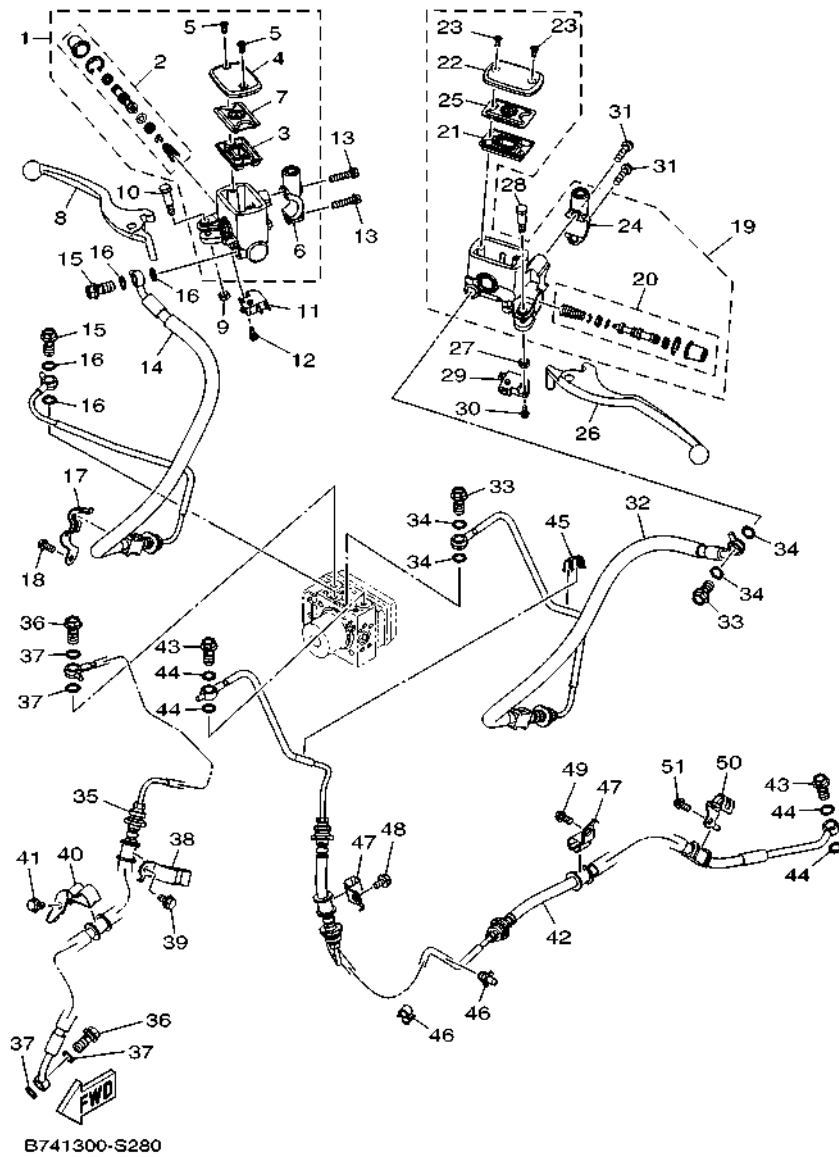
FIG. 28 FRONT MASTER CYLINDER



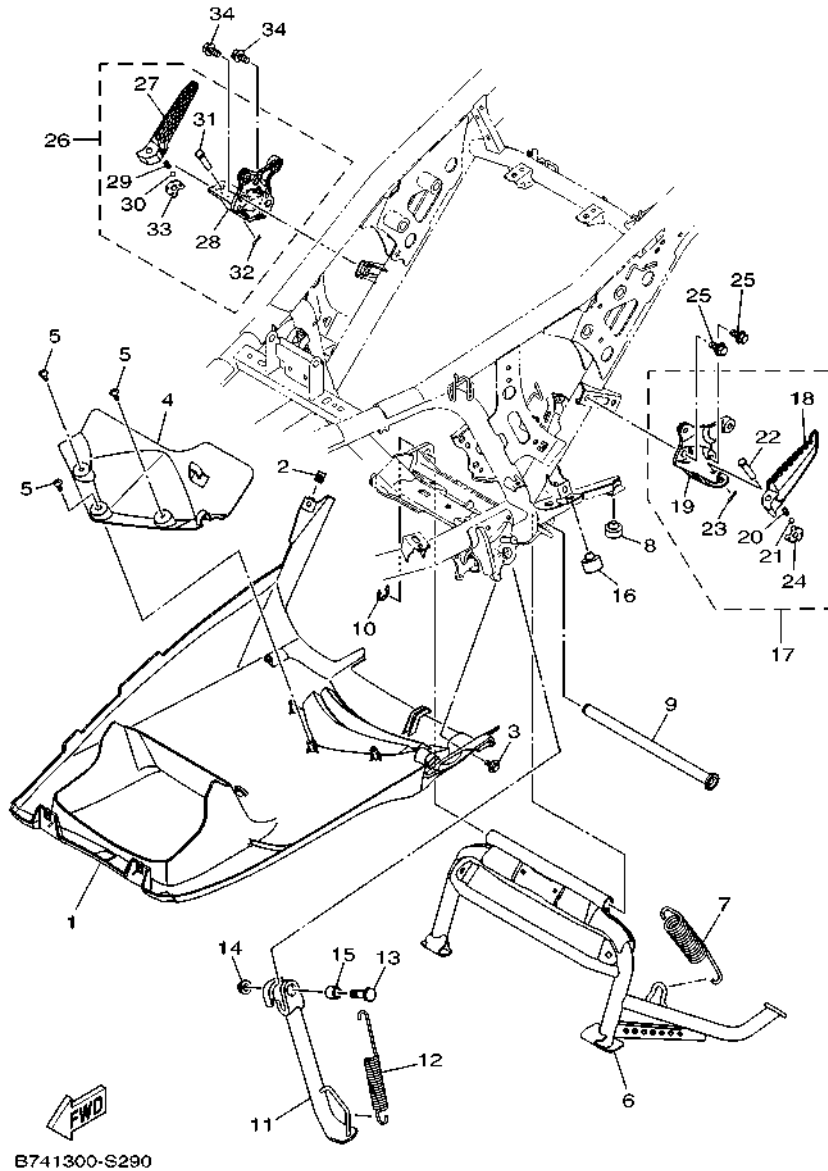
B741300-S280

REF. NO.	PART NO.	DESCRIPTION	BU82	REMARKS
1	B74-F5870-10	MASTER CYLINDER SUB ASSY	1	
2	B74-F5807-00	.CYLINDER KIT, MASTER	1	
3	5RB-25854-00	.DIAPHRAGM, RESERVOIR	1	
4	1WD-F5852-00	.CAP, RESERVOIR	1	
5	36Y-2589H-00	.SCREW	2	
6	B74-F5867-00	.BRACKET, MASTER CYLINDER	1	
7	3C1-F5855-00	.BUSH,DIAPHRAGM	1	
8	B74-H3922-00	LEVER 2	1	
9	95602-06100	NUT, SELF-LOCKING	1	
10	90109-06577	BOLT	1	
11	2DP-H3980-00	FRONT STOP SWITCH ASSY	1	
12	97602-04212	SCREW, PAN HEAD WITH WASHER	1	
13	95027-06025	BOLT, FLANGE	2	
14	B74-F5872-00	HOSE, BRAKE 1	1	
15	90401-10812	BOLT, UNION	2	
16	90201-10118	WASHER, PLATE	4	
17	B74-F5886-00	HOLDER, BRAKE HOSE	1	
18	95022-06012	BOLT, FLANGE	1	
19	B74-F5870-00	MASTER CYLINDER SUB ASSY	1	
20	B74-F5807-00	.CYLINDER KIT, MASTER	1	
21	5RB-25854-00	.DIAPHRAGM, RESERVOIR	1	
22	1WD-F5852-00	.CAP, RESERVOIR	1	
23	36Y-2589H-00	.SCREW	2	
24	B74-F5867-00	.BRACKET, MASTER CYLINDER	1	
25	3C1-F5855-00	.BUSH,DIAPHRAGM	1	
26	B74-H3912-00	LEVER 1	1	
27	95602-06100	NUT, SELF-LOCKING	1	

**FIG. 28 FRONT MASTER CYLINDER**



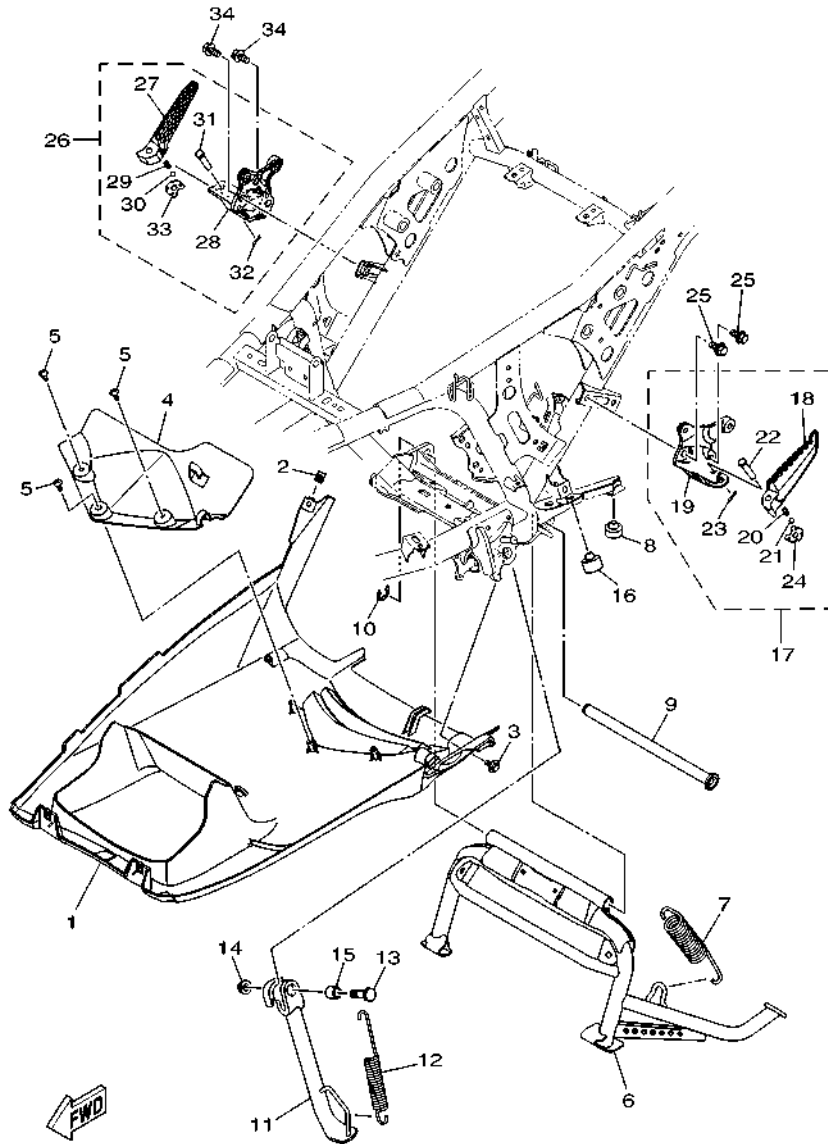
REF. NO.	PART NO.	DESCRIPTION	BU82				REMARKS
28	90109-06577	BOLT	1				
29	2DP-H2530-00	STOP SWITCH ASSY	1				
30	97602-04212	SCREW, PAN HEAD WITH WASHER	1				
31	95027-06025	BOLT, FLANGE	2				
32	B74-F5873-00	HOSE, BRAKE 2	1				
33	90401-10812	BOLT, UNION	2				
34	90201-10118	WASHER, PLATE	4				
35	B74-F5874-00	HOSE, BRAKE	1				
36	90401-10812	BOLT, UNION	2				
37	90201-10118	WASHER, PLATE	4				
38	B74-F5875-00	HOLDER, BRAKE HOSE 1	1				
39	95807-06012	BOLT, FLANGE	1				
40	B74-F5887-00	HOLDER, BRAKE HOSE	1				
41	95807-06012	BOLT, FLANGE	1				
42	B74-F581J-00	HOSE, BRAKE 4	1				
43	90401-10812	BOLT, UNION	2				
44	90201-10118	WASHER, PLATE	4				
45	90464-06008	CLAMP	1				
46	90464-07805	CLAMP	2				
47	B74-F5876-00	HOLDER, BRAKE HOSE 2	2				
48	95807-06010	BOLT, FLANGE	1				
49	95802-06012	BOLT, FLANGE	1				
50	B74-F587A-00	HOLDER, BRAKE HOSE	1				
51	95802-06012	BOLT, FLANGE	1				



B741300-S290

FIG. 29 STAND & FOOTREST

REF. NO.	PART NO.	DESCRIPTION	BU82				REMARKS
1	B74-F8385-00	COVER, UNDER	1				
2	90183-05807	NUT, SPRING	1				
3	90109-06887	BOLT	1				
4	B74-F838N-00	DUCT 1	1				
5	97702-50016	SCREW, TAPPING	3				
6	B74-F7111-00	STAND, MAIN	1				
7	90506-40805	SPRING, TENSION	1				
8	45P-F7114-00	STOPPER, MAIN STAND	1				
9	B74-F7261-00	SHAFT	1				
10	93430-12809	CIRCLIP	1				
11	B74-F7311-00	STAND, SIDE	1				
12	90506-32813	SPRING, TENSION	1				
13	90101-10830	BOLT	1				
14	95602-10200	NUT, S/L FLANGE	1				
15	90387-10849	COLLAR	1				
16	4YY-F7114-00	STOPPER, MAIN STAND	1				
17	B74-F7430-00	REAR FOOTREST ASSY 1	1				
18	2DP-F7431-01	.FOOTREST, REAR 1	1				
19	B74-F741L-00	.BRACKET 4	1				
20	90501-12743	.SPRING, COMPRESSION	1				
21	93501-04830	.BALL	1				
22	91702-08038	.PIN, CLEVIS	1				
23	91402-25015	.PIN, COTTER	1				
24	B74-F7437-00	.WASHER, SPECIAL	1				
25	95812-08016	BOLT, FLANGE	2				
26	B74-F7440-00	REAR FOOTREST ASSY 2	1				
27	2DP-F7441-01	.FOOTREST, REAR 2	1				

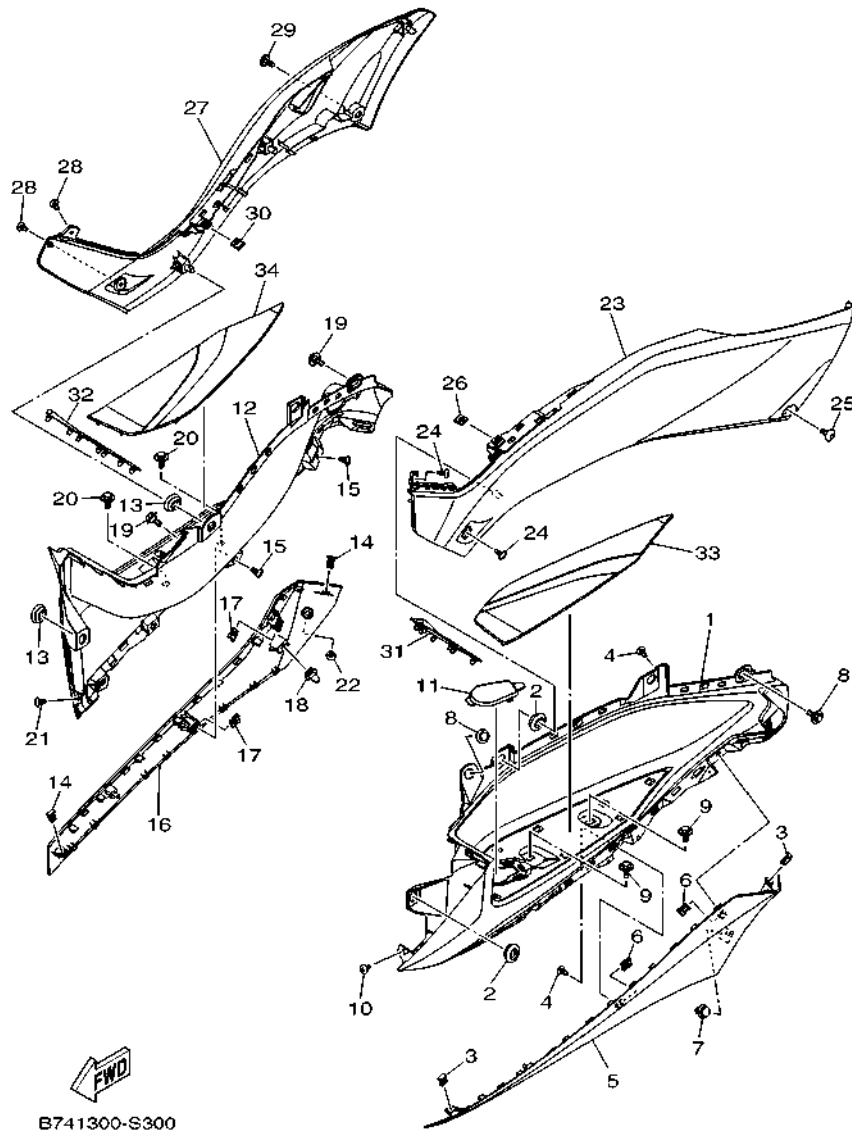


B741300-S290

FIG. 29 STAND & FOOTREST

REF. NO.	PART NO.	DESCRIPTION	BU82				REMARKS
28	B74-F742L-00	.BRACKET 5	1				
29	90501-12743	.SPRING, COMPRESSION	1				
30	93501-04830	.BALL	1				
31	91702-08038	.PIN, CLEVIS	1				
32	91402-25015	.PIN, COTTER	1				
33	B74-F7437-00	.WASHER, SPECIAL	1				
34	95812-08016	BOLT, FLANGE	2				

**FIG. 30 STAND & FOOTREST 2**



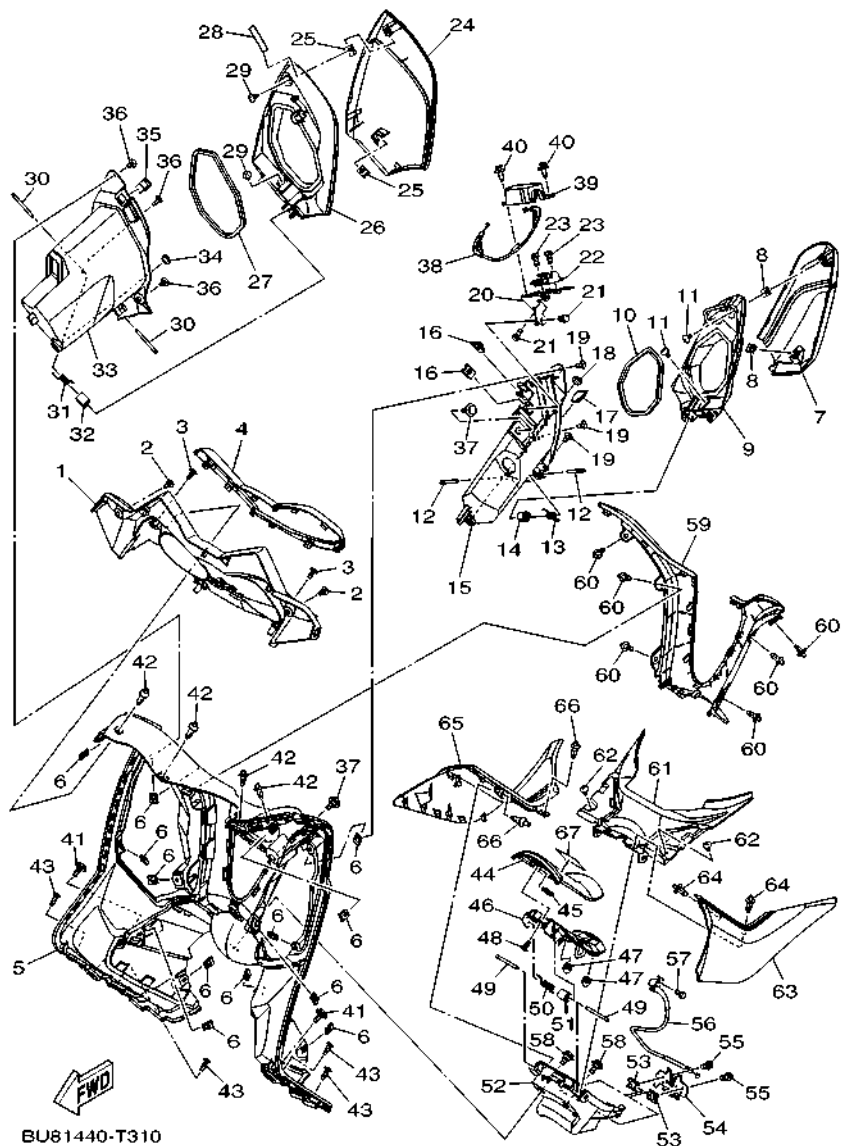
B741300-S300

REF. NO.	PART NO.	DESCRIPTION	BU82	REMARKS
1	B74-F7481-00	BOARD, FOOTREST	1	
2	90480-01559	GROMMET	2	
3	90464-04004	CLAMP	2	
4	97702-50012	SCREW, TAPPING	2	
5	B74-F171L-00-P6	MOLE, SIDE COVER 1	1	UR FOR MBM3
	B74-F171L-00-P7	MOLE, SIDE COVER 1	1	UR FOR MDRM3
6	90183-05807	NUT, SPRING	2	
7	90269-09005	RIVET	1	
8	90109-06887	BOLT	2	
9	90119-06051	BOLT, WITH WASHER	2	
10	97702-50012	SCREW, TAPPING	1	
11	2DP-F172W-00	COVER	1	
12	B74-F7488-00	BOARD, FOOTREST 2	1	
13	90480-01559	GROMMET	2	
14	90464-04004	CLAMP	2	
15	97702-50012	SCREW, TAPPING	2	
16	B74-F171M-00-P6	MOLE, SIDE COVER 2	1	UR FOR MBM3
	B74-F171M-00-P7	MOLE, SIDE COVER 2	1	UR FOR MDRM3
17	90183-05807	NUT, SPRING	2	
18	90269-09005	RIVET	1	
19	90109-06887	BOLT	2	
20	90119-06051	BOLT, WITH WASHER	2	
21	97702-50012	SCREW, TAPPING	1	
22	90160-05808	SCREW, ROUND TAPPING	1	
23	B74-F1711-00-P0	COVER, SIDE 1	1	MBL2
24	90160-05808	SCREW, ROUND TAPPING	2	
25	90111-06839	BOLT, HEX. SOCKET BUTTON	1	





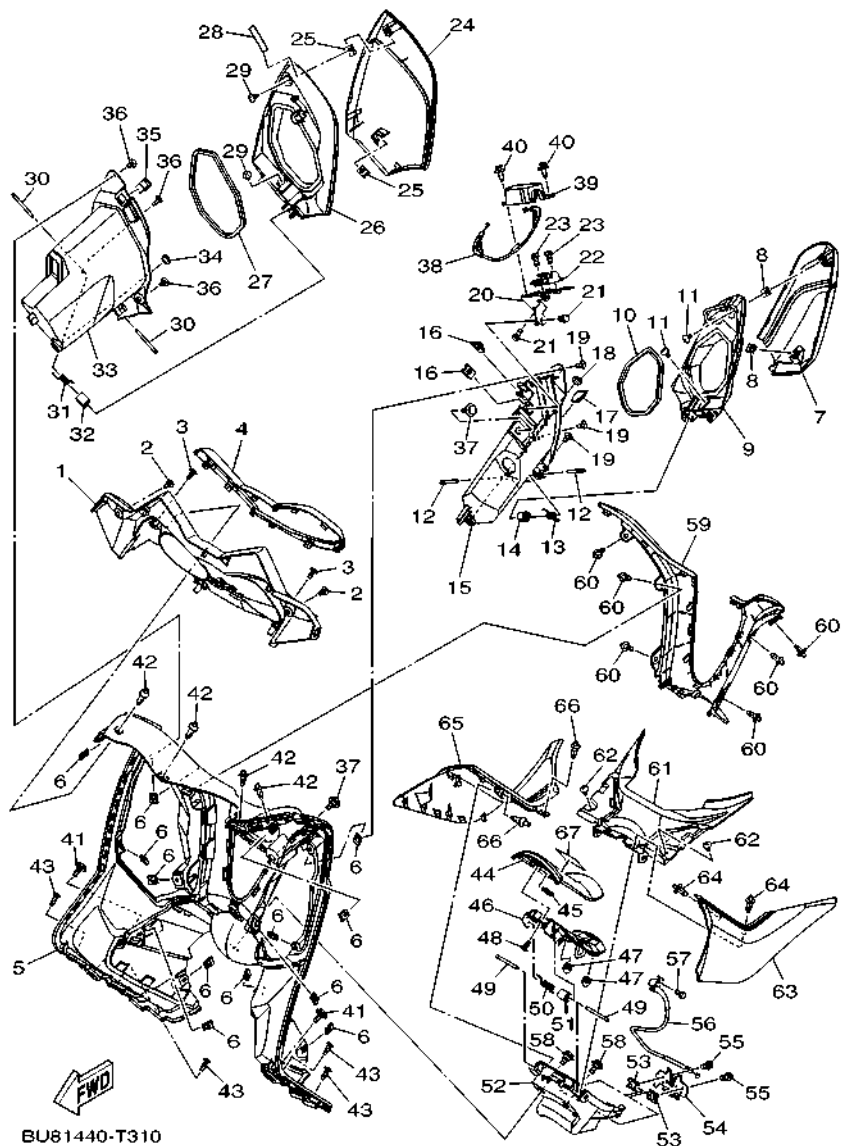
FIG. 31 LEG SHIELD



BU81440-T310

REF. NO.	PART NO.	DESCRIPTION	BU82	REMARKS
1	B74-F836K-00	PANEL, INNER 1	1	
2	90160-05808	SCREW, ROUND TAPPING	2	
3	97702-50012	SCREW, TAPPING	2	
4	B74-F8346-00-P0	MOLE 2	1	MBL2
5	B74-F8311-00	LEG SHIELD 1	1	
6	90183-05807	NUT, SPRING	12	
7	B74-F836L-00	PANEL, INNER 2	1	
8	90183-05807	NUT, SPRING	2	
9	B74-F839L-00	LID 2	1	
10	90520-06808	DAMPER, PLATE	1	
11	97707-50012	SCREW, TRUSS HEAD TAPPING	2	
12	B74-F818A-00	PIN	2	
13	90508-13800	SPRING, TORSION	1	
14	B74-F834F-00	DAMPER	1	
15	B74-F838L-00	BOX 2	1	
16	90183-06818	NUT, SPRING	2	
17	B74-F8349-00	CAP	1	
18	4US-F6199-00	PLUG, BLIND	1	
19	97707-50012	SCREW, TRUSS HEAD TAPPING	3	
20	B74-F8357-00	STAY 2	1	
21	95022-06012	BOLT, FLANGE	2	
22	1DY-F4780-00	SEAT LOCK ASSY	1	
23	95022-06012	BOLT, FLANGE	2	
24	B74-F836M-00	PANEL, INNER 3	1	
25	90183-05807	NUT, SPRING	2	
26	B74-F839V-00	LID 3	1	
27	90520-06808	DAMPER, PLATE	1	

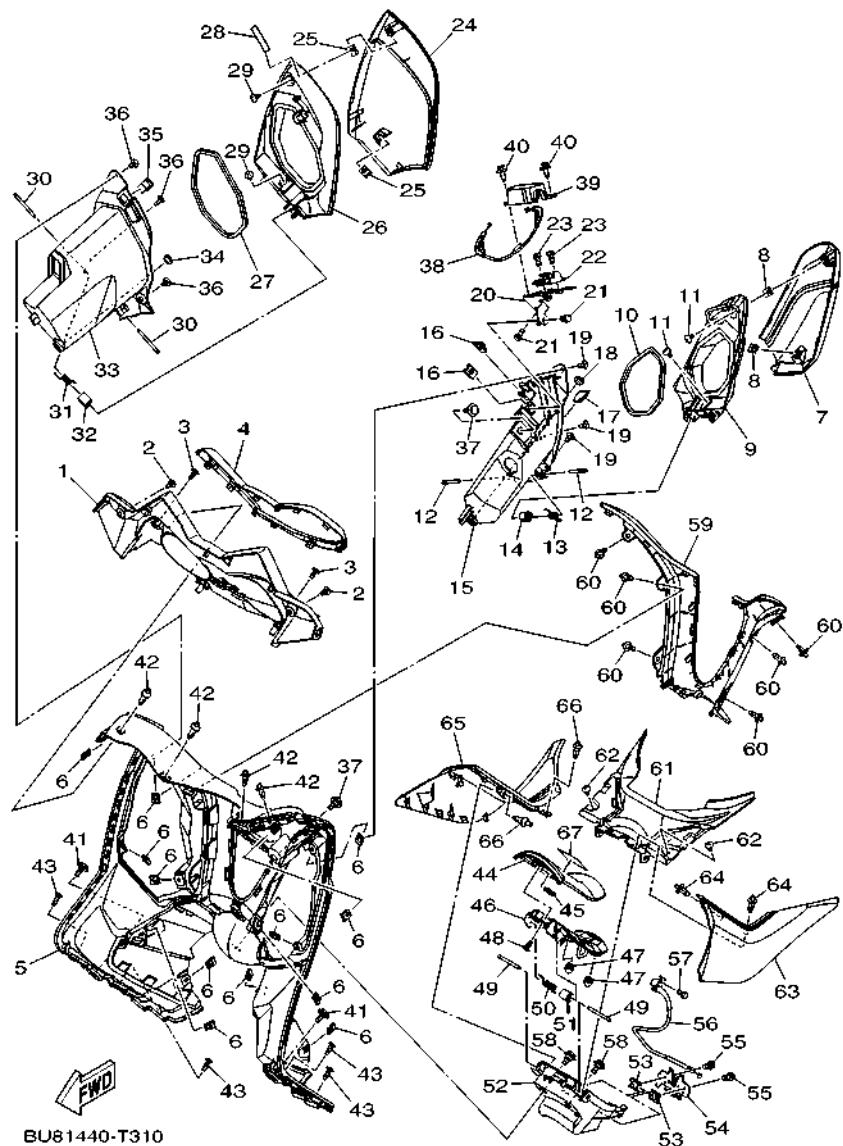
FIG. 31 LEG SHIELD



BU81440-T310

REF. NO.	PART NO.	DESCRIPTION	BU82	REMARKS
28	B74-F8336-00	PLATE	1	
29	97707-50012	SCREW, TRUSS HEAD TAPPING	2	
30	B74-F818A-00	PIN	2	
31	90508-13801	SPRING, TORSION	1	
32	B74-F834F-00	DAMPER	1	
33	B74-F838V-00	BOX 3	1	
34	4US-F6199-00	PLUG, BLIND	1	
35	90464-13801	CLAMP	1	
36	97707-50012	SCREW, TRUSS HEAD TAPPING	3	
37	90109-06887	BOLT	2	
38	B74-F835X-00	WIRE	1	
39	B74-F8365-00	COVER	1	
40	90269-06812	RIVET	2	
41	90119-06051	BOLT, WITH WASHER	2	
42	90269-06816	RIVET	4	
43	97702-50016	SCREW, TAPPING	4	
44	B74-F74A8-00-P0	LID, FUEL	1	MBL2
45	90183-05807	NUT, SPRING	1	
46	B74-F839W-00	LID 4	1	
47	4G0-21639-00	DAMPER 2	2	
48	97702-50012	SCREW, TAPPING	1	
49	B74-F818A-00	PIN	2	
50	90508-14803	SPRING, TORSION	1	
51	B74-F834F-00	DAMPER	1	
52	B74-F838W-00	BOX 4	1	
53	90183-06818	NUT, SPRING	2	
54	1DY-F4780-00	SEAT LOCK ASSY	1	

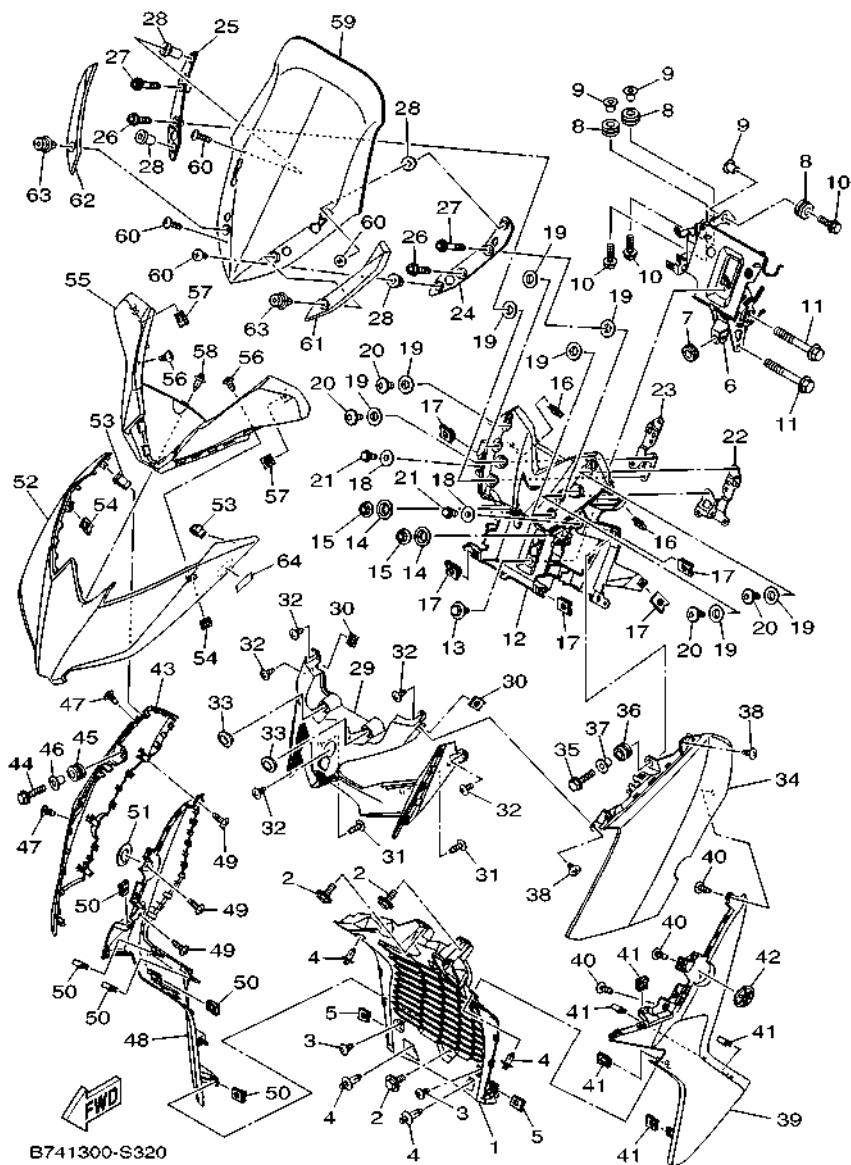
FIG. 31 LEG SHIELD



BU81440-T310

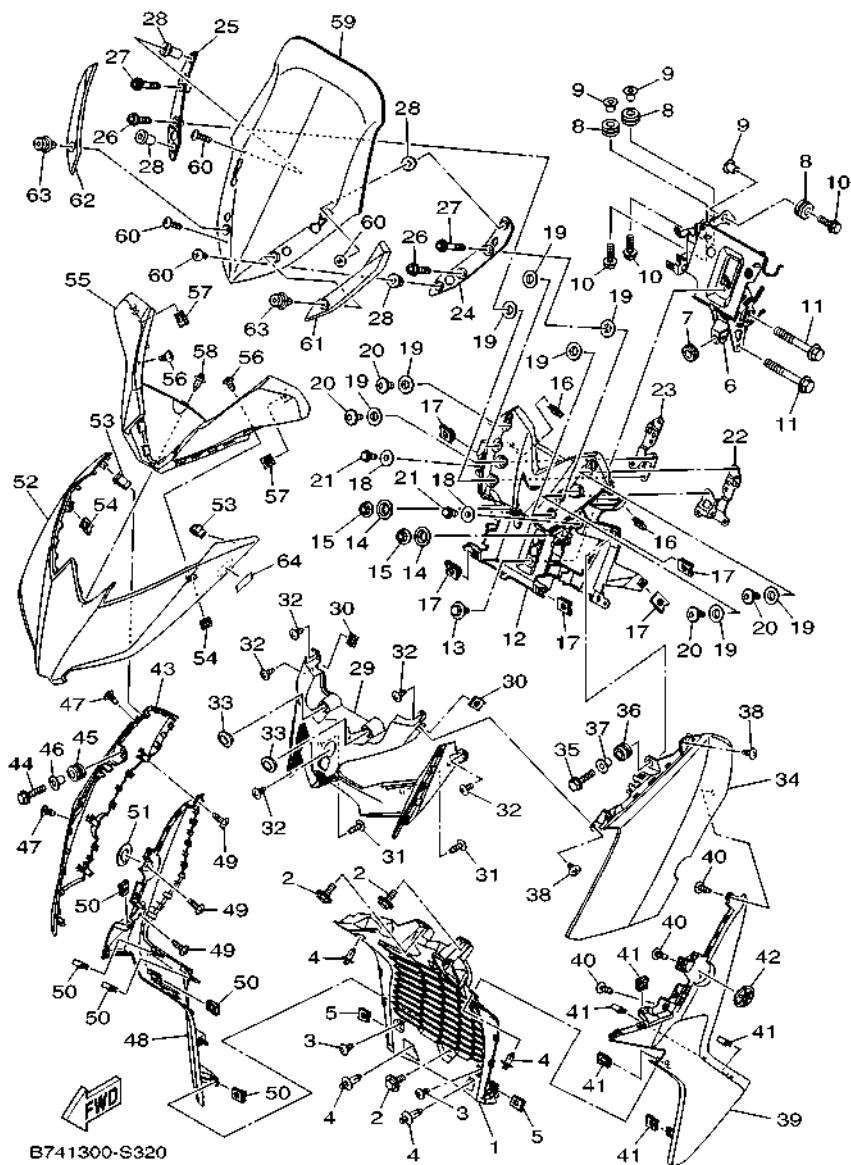
REF. NO.	PART NO.	DESCRIPTION	BU82	REMARKS
55	95022-06012	BOLT, FLANGE	2	
56	B74-F4494-00	WIRE, PULL	1	
57	97527-05512	BOLT, WITH WASHER	1	
58	90109-06220	BOLT	2	
59	B74-F8312-00-P0	LEG SHIELD 2	1	MBL2
60	90269-06816	RIVET	6	
61	B74-F842M-00	COVER 1	1	
62	97702-50012	SCREW, TAPPING	2	
63	B74-F837L-00	PANEL, CONSOLE 1	1	
64	90269-06816	RIVET	2	
65	B74-F837M-00	PANEL, CONSOLE 2	1	
66	90269-06816	RIVET	2	
67	BU8-F1568-00	LABEL, WARNING	1	

FIG. 32 WINDSHIELD



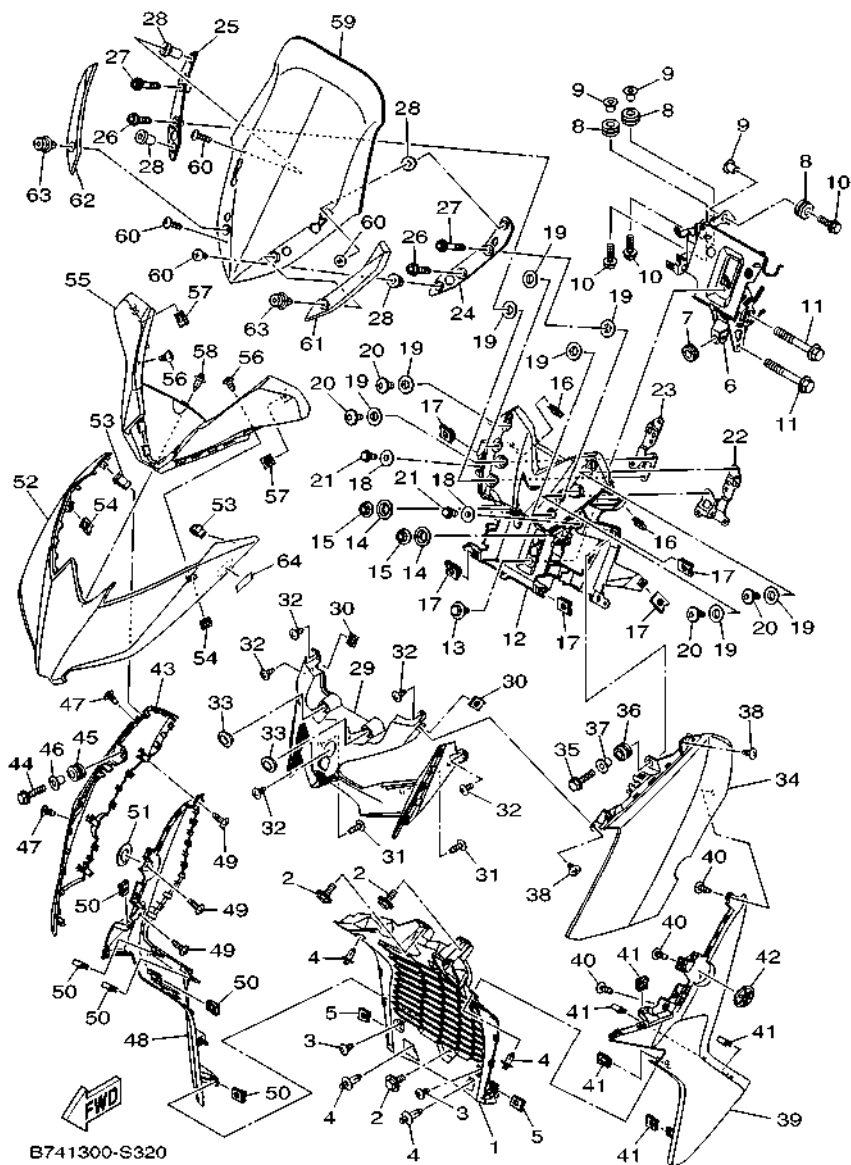
REF. NO.	PART NO.	DESCRIPTION	BU82	REMARKS
1	B74-F837N-00	GRILL, AIR INTAKE 1	1	
2	90119-06051	BOLT, WITH WASHER	3	
3	90160-05808	SCREW, ROUND TAPPING	2	
4	90269-06816	RIVET	4	
5	90183-05807	NUT, SPRING	2	
6	B74-F8321-00	STAY 1	1	
7	90480-10289	GROMMET	1	
8	90480-14229	GROMMET	3	
9	90387-068N8	COLLAR	3	
10	95802-06020	BOLT, FLANGE	3	
11	95812-08055	BOLT, FLANGE	2	
12	B74-H212B-00	BOX, BATTERY 1	1	
13	90109-06887	BOLT	1	
14	90387-09805	COLLAR	2	
15	90179-06841	NUT	2	
16	90183-05807	NUT, SPRING	2	
17	90183-06818	NUT, SPRING	5	
18	90387-06048	COLLAR	2	
19	90387-09808	COLLAR	8	
20	90111-06839	BOLT,HEX. SOCKET BUTTON	4	
21	95022-06012	BOLT, FLANGE	2	
22	B74-F8306-00	PLATE, WINDSHIELD	1	
23	B74-F835P-00	PLATE, WINDSHIELD 2	1	
24	B74-F8322-00	STAY 2	1	
25	B74-F8332-00	STAY, LEG SHIELD	1	
26	90110-06380	BOLT, HEXAGON SOCKET HEAD	2	
27	90109-06009	BOLT	2	

FIG. 32 WINDSHIELD



REF. NO.	PART NO.	DESCRIPTION	BU82	REMARKS
28	90179-05003	NUT	4	
29	B74-F286F-00	COVER, FRONT 2	1	
30	90183-05807	NUT, SPRING	2	
31	97702-50016	SCREW, TAPPING	2	
32	97702-50012	SCREW, TAPPING	5	
33	90480-01558	GROMMET	2	
34	B74-F8351-00-P6	BODY, COWLING	1	UR FOR MBM3
	B74-F8351-00-P7	BODY, COWLING	1	UR FOR MDRM3
35	95802-06025	BOLT, FLANGE	1	
36	90480-14023	GROMMET	1	
37	90387-06158	COLLAR	1	
38	97702-50012	SCREW, TAPPING	2	
39	B74-F835J-00-P0	BODY, FRONT UNDER 1	1	MBL2
40	97702-50016	SCREW, TAPPING	3	
41	90183-05807	NUT, SPRING	5	
42	B74-F414B-00	EMBLEM	1	
43	B74-F8377-00-P6	BODY, COWLING 2	1	UR FOR MBM3
	B74-F8377-00-P7	BODY, COWLING 2	1	UR FOR MDRM3
44	95802-06025	BOLT, FLANGE	1	
45	90480-14023	GROMMET	1	
46	90387-06158	COLLAR	1	
47	97702-50012	SCREW, TAPPING	2	
48	B74-F835K-00-P0	BODY, FRONT UNDER 2	1	MBL2
49	97702-50016	SCREW, TAPPING	3	
50	90183-05807	NUT, SPRING	5	
51	B74-F414B-00	EMBLEM	1	
52	B74-F2865-00-P0	COVER, FRONT	1	MBL2

FIG. 32 WINDSHIELD

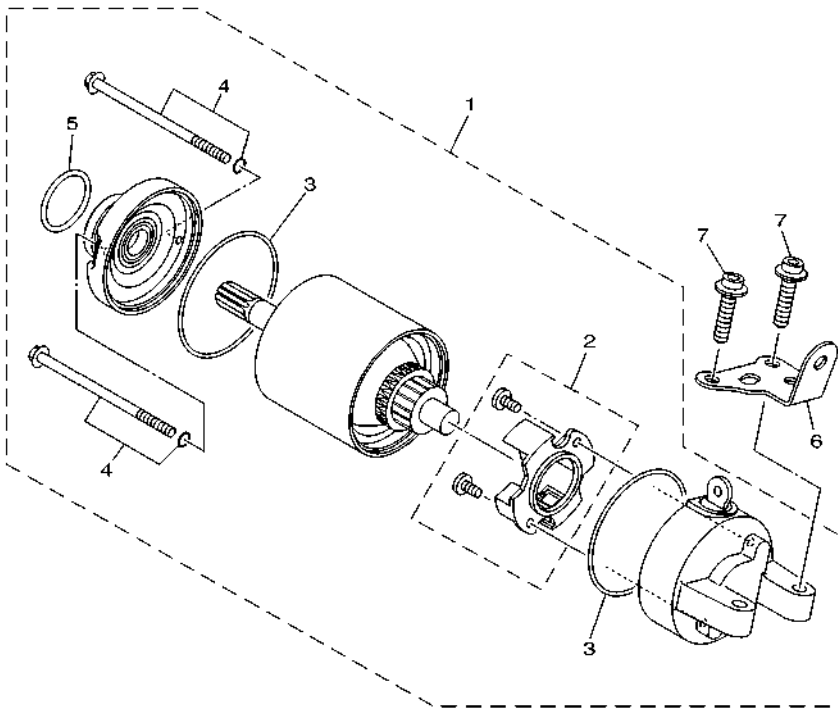


REF. NO.	PART NO.	DESCRIPTION	BU82				REMARKS
53	90464-07018	CLAMP	2				
54	90183-05807	NUT, SPRING	2				
55	B74-H2129-00	COVER, BATTERY	1				
56	97702-50012	SCREW, TAPPING	2				
57	90183-05807	NUT, SPRING	2				
58	90269-06816	RIVET	1				
59	B74-F837U-00	SCREEN	1				
60	90150-05024	SCREW, ROUND HEAD	4				
61	B74-F842A-00	COVER 5	1				
62	B74-F843C-00	COVER 6	1				
63	90269-08007	RIVET	2				
64	B92-F1737-00	EMBLEM	1				



**FIG. 34 STARTING MOTOR**

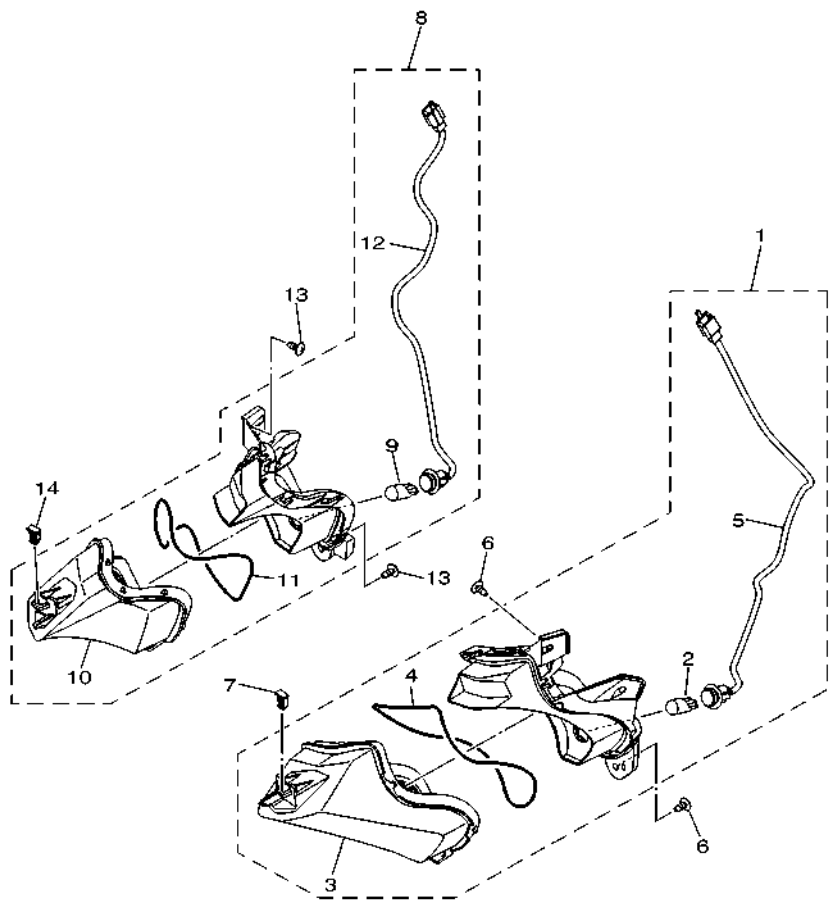
REF. NO.	PART NO.	DESCRIPTION	BU82				REMARKS
1	B74-H1890-00	MOTOR ASSY	1				
2	B74-H1801-00	.BRUSH SET	1				
3	1WD-H1861-00	.GASKET	2				
4	1WD-H1828-00	.BOLT 2	2				
5	4FP-H182L-00	.O-RING 1	1				
6	B74-H1948-00	BRACKET	1				
7	90110-06172	BOLT, HEXAGON SOCKET HEAD	2				



B741300-S340



**FIG. 35 FLASHER LIGHT**

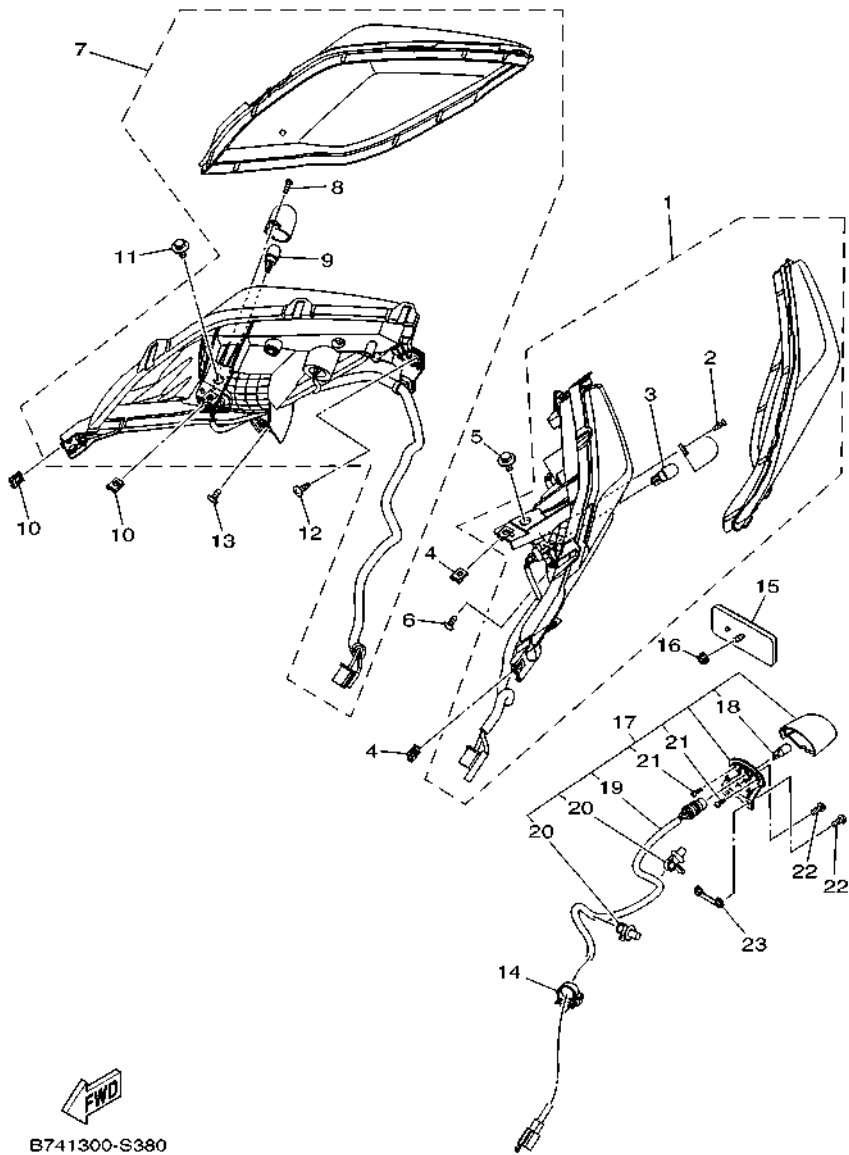


  
 B741300-S350

REF. NO.	PART NO.	DESCRIPTION	BU82				REMARKS
1	B74-H3310-00	FRONT FLASHER LIGHT ASSY 1	1				
2	2CB-H3311-00	.BULB, FLASHER (12V-10W)	1				
3	B74-H3312-00	.LENS, FLASHER	1				
4	B74-H4723-00	.GASKET, TAIL LENS	1				
5	B74-H4140-00	.SOCKET CORD ASSY	1				
6	97702-50012	SCREW, TAPPING	2				
7	90464-04004	CLAMP	1				
8	B74-H3320-00	FRONT FLASHER LIGHT ASSY 2	1				
9	2CB-H3311-00	.BULB, FLASHER (12V-10W)	1				
10	B74-H3322-00	.LENS, FLASHER 2	1				
11	B74-H4723-00	.GASKET, TAIL LENS	1				
12	B74-H4150-00	.SOCKET CORD ASSY 2	1				
13	97702-50012	SCREW, TAPPING	2				
14	90464-04004	CLAMP	1				





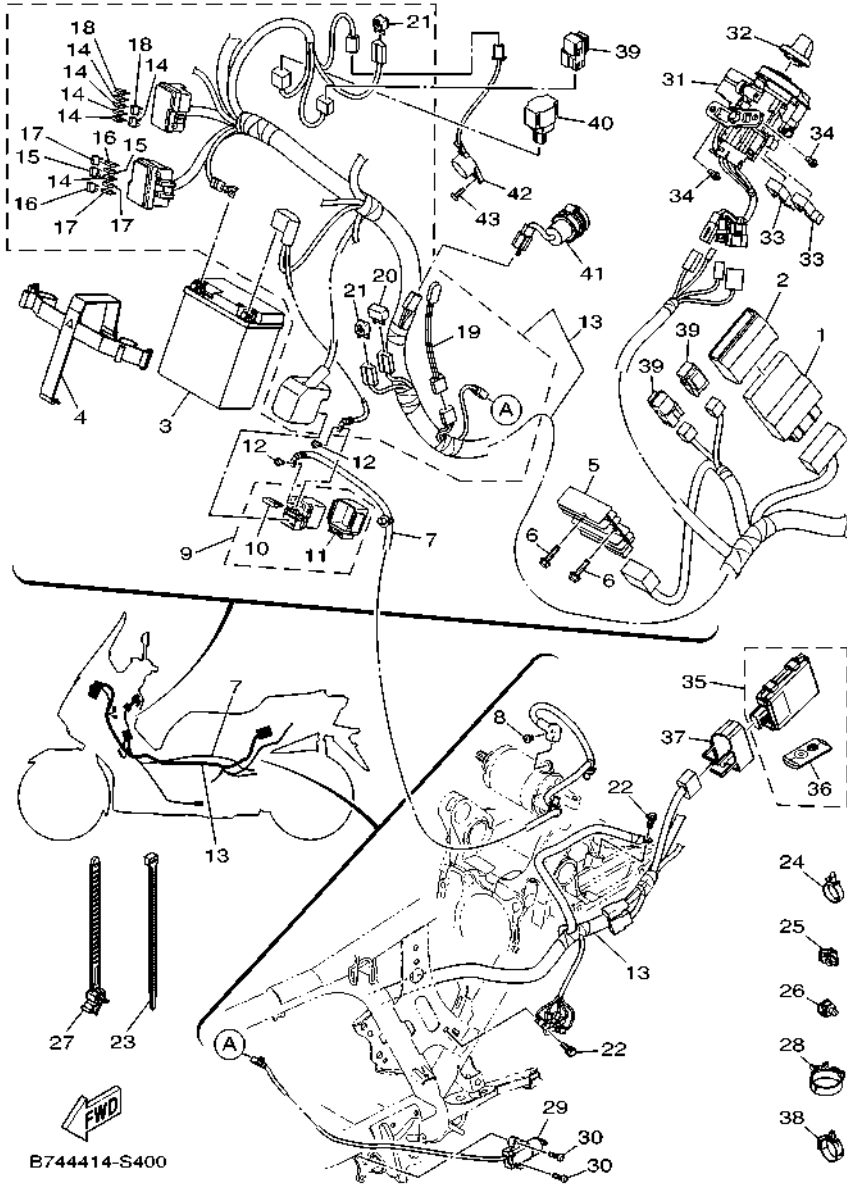


B741300-S380

FIG. 38 TAILLIGHT

REF. NO.	PART NO.	DESCRIPTION	BU82				REMARKS
1	B74-H4710-00	TAILLIGHT UNIT ASSY	1				
2	97702-40612	.SCREW, TAPPING	1				
3	1YT-83311-00	.BULB(12V-10W)	1				
4	90183-05807	NUT, SPRING	2				
5	90109-06887	BOLT	1				
6	97702-50012	SCREW, TAPPING	1				
7	B74-H4730-00	TAILLIGHT UNIT ASSY	1				
8	97702-40612	.SCREW, TAPPING	1				
9	1YT-83311-00	.BULB(12V-10W)	1				
10	90183-05807	NUT, SPRING	2				
11	90109-06887	BOLT	1				
12	97702-50016	SCREW, TAPPING	1				
13	97702-50012	SCREW, TAPPING	1				
14	90464-16006	CLAMP	1				
15	3C1-H5130-00	REAR REFLECTOR ASSY	1				
16	95702-05500	NUT, FLANGE	1				
17	B74-H4740-00	LICENCE LIGHT ASSY	1				
18	1WD-H4744-00	.BULB (12V-5W)	1				
19	B74-H4547-00	.CORD, LICENCE LIGHT	1				
20	B74-H454J-00	.CLAMP, CORD	2				
21	1WD-H4726-00	.SCREW	2				
22	92017-05012	BOLT, BUTTON HEAD	2				
23	B74-H4748-00	NUT, SPECIAL	1				





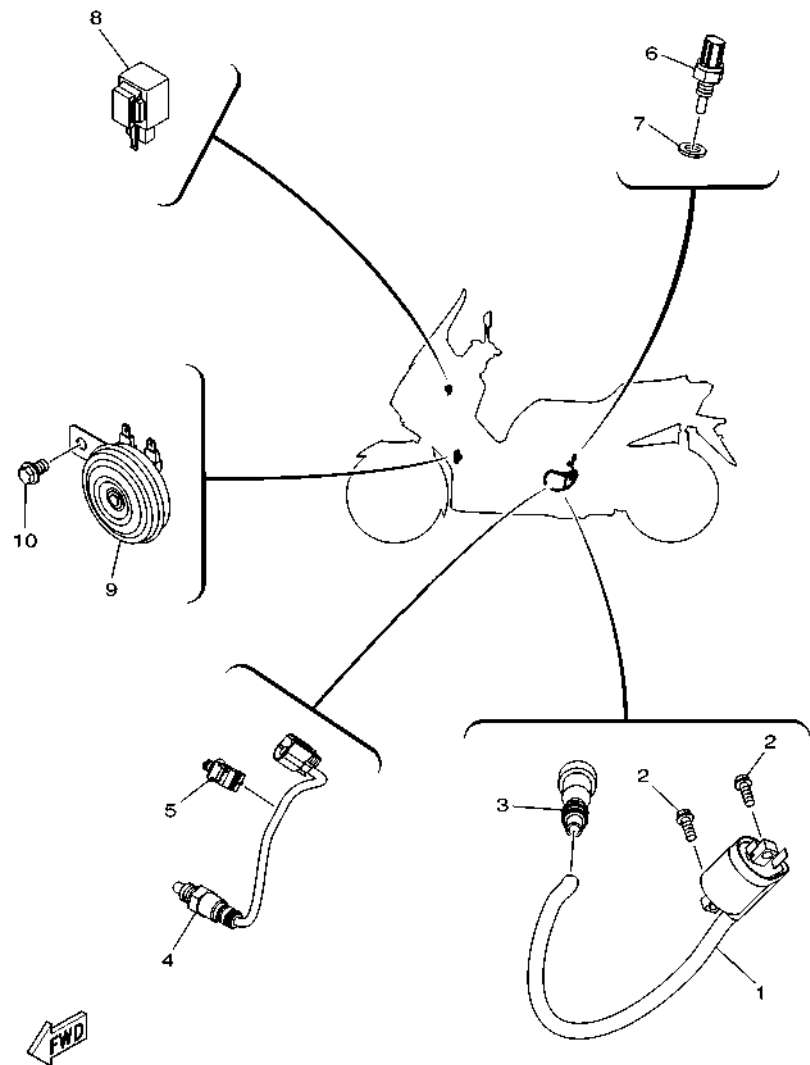
B744414-S400

FIG. 40 ELECTRICAL 1

REF. NO.	PART NO.	DESCRIPTION	BU82	REMARKS
1	BG6-H591A-20	ENGINE CONTROL UNIT ASSY	1	
2	B74-H2591-00	BAND	1	
3	2YD-H2100-00	BATTERY ASSY (GS GTZ8V)	1	
4	B74-H2131-00	BAND, BATTERY	1	
5	2GS-H1960-01	RECTIFIER & REGULATOR ASSY	1	
6	95822-06025	BOLT, FLANGE	2	
7	B74-H1815-00	CORD, STARTER MOTOR	1	
8	98902-05008	SCREW, BIND	1	
9	B74-H1940-00	STARTER RELAY ASSY	1	
10	B74-H2151-A0	.FUSE (20A)	1	
11	1WD-H2155-00	.BAND	1	
12	91312-05008	BOLT, HEXAGON SOCKET HEAD	2	
13	B74-H2590-11	WIRE HARNESS ASSY	1	
14	B65-H2151-00	.FUSE (7.5A)	6	
15	B65-H2151-10	.FUSE (15A)	2	
16	B65-H2151-60	.FUSE (30A)	2	
17	B65-H2151-80	.FUSE (2A)	3	
18	1LB-H2151-00	.FUSE (10A)	2	
19	1SD-H5700-00	.THERMISTOR ASSY	1	
20	4WA-81980-00	.DIODE ASSY	1	
21	3WP-81980-00	.DIODE ASSY	2	
22	95022-06012	BOLT, FLANGE	2	
23	90464-36800	CLAMP	1	
24	90464-24230	CLAMP	1	
25	90464-10008	CLAMP	1	
26	90464-12018	CLAMP	1	
27	90464-10112	CLAMP	1	(160X8.00)



**FIG. 41 ELECTRICAL 2**



B741300-S410

REF. NO.	PART NO.	DESCRIPTION	BU82				REMARKS
1	B74-H2310-00	IGNITION COIL ASSY	1				
2	95022-06016	BOLT, FLANGE	2				
3	B74-H2370-00	PLUG CAP ASSY	1				
4	B74-H592A-10	SENSOR, OXYGEN	1				
5	90464-12018	CLAMP	1				
6	54P-H3591-00	THERMO UNIT	1				
7	90430-10804	GASKET	1				
8	4GY-83350-00	FLASHER RELAY ASSY	1				
9	1WD-H3371-00	HORN	1				
10	95022-08012	BOLT, FLANGE	1				





NUMERICAL INDEX

PART NO.	REF. NO.	PART NO.	REF. NO.	PART NO.	REF. NO.	PART NO.	REF. NO.	PART NO.	REF. NO.	PART NO.	REF. NO.
B74-11391-00	1 - 18	B74-1216A-00	3 - 13	34X-25937-00	26 - 7	B74-E2439-00	5 - 2	BG6-E4711-00	9 - 2	B74-E7660-00	13 - 7
B74-11416-00	2 - 9	B74-1216A-20	3 - 13	3WP-81980-00	40 - 21	B74-E2446-00	6 - 39	54D-E4714-00	9 - 3	B74-E7664-00	13 - 11
B74-11416-10	2 - 9	B74-1216A-40	3 - 13	4WA-81980-00	40 - 20	B74-E2450-00	5 - 12	1WD-E4715-00	9 - 4	B74-E7668-00	13 - 20
B74-11416-20	2 - 9	B74-1216A-60	3 - 13	1YT-83311-00	38 - 3	B74-E2461-00	6 - 13	B74-E4718-00	9 - 6	BG6-E7670-00	13 - 8
B74-11416-30	2 - 9	B74-1216A-80	3 - 13		38 - 9	B65-E2462-00	6 - 32	B74-E475P-00	9 - 10	B74-E7674-00	13 - 5
B74-11416-40	2 - 9	B74-1216A-A0	3 - 13	4GY-83350-00	41 - 8	B74-E2467-00	6 - 36	B74-E476P-00	9 - 11	B74-E7674-10	13 - 12
B74-11416-50	2 - 9	B74-1216A-F0	3 - 13	BG6-E1102-00	1 - 1	B74-E2481-00	6 - 21	B74-E477P-00	9 - 12	B74-E7678-01	13 - 16
B74-11416-A0	2 - 9	B74-1216A-H0	3 - 13	B74-E111F-00	4 - 8	B74-E2482-00	6 - 26	B74-E4799-00	9 - 9	B74-E7678-10	13 - 18
B74-11417-00	2 - 10	B74-1216A-K0	3 - 13	40D-E1126-00	10 - 9	B74-E2483-00	6 - 27	2PV-E5113-00	10 - 19	B74-E7683-00	13 - 13
B74-11417-10	2 - 10	B74-1216A-M0	3 - 13	B74-E112F-00	4 - 6	B74-E2484-00	6 - 33	B74-E5150-00	10 - 1	B74-E7684-00	13 - 14
B74-11417-20	2 - 10	B74-1216A-R0	3 - 13	B74-E1133-10	1 - 2	B74-E2576-00	6 - 4	5D9-E5155-00	10 - 2	B74-F1110-01	15 - 1
B74-11417-30	2 - 10	B74-1216A-U0	3 - 13	B74-E1166-00	8 - 39	B74-E2591-00	6 - 30	5LW-E5363-00	10 - 24	B74-F1121-00	22 - 25
B74-11417-40	2 - 10	B74-1216A-W0	3 - 13	B74-E1169-00	1 - 11	5ST-E2615-00	6 - 8	5BP-E5363-10	5 - 6	B74-F1400-02	15 - 7
B74-11417-50	2 - 10	B74-1216A-Y0	3 - 13	B74-E1181-00	1 - 20	B74-E2662-00	3 - 11	B74-E5372-00	10 - 3	B74-F149S-00	15 - 5
B74-11417-A0	2 - 10	31G-12210-01	4 - 16	B74-E1185-00	1 - 10	1WD-E2671-00	6 - 11	B74-E5373-00	10 - 10	B74-F1511-00	16 - 1
BG6-11650-00	2 - 2	31G-12214-00	4 - 18	B74-E1191-00	1 - 9	5ST-E2843-00	6 - 9	B74-E5378-00	10 - 4	B74-F1513-00-P6	16 - 4
2C0-11654-00	2 - 3	31G-12222-00	4 - 17	B74-E1193-00	1 - 13	B74-E3300-00	7 - 1	B74-E5407-00	11 - 9	B74-F1513-00-P7	16 - 4
B74-11656-00	2 - 5	B74-12410-00	6 - 1	4YS-E1198-00	10 - 21	4ST-E3411-00	7 - 4	B74-E5411-00	11 - 1	B74-F1514-00-P6	16 - 6
B74-11656-10	2 - 5	52S-12439-00	6 - 2	BG6-E1311-01	1 - 24	1S7-E3440-00	7 - 7	B74-E5417-00	5 - 3	B74-F1514-00-P7	16 - 6
B74-11656-20	2 - 5	5GJ-12675-00	6 - 12	B74-E1351-00	1 - 25	B74-E3447-00	7 - 8	B74-E5421-00	10 - 26	BU8-F1568-00	31 - 67
B74-11656-30	2 - 5	5RU-13490-00	7 - 5	BG6-E1400-00	2 - 1	BG6-E3585-00	8 - 1	B74-E5431-00	11 - 5	2DP-F1578-00	16 - 10
B74-12168-00	3 - 13	52S-13938-00	8 - 9	BG6-E1500-00	2 - 11	BG6-E3595-00	8 - 2	B74-E5451-00	11 - 2	B74-F1611-00	16 - 22
B74-12168-20	3 - 13	B74-15338-00	11 - 14	B74-E1603-00	2 - 15	BG6-E3750-01	8 - 13	B74-E5453-00	10 - 15	B74-F1621-00	22 - 15
B74-12168-40	3 - 13	5PW-15361-00	5 - 16	BG6-E1631-00	2 - 14	BG6-E3761-00	8 - 6	B74-E5461-00	10 - 27	B74-F1651-00	16 - 11
B74-12168-60	3 - 13	B74-17411-00	14 - 1	B74-E1633-00	2 - 16	BG6-E3770-00	8 - 5	B74-E5471-00	11 - 7	B17-F1668-00	22 - 42
B74-12168-80	3 - 13	4G0-21639-00	16 - 29	B74-E1998-00	1 - 7	B74-E3907-00	21 - 5	B74-E5474-00	11 - 10	B74-F1711-00-P0	30 - 23
B74-12168-A0	3 - 13		31 - 47	B74-E1999-00	1 - 14	3C1-E3915-00	21 - 8	2DP-E5481-00	11 - 6	B74-F171E-00-P6	17 - 23
B74-12168-F0	3 - 13	4HC-23125-20	20 - 5	B74-E2111-00	3 - 1	B74-E3971-00	21 - 13	B74-E5512-00	12 - 1	B74-F171E-00-P7	17 - 23
B74-12168-H0	3 - 13		20 - 23	B74-E2113-00	3 - 4	54P-E4137-00	8 - 10	5BP-E5521-00	12 - 2	B74-F171L-00-P6	30 - 5
B74-12168-K0	3 - 13	22W-23146-L0	20 - 6	B74-E2117-00	3 - 6	54P-E4147-00	8 - 7	B74-E5524-00	12 - 3	B74-F171L-00-P7	30 - 5
B74-12168-M0	3 - 13		20 - 24	5TL-E2118-00	3 - 5	5CA-E4147-00	8 - 8	B74-E5590-00	12 - 4	B74-F171M-00-P6	30 - 16
B74-12168-R0	3 - 13	2N4-23168-00	20 - 18	54P-E2119-00	3 - 3	54P-E416A-00	8 - 16	B74-E5744-00	13 - 17	B74-F171M-00-P7	30 - 16
B74-12168-U0	3 - 13		20 - 36	B74-E2121-00	3 - 2	54P-E4243-00	8 - 15	B74-E6111-00	14 - 12	B74-F1721-00-P0	30 - 27
B74-12168-W0	3 - 13	3FV-23462-00	20 - 40	2PH-E2126-00	3 - 7	B74-E4335-00	8 - 18	B74-E6151-00	14 - 2	B74-F172A-00	16 - 14
B74-12168-Y0	3 - 13	3C1-24512-00	21 - 7	B74-E2146-00	3 - 10	BG6-E4411-00	8 - 19	B74-E6611-00	13 - 21	B74-F172F-00	16 - 18
B74-12169-10	3 - 13	B74-2476U-00	22 - 8	B74-E2151-00	3 - 8	B74-E4412-00	8 - 20	B74-E6620-00	13 - 19	2DP-F172W-00	30 - 11
B74-12169-30	3 - 13	B74-2476V-00	22 - 9	B74-E2157-00	5 - 4	B74-E4417-00	8 - 33	B74-E7211-00	14 - 6	B74-F1731-00-P6	17 - 1
B74-12169-50	3 - 13	5MT-25398-00	23 - 7	B74-E2161-00	3 - 9	B74-E4435-00	8 - 30	B74-E7412-00	13 - 27	B74-F1731-00-P7	17 - 1
B74-12169-70	3 - 13		25 - 4	BG6-E2170-00	4 - 1	B74-E4437-00	8 - 22	B74-E7421-00	14 - 5	B92-F1737-00	32 - 64
B74-12169-90	3 - 13	5MT-25398-10	23 - 7	B74-E2176-00	4 - 4	52B-E443E-00	8 - 27	B74-E7465-00	13 - 9	B74-F173B-00	17 - 11
B74-12169-E0	3 - 13		25 - 4	B74-E2213-00	4 - 19	5TP-E443G-10	8 - 31	B74-E7465-10	13 - 10		17 - 22
B74-12169-G0	3 - 13	5MT-25398-20	23 - 7	1DB-E2228-00	4 - 15	B74-E4449-00	8 - 29	B74-E7611-00	13 - 6	B74-F1741-00-P6	17 - 12
B74-12169-J0	3 - 13		25 - 4	B74-E2231-00	4 - 11	B74-E4452-00	8 - 24	B74-E7620-00	13 - 1	B74-F1741-00-P7	17 - 12
B74-12169-L0	3 - 13	5RB-25854-00	28 - 3	B74-E2233-00	4 - 12	B74-E4462-00	8 - 34	B74-E7623-00	13 - 3	B74-F1816-00	17 - 29
B74-12169-N0	3 - 13		28 - 21	B74-E2241-00	4 - 14	BG6-E4469-00	8 - 21	B74-E7632-00	13 - 2	B74-F1817-00	17 - 30
B74-12169-T0	3 - 13	36Y-2589H-00	28 - 5	B74-E2405-00	6 - 10	B74-E447F-00	8 - 43	B74-E7641-00	13 - 23	B74-F1823-00	6 - 22
B74-12169-V0	3 - 13		28 - 23	B74-E240A-00	6 - 7	B74-E4611-00	9 - 1	B74-E7644-00	13 - 15	B74-F1871-00	17 - 25
B74-12169-X0	3 - 13	5KN-25926-01	26 - 17	B74-E2422-00	5 - 1	1WD-E4613-00	9 - 13	B74-E7653-00	13 - 4	1S7-F1875-01	17 - 26

NUMERICAL INDEX

PART NO.	REF. NO.	PART NO.	REF. NO.	PART NO.	REF. NO.	PART NO.	REF. NO.	PART NO.	REF. NO.	PART NO.	REF. NO.
B74-F2100-00	18 - 1	B74-F3469-00	17 - 10	B74-F5183-00	18 - 8	4US-F6199-00	31 - 18	B74-F8351-00-P7	32 - 34	B65-H2151-60	40 - 16
B74-F2141-00	15 - 8		17 - 21	B74-F5338-00-33	25 - 1		31 - 34	B74-F8357-00	31 - 20	B65-H2151-80	40 - 17
B74-F2210-00	18 - 11	B74-F4110-01	21 - 1	1WD-F5802-00	24 - 4	B74-F6213-00	27 - 17	B74-F835J-00-P0	32 - 39	B74-H2151-A0	40 - 10
5MX-F2216-00	10 - 8	B74-F4135-00	21 - 20	1WD-F5802-50	26 - 4	2DP-F6240-00	27 - 3	B74-F835K-00-P0	32 - 48	1WD-H2155-00	40 - 11
	18 - 5	B74-F414A-00	21 - 17	1WD-F5803-00	24 - 5	2DP-F6241-00	27 - 2	B74-F835P-00	32 - 23	B74-H2310-00	41 - 1
B74-F2591-00	6 - 24	B74-F414B-00	32 - 42	1WD-F5803-50	26 - 5	1PA-F6246-10	27 - 4	B74-F835X-00	31 - 38	B74-H2370-00	41 - 3
B74-F2865-00-P0	32 - 52		32 - 51	B74-F5805-00	24 - 12	B74-F6280-00	27 - 11	B74-F8365-00	31 - 39	B74-H2501-10	40 - 31
B74-F286F-00	32 - 29	5D9-F414G-00	21 - 3	B74-F5806-00	26 - 15	B74-F6290-00	27 - 12	B74-F836B-00	27 - 23	B74-H251P-00	15 - 3
BG6-F3102-00	20 - 1	1DW-F4180-02	21 - 19	B74-F5807-00	28 - 2	B74-F6301-00	27 - 6	B74-F836K-00	31 - 1	2DP-H2530-00	28 - 29
BG6-F3103-00	20 - 19	B74-F419A-00	21 - 14		28 - 20	B74-F637G-00	27 - 9	B74-F836L-00	31 - 7	BB8-H254B-00	40 - 41
BG6-F3107-00	20 - 3	B74-F4313-00	21 - 18	B74-F580U-00	24 - 3	B74-F7111-00	29 - 6	B74-F836M-00	31 - 24	B74-H2566-00	40 - 29
	20 - 21	BG6-F4314-00	21 - 21	B74-F580W-00	26 - 3	45P-F7114-00	29 - 8	B74-F837-00-P6	32 - 43	1PA-H2576-00	40 - 40
5BP-F3111-10	20 - 17	B74-F4425-00	21 - 11	B74-F581J-00	28 - 42	4YY-F7114-00	29 - 16	B74-F8377-00-P7	32 - 43	B74-H2590-11	40 - 13
	20 - 35	3C1-F4486-00	21 - 10	B74-F582U-00	24 - 1	B74-F7261-00	29 - 9	B74-F837L-00	31 - 63	B74-H2591-00	40 - 2
2JK-F3114-00	20 - 16	B74-F4494-00	31 - 56	B74-F582W-00	26 - 1	B74-F7311-00	29 - 11	B74-F837M-00	31 - 65	B74-H276E-10	40 - 32
	20 - 34	3C1-F4519-00	21 - 6	5TL-F5838-00	26 - 18	B74-F741L-00	29 - 19	B74-F837N-00	32 - 1	B74-H3310-00	35 - 1
B74-F3118-00	20 - 15	B74-F4610-00	21 - 16	1WD-F5852-00	28 - 4	B74-F742L-00	29 - 28	B74-F837U-00	32 - 59	2CB-H3311-00	35 - 2
	20 - 33	B74-F4639-00	22 - 22		28 - 22	B74-F7430-00	29 - 17	B74-F8385-00	29 - 1		35 - 9
B65-F3123-00	20 - 41	B74-F465B-00	22 - 33	3C1-F5855-00	28 - 7	2DP-F7431-01	29 - 18	B74-F838L-00	31 - 15	B74-H3312-00	35 - 3
B74-F3126-00	20 - 2	B74-F465E-00	22 - 32		28 - 25	B74-F7437-00	29 - 24	B74-F838N-00	29 - 4	B74-H3320-00	35 - 8
B74-F312H-00	19 - 9	B74-F470F-00	22 - 3	B74-F5867-00	28 - 6		29 - 33	B74-F838V-00	31 - 33	B74-H3322-00	35 - 10
B74-F3136-00	20 - 20	B74-F471D-00	22 - 36		28 - 24	B74-F7440-00	29 - 26	B74-F838W-00	31 - 52	1WD-H3371-00	41 - 9
B74-F3141-00	20 - 13	B74-F4723-00	22 - 10	B74-F5870-00	28 - 19	2DP-F7441-01	29 - 27	B74-F839L-00	31 - 9	B3F-H3383-00	40 - 42
	20 - 31	B74-F4727-00	22 - 20	B74-F5870-10	28 - 1	B74-F7481-00	30 - 1	B74-F839V-00	31 - 26	B74-H3500-30	36 - 1
5BP-F3144-00	20 - 9	B74-F472T-00	22 - 30	B74-F5872-00	28 - 14	B74-F7483-00	30 - 31	B74-F839W-00	31 - 46	B74-H3511-00	36 - 3
	20 - 27	B74-F4730-00	22 - 1	B74-F5873-00	28 - 32	B74-F7484-00	30 - 32	B74-F842A-00	32 - 61	B74-H353L-00	36 - 2
5BP-F3145-00	20 - 7	B74-F473R-00	22 - 6	B74-F5874-00	28 - 35	B74-F7488-00	30 - 12	B74-F842M-00	31 - 61	B74-H3572-00	36 - 4
	20 - 25	B74-F4741-00	22 - 2	B74-F5875-00	28 - 38	B74-F7493-00	30 - 33	B74-F843C-00	32 - 62	54P-H3591-00	41 - 6
2JK-F3149-01	20 - 14	B74-F474A-00-P6	17 - 4	B74-F5876-00	28 - 47	B74-F7494-00	30 - 34	B74-H1410-00	33 - 2	B74-H3912-00	28 - 26
	20 - 32	B74-F474A-00-P7	17 - 4	B74-F587A-00	28 - 50	B74-F74A8-00-P0	31 - 44	B74-H1450-00	33 - 1	B74-H3922-00	28 - 8
22W-F3156-L0	20 - 8	B74-F474E-00	22 - 24	B74-F5886-00	28 - 17	B74-F8100-00	22 - 40	B74-H1639-00	10 - 30	B74-H3963-00	39 - 1
	20 - 26	B74-F474W-00-P6	17 - 15	B74-F5887-00	28 - 40	B74-F8175-00	22 - 41	B74-H1801-00	34 - 2	B74-H3973-10	39 - 3
2BU-F3158-00	20 - 11	B74-F474W-00-P7	17 - 15	1WD-F5914-50	26 - 16	B74-F818A-00	31 - 12	B74-H1815-00	40 - 7	2DP-H3980-00	28 - 11
	20 - 29	B74-F475M-00	22 - 7	5YP-F5917-00	24 - 8		31 - 30	1WD-H1828-00	34 - 4	B74-H4140-00	35 - 5
2CM-F3166-00	20 - 10	1S7-F4768-00	22 - 39		26 - 6		31 - 49	4FP-H182L-00	34 - 5	B74-H4150-00	35 - 12
	20 - 28	B74-F4769-00	22 - 17	1WD-F5919-00	24 - 10	B74-F8306-00	32 - 22	1WD-H1861-00	34 - 3	B74-H4300-00	37 - 1
B74-F3170-00	20 - 4	1DY-F4780-00	31 - 22	B74-F5919-50	26 - 9	B74-F8311-00	31 - 5	B74-H1890-00	34 - 1	B74-H4547-00	38 - 19
	20 - 22		31 - 54	B74-F5921-50	26 - 12	B74-F8312-00-P0	31 - 59	B74-H1940-00	40 - 9	B74-H454J-00	38 - 20
31B-F3181-00	20 - 12	B65-F4780-00	22 - 28	5YP-F5924-00	24 - 11	B74-F8321-00	32 - 6	B74-H1948-00	34 - 6	B74-H4550-00	16 - 26
	20 - 30	B74-F4785-00	22 - 19	1WD-F5924-50	26 - 10	B74-F8322-00	32 - 24	B74-H1950-00	40 - 39	B74-H4710-00	38 - 1
B74-F3317-00	24 - 14	B74-F4786-00	22 - 4	5YP-F5925-01	24 - 9	B74-F8332-00	32 - 25	2GS-H1960-01	40 - 5	B74-H4723-00	35 - 4
B74-F3340-00	20 - 37	B74-F478E-00	22 - 27		26 - 11	B74-F8336-00	31 - 28	2YD-H2100-00	40 - 3		35 - 11
2JK-F3346-00	20 - 38	B74-F478G-00	22 - 23	5YP-F5937-00	24 - 7	B74-F8346-00-P0	31 - 4	B74-H2129-00	32 - 55	1WD-H4726-00	38 - 21
5BP-F3416-10	19 - 2	B74-F479D-00	22 - 38	1WD-F5939-51	26 - 13	B74-F8349-00	31 - 17	B74-H212B-00	32 - 12	B74-H4730-00	38 - 7
5BP-F3418-00	19 - 5	B74-F5168-00-33	23 - 1	1WD-F5939-61	26 - 14	B74-F834F-00	31 - 14	B74-H2131-00	40 - 4	B74-H4740-00	38 - 17
B74-F3435-00	19 - 6	2DP-F517G-00	23 - 8	B74-F6110-00	27 - 1		31 - 32	1LB-H2151-00	40 - 18	1WD-H4744-00	38 - 18
B74-F3441-00	19 - 12		25 - 5	B74-F6144-00	27 - 13		31 - 51	B65-H2151-00	40 - 14	B74-H4748-00	38 - 23
B74-F3442-00	19 - 11	B74-F5181-00	23 - 11	B74-F6145-00-P0	27 - 21		32 - 34	B65-H2151-10	40 - 15	B74-H4770-00	22 - 11

NUMERICAL INDEX

PART NO.	REF. NO.	PART NO.	REF. NO.	PART NO.	REF. NO.	PART NO.	REF. NO.	PART NO.	REF. NO.	PART NO.	REF. NO.
2FC-H5111-00	16 - 24	90110-06178	33 - 3	90183-05807	30 - 26	90269-07007	6 - 31	90464-12018	41 - 5	90520-10835	11 - 13
B74-H5112-00	42 - 5	90110-06182	4 - 13		30 - 30	90269-08007	32 - 63	90464-13185	21 - 2	90520-10836	8 - 42
3C1-H5130-00	38 - 15	90110-06187	4 - 7		31 - 6	90269-09005	30 - 7	90464-13801	31 - 35	90520-10837	11 - 11
B65-H5546-00	40 - 37	90110-06380	32 - 26		31 - 8		30 - 18	90464-14803	42 - 4	90520-20821	11 - 12
1SD-H5700-00	40 - 19	90110-06405	4 - 5		31 - 25	90280-05013	2 - 8	90464-16006	38 - 14	91312-05008	40 - 12
B74-H5752-00	21 - 9	90110-06868	1 - 23		31 - 45	90338-06809	22 - 13	90464-24230	40 - 24	91312-05010	21 - 12
B74-H5801-00	8 - 17	90111-05810	40 - 30		32 - 5	90338-14802	8 - 36	90464-30001	40 - 38		22 - 37
BG6-H591A-20	40 - 1	90111-06807	9 - 7		32 - 16	90340-12808	10 - 20	90464-36006	40 - 28	91312-05014	3 - 12
B74-H592A-10	41 - 4	90111-06839	30 - 25		32 - 30	90340-18002	1 - 3	90464-36800	22 - 34	91312-06016	42 - 6
B74-H5930-09	42 - 1		30 - 29		32 - 41	90340-32805	5 - 10		40 - 23	91312-06025	4 - 20
B74-H5970-00	42 - 2		32 - 20		32 - 50	90387-06048	32 - 18	90467-10038	6 - 5	91312-08030	19 - 8
B74-H5980-00	42 - 7	90111-08087	26 - 2		32 - 54	90387-06158	32 - 37	90467-12052	10 - 11	91317-06030	27 - 5
B74-H6260-04	40 - 35	90119-06051	30 - 9		32 - 57		32 - 46	90467-12809	8 - 28	91402-25015	29 - 23
B74-H6261-02	40 - 36		30 - 20		37 - 5	90387-064W3	6 - 15		8 - 32		29 - 32
4C9-W0048-00	24 - 6		31 - 41		38 - 4	90387-06899	37 - 4	90467-13808	8 - 40	91702-08038	29 - 22
5YP-W0048-50	26 - 8		32 - 2		38 - 10	90387-068N8	32 - 9	90467-14807	8 - 41		29 - 31
B74-WE445-00	8 - 23	90119-068A2	21 - 4	90183-06818	27 - 15	90387-08839	17 - 9	90467-20805	6 - 28	91810-14809	10 - 16
90101-10830	29 - 13	90149-05029	23 - 9		31 - 16		17 - 20	90467-21801	6 - 29		10 - 28
90105-10883	2 - 6		25 - 6		31 - 53	90387-09805	32 - 14	90467-22002	6 - 19		11 - 3
90105-12805	15 - 10	90149-06104	27 - 22		32 - 17	90387-09808	32 - 19	90467-24800	6 - 20	92012-06010	27 - 7
90105-12806	15 - 9	90149-10804	24 - 13	90185-14801	23 - 13	90387-10849	29 - 15	90467-250A1	6 - 34	92012-06020	22 - 35
90105-12807	13 - 25	90150-05024	32 - 60	90185-16800	18 - 10	90387-15834	23 - 10	90467-26131	6 - 35	92017-05012	38 - 22
90109-06009	32 - 27	90160-05808	27 - 19	90201-06033	6 - 16	90387-15835	23 - 4	90468-18121	22 - 21	92017-05016	27 - 8
90109-06220	22 - 14		30 - 22	90201-06088	16 - 27	90387-17807	18 - 9	90480-01558	32 - 33	93102-25826	14 - 14
	31 - 58		30 - 24	90201-10118	28 - 16	90401-10812	28 - 15	90480-01559	17 - 3	93102-35805	10 - 14
90109-06318	40 - 34		30 - 28		28 - 34		28 - 33		17 - 14	93102-35806	14 - 11
90109-06577	28 - 10		31 - 2		28 - 37		28 - 36		30 - 2	93103-10801	5 - 14
	28 - 28		32 - 3		28 - 44		28 - 43		30 - 13	93106-22808	23 - 2
90109-06887	6 - 37	90167-05076	27 - 18	90201-10848	2 - 7	90430-06014	1 - 5	90480-10289	32 - 7	93106-28801	18 - 3
	16 - 17	90170-14802	13 - 26	90201-10849	1 - 17		5 - 9		37 - 3	93106-28813	18 - 4
	16 - 21	90179-05003	32 - 28	90201-15813	23 - 12	90430-08119	10 - 23	90480-10332	9 - 8	93210-10096	7 - 6
	16 - 23	90179-06055	16 - 3	90201-18262	10 - 5	90430-10148	5 - 5	90480-13567	17 - 28	93210-12801	4 - 2
	17 - 7	90179-06841	32 - 15	90201-19014	13 - 24	90430-10804	41 - 7	90480-14023	32 - 36	93210-14816	10 - 25
	17 - 18	90179-07001	2 - 4	90201-23015	13 - 22	90450-52008	8 - 38		32 - 45	93210-18397	10 - 7
	17 - 27	90179-10818	1 - 16	90201-23801	13 - 29	90450-56009	8 - 12	90480-14229	32 - 8	93210-198J0	5 - 7
	29 - 3	90179-22025	19 - 7	90202-26142	19 - 4	90464-04004	30 - 3	90480-14818	6 - 18	93210-22800	6 - 40
	30 - 8	90179-25810	19 - 3	90269-06812	31 - 40		30 - 14	90480-15483	6 - 14	93210-32816	5 - 11
	30 - 19	90183-05807	16 - 5	90269-06816	6 - 38		35 - 7	90501-12743	29 - 20	93210-40659	8 - 3
	31 - 37		16 - 7		16 - 13		35 - 14		29 - 29	93210-48530	7 - 10
	32 - 13		16 - 12		22 - 16	90464-06008	28 - 45	90506-32813	29 - 12	93300-205Y0	14 - 13
	38 - 5		16 - 16		22 - 31	90464-07018	32 - 53	90506-40805	29 - 7	93306-000Y3	5 - 13
	38 - 11		16 - 20		27 - 20	90464-07805	28 - 46	90508-13800	31 - 13	93306-002XH	4 - 3
90109-068A4	16 - 8		17 - 2		31 - 42	90464-09806	40 - 33	90508-13801	31 - 31	93306-078Y1	14 - 9
90109-08232	24 - 2		17 - 13		31 - 60	90464-10008	21 - 22	90508-14803	31 - 50	93306-204XV	2 - 13
90110-06161	12 - 5		27 - 16		31 - 64		40 - 25	90520-04015	15 - 2	93306-272YC	14 - 4
	33 - 4		29 - 2		31 - 66	90464-10112	40 - 27	90520-06808	31 - 10	93306-303YT	2 - 12
90110-06172	8 - 4		30 - 6		32 - 4	90464-10802	6 - 6		31 - 27		14 - 3
	34 - 7		30 - 17		32 - 58	90464-12018	40 - 26	90520-10834	22 - 12	93306-303YV	18 - 2

NUMERICAL INDEX

PART NO.	REF. NO.	PART NO.	REF. NO.	PART NO.	REF. NO.	PART NO.	REF. NO.	PART NO.	REF. NO.	PART NO.	REF. NO.
93306-304YW	14 - 8	95027-06025	28 - 13	97702-40612	38 - 8	99009-47500	18 - 6				
93399-99932	20 - 39		28 - 31	97702-50012	16 - 2	99009-52500	14 - 10				
93399-999Y3	19 - 1	95027-06035	16 - 9		16 - 15	99530-08012	10 - 12				
933A6-202Y1	23 - 3	95027-08035	9 - 5		16 - 19	99530-14016	1 - 21				
93430-12809	29 - 10	95602-06100	16 - 28		17 - 6		1 - 22				
93450-17129	2 - 17		28 - 9		17 - 17						
93501-04830	29 - 21		28 - 27		30 - 4						
	29 - 30	95602-10200	18 - 13		30 - 10						
93900-00828	23 - 6		29 - 14		30 - 15						
	25 - 3	95602-12200	15 - 11		30 - 21						
94112-15800	23 - 5	95612-08620	1 - 6		31 - 3						
94114-14803	25 - 2	95702-05500	38 - 16		31 - 48						
94568-F9058	7 - 3	95702-06500	22 - 18		31 - 62						
94568-H8110	4 - 10	95702-08500	9 - 14		32 - 32						
94700-00436	1 - 19	95707-05500	16 - 25		32 - 38						
95022-06012	1 - 4	95802-06012	28 - 49		32 - 47						
	1 - 8		28 - 51		32 - 56						
	4 - 9	95802-06016	42 - 3		35 - 6						
	6 - 23		42 - 8		35 - 13						
	6 - 25	95802-06020	32 - 10		38 - 6						
	15 - 4		37 - 2		38 - 13						
	15 - 6	95802-06025	32 - 35	97702-50016	17 - 5						
	19 - 10		32 - 44		17 - 16						
	21 - 15	95807-06010	28 - 48		17 - 24						
	22 - 29	95807-06012	28 - 39		27 - 14						
	27 - 10		28 - 41		29 - 5						
	28 - 18	95812-06025	8 - 11		31 - 43						
	31 - 21	95812-06030	8 - 37		32 - 31						
	31 - 23	95812-08016	10 - 22		32 - 40						
	31 - 55		29 - 25		32 - 49						
	32 - 21		29 - 34		36 - 6						
	40 - 22	95812-08020	17 - 8		38 - 12						
95022-06016	1 - 12		17 - 19		40 - 43						
	41 - 2	95812-08055	32 - 11	97702-50020	8 - 35						
95022-06020	6 - 3	95812-10030	26 - 19	97707-50012	31 - 11						
	7 - 9	95812-10060	18 - 7		31 - 19						
95022-06025	1 - 15	95817-08030	18 - 14		31 - 29						
	11 - 4	95817-10040	18 - 12		31 - 36						
95022-06040	10 - 17	95817-10045	9 - 15	97707-50025	8 - 25						
95022-06060	7 - 2	95822-06025	40 - 6	97707-50035	8 - 26						
	10 - 18	95827-06020	6 - 41	98502-06012	8 - 14						
95022-06070	10 - 13	95827-06025	6 - 17	98507-05025	39 - 4						
95022-08012	22 - 26	97527-05512	31 - 57	98507-05040	39 - 2						
	41 - 10	97602-04212	28 - 12	98902-05008	40 - 8						
95022-08040	10 - 29		28 - 30	99009-10400	5 - 15						
95022-08055	19 - 13	97702-30016	36 - 5	99009-18400	10 - 6						
95027-06016	11 - 8	97702-40012	22 - 5	99009-28400	14 - 7						
95027-06020	5 - 8	97702-40612	38 - 2	99009-40700	13 - 28						