

# PARTS CATALOGUE 2019

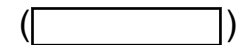


**MTN850-A** ( B2K2 ) MALAYSIA

MT09



1UB2K-440E1



MTN850-A  
PARTS CATALOGUE  
©2018 by Yamaha Motor Co., Ltd.  
1st edition, November 2018  
All rights reserved.  
Any reprinting or unauthorized use  
without the written permission of  
Yamaha Motor Co., Ltd.  
is expressly prohibited.  
Printed in Japan.

# FOREWORD

This Parts Catalogue is related to the parts for the model(s) on the cover page. When you are ordering replacement parts, please refer to this Parts Catalogue and quote both part numbers and part names correctly.

1. Modifications or additions which have been made after the issue of the Parts Catalogue will be announced in the Parts News.  
It is advisable that you make the necessary corrections to the Parts Catalogue according to the Parts News.

2. Abbreviations

The following abbreviations are used in this Parts Catalogue.

“UR” Use specified parts number.

“UN” Use as many as needed.

“AP” Alternate Parts

“LM” Locally Made (Parts need to be ordered locally)

“F#” Frame No. (Applicable machine No.)

“O/S” Over Size

3. The number of components for assembly

- Parts, which are to be supplied in an assembly, are listed with a dot (.) in front of the part name as shown below.
- The numeral appearing to the right of each component part indicates the quantity of parts for each assembly unit.

PART NO.	DESCRIPTION	Q'TY	REMARKS
2F5-83310-60	FRONT FLASHER LIGHT ASSY	2	
115-83311-60	.BULB (6V-18W)	1	

4. Applicable colours of graphics are represented in the “REMARKS” as shown below.

PART NO.	DESCRIPTION	Q'TY	REMARKS
2N4-24110-00-X5	FUEL TANK COMP.	2	MXR
3J1-24240-10	.GRAPHIC, FUEL TANK	1	FOR MXR

5. Note that the illustrations for reference in finding parts numbers are not to be used for assembling. When assembling, please use the applicable service manual.

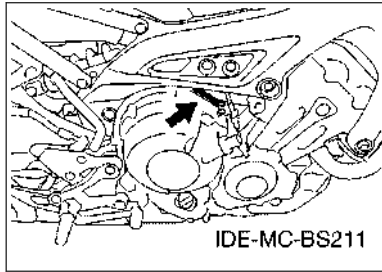
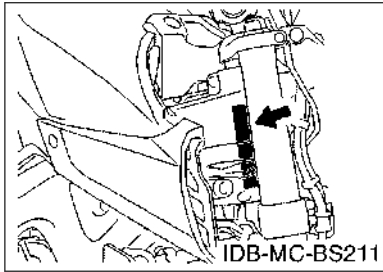
6. The asterisk (\*) before a reference number indicates modified items after the first edition.

# FOREWORD

7. Applicable Serial No.

Frame Serial No.

Engine Serial No.



8. Applicable Colour Code (The (\*) mark shows Model colour.)

Abbreviation	Colour Name	Colour Code
DPBM15	DEEP PURPLISH BLUE METALLIC 15	1329
DPBMC(*)	DEEP PURPLISH BLUE METALLIC C	0564
MBL2	MAT BLACK 2	0582
MLNM4(*)	MAT LIGHT GRAY METALLIC 4	1700
VYRS6	VIVID YELLOWISH RED SOLID 6	1699
YB	YAMAHA BLACK	0033

9. Applicable Starting Serial No.

Frame Serial No.

Serial No.	Name Of Q'ty Column	Model Code

Engine Serial No.

Serial No.	Name Of Q'ty Column	Model Code

# CONTENTS

## ENGINE

CYLINDER HEAD.....	1
CRANKSHAFT & PISTON.....	3
VALVE.....	4
CAMSHAFT & CHAIN.....	6
WATER PUMP.....	7
RADIATOR & HOSE.....	9
OIL PUMP.....	12
OIL CLEANER.....	13
INTAKE.....	14
INTAKE 2.....	15
AIR INDUCTION SYSTEM.....	17
EXHAUST.....	18
CRANKCASE.....	19
CRANKCASE COVER 1.....	21
STARTER.....	23
CLUTCH.....	24
TRANSMISSION.....	26
SHIFT CAM & FORK.....	28
SHIFT SHAFT.....	29

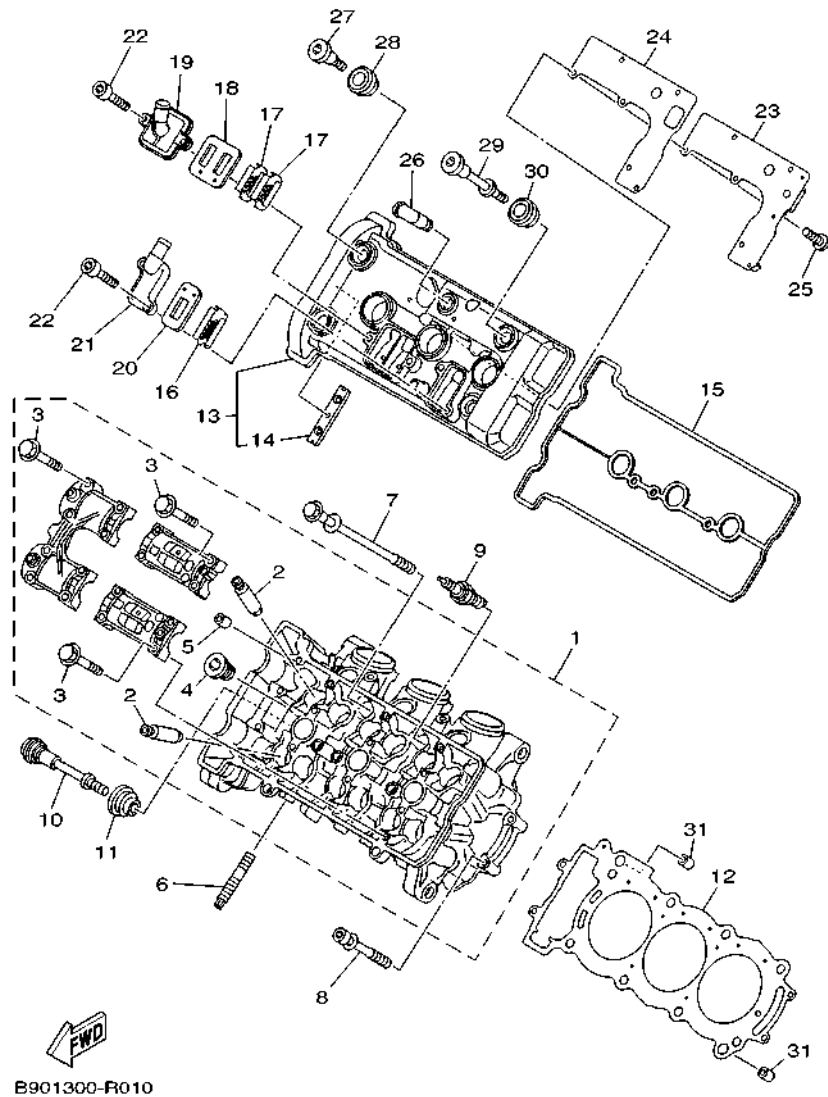
## CHASSIS

FRAME.....	31
FENDER.....	32
SIDE COVER.....	35
REAR ARM.....	38
REAR SUSPENSION.....	41
STEERING.....	42
FRONT FORK.....	43
FUEL TANK.....	45
SEAT.....	47
FRONT WHEEL.....	48
FRONT BRAKE CALIPER.....	49
REAR WHEEL.....	51
REAR BRAKE CALIPER.....	53
STEERING HANDLE & CABLE.....	54
FRONT MASTER CYLINDER.....	55
STAND & FOOTREST.....	56
REAR MASTER CYLINDER.....	59
GENERATOR.....	61

STARTING MOTOR.....	62
FLASHER LIGHT.....	63
METER.....	64
HEADLIGHT.....	65
TAILLIGHT.....	67
HANDLE SWITCH & LEVER.....	68
ELECTRICAL 1.....	69
ELECTRICAL 2.....	71
ELECTRICAL 3.....	72

## INDEX

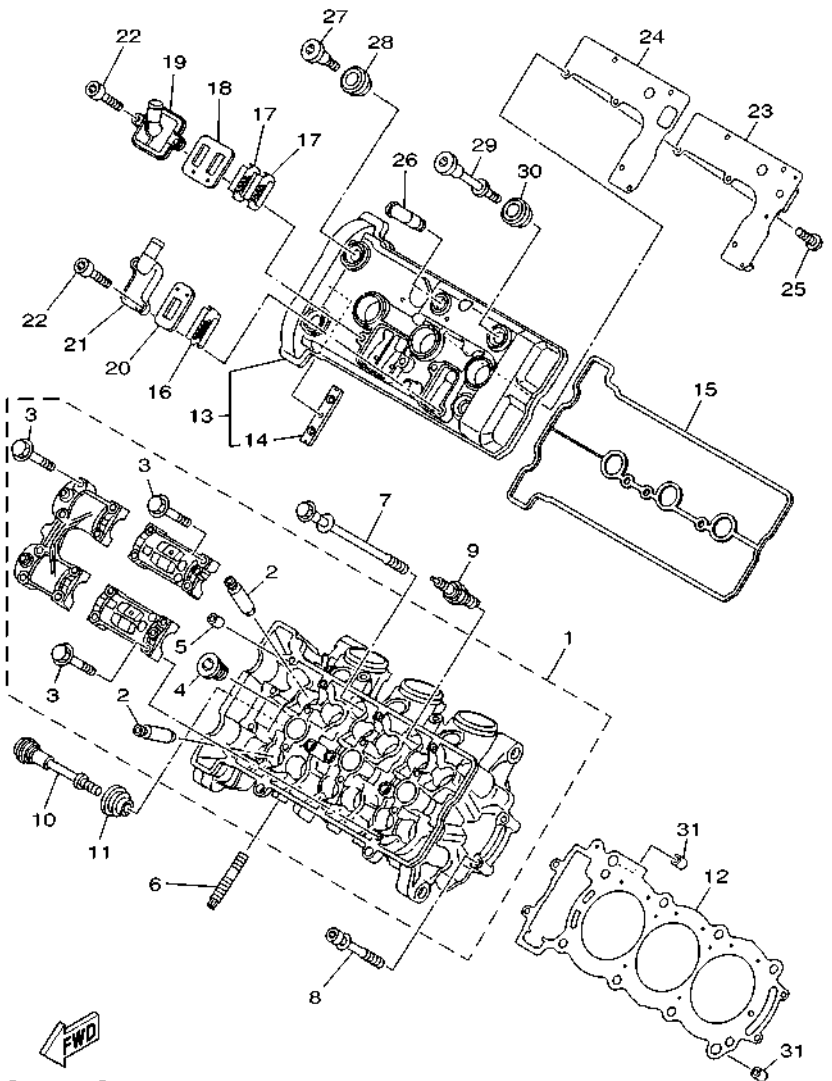
NUMERICAL INDEX.....	73
----------------------	----



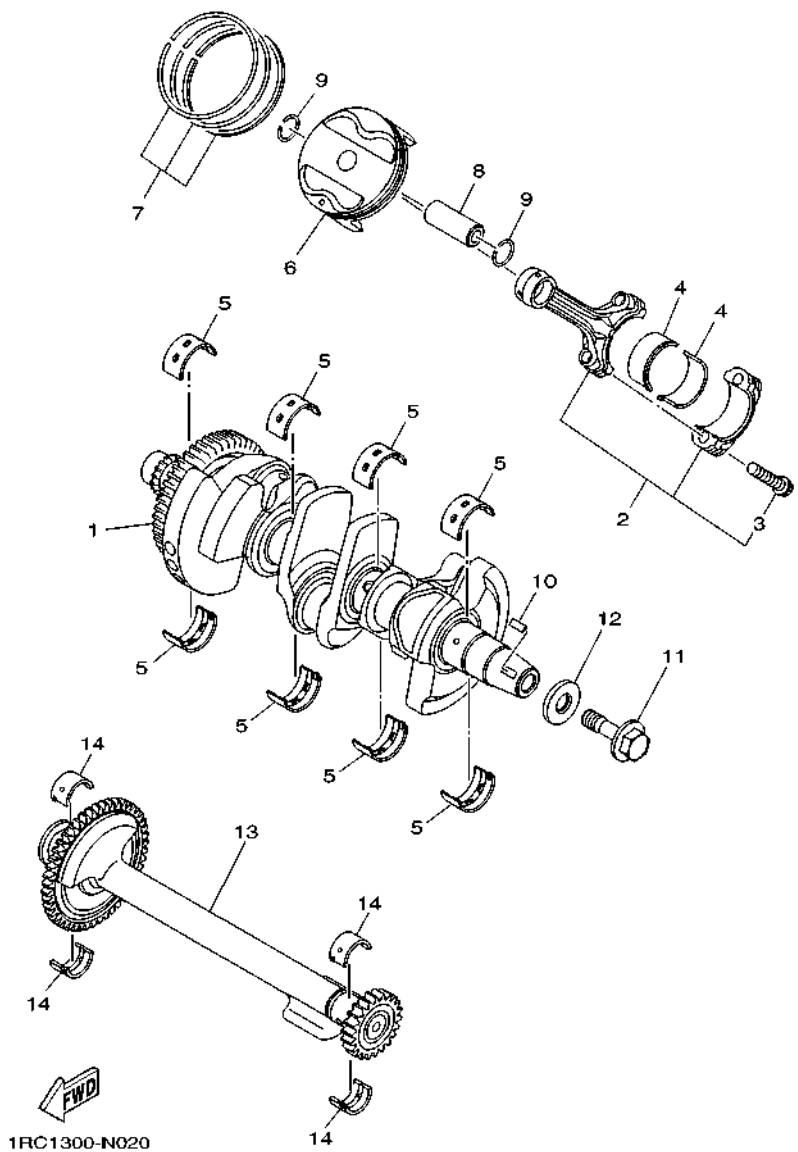
**FIG. 1 CYLINDER HEAD**

REF. NO.	PART NO.	DESCRIPTION	B2K2				REMARKS
1	B90-11101-09	CYLINDER HEAD ASSY	1				
2	2C0-11133-11	.GUIDE, VALVE 1	12				
3	90105-06027	.BOLT, FLANGE	16				
4	90340-18002	.PLUG, STRAIGHT SCREW	2				
5	91808-16023	.PIN, DOWEL	6				
6	90116-08087	BOLT, STUD	6				
7	90119-09017	BOLT, WITH WASHER	8				
8	90109-061F7	BOLT	4				
9	94701-00431	PLUG, SPARK (NGK R CPR9EA-9)	3				
10	90109-06293	BOLT	1				
11	5VY-1111G-00	RUBBER, MOUNT 1	1				
12	BS2-11181-00	GASKET, CYLINDER HEAD 1	1				
13	1RC-11191-00	COVER, CYLINDER HEAD 1	1				
14	5BE-12241-00	.GUIDE, STOPPER 2	1				
15	1RC-11193-01	GASKET, HEAD COVER 1	1				
16	5JW-1482K-01	PLATE	1				
17	5VY-1482K-00	PLATE	2				
18	5SL-14890-00	REED VALVE ASSY	1				
19	5SL-14899-00	CAP, CASE	1				
20	5PS-14890-00	REED VALVE ASSY	1				
21	5JW-14889-00	CAP, CASE	1				
22	90110-06175	BOLT, HEXAGON SOCKET HEAD	4				
23	B90-11165-00	PLATE, BREATHER	1				
24	1RC-11169-00	GASKET, BREATHER COVER	1				
25	90149-05037	SCREW	5				
26	BD5-11167-00	PIPE, BREATHER 2	1				
27	90109-066F0	BOLT	3				

FIG. 1 CYLINDER HEAD



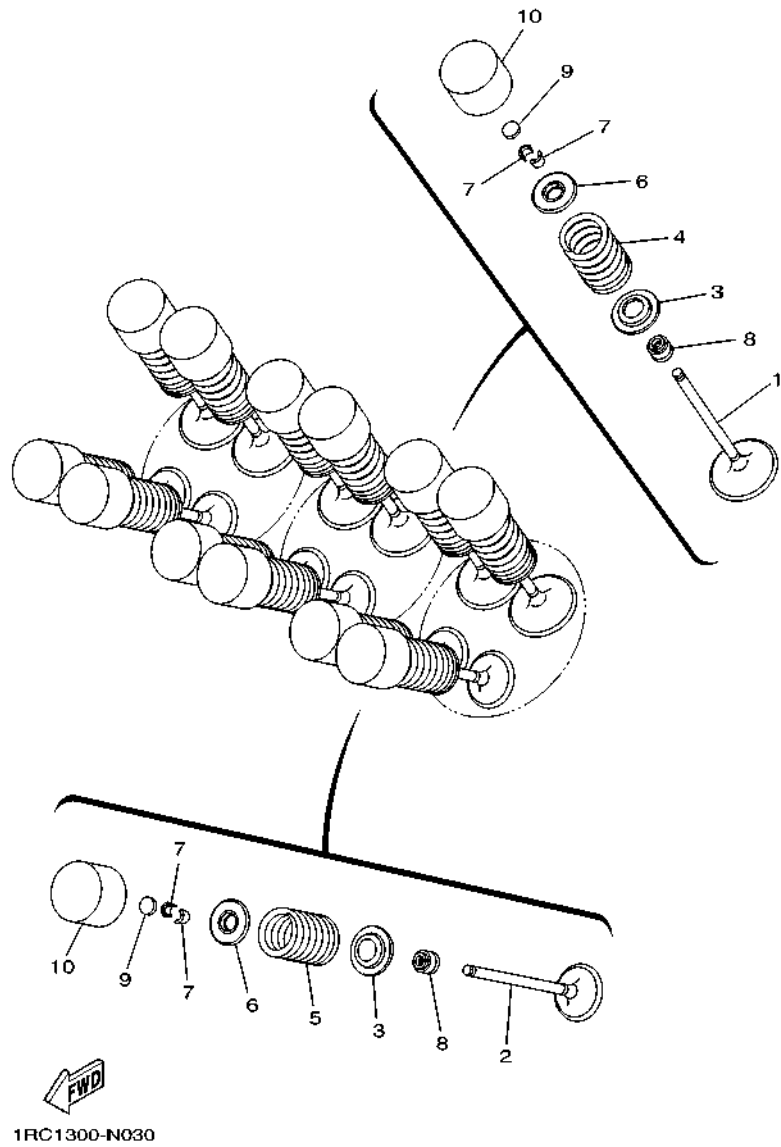
REF. NO.	PART NO.	DESCRIPTION	B2/K2			REMARKS
28	5VY-1111G-00	RUBBER, MOUNT 1	3			
29	90109-06271	BOLT	1			
30	5VY-1111G-00	RUBBER, MOUNT 1	1			
31	99530-12016	PIN, DOWEL	2			
-----						
-----						
-----						
-----						
-----						
-----						
-----						
-----						
-----						



**FIG. 2 CRANKSHAFT & PISTON**

REF. NO.	PART NO.	DESCRIPTION	B2/K2	REMARKS
1	1RC-11400-00	CRANKSHAFT ASSY	1	
2	1RC-11650-01	CONNECTING ROD ASSY	3	
3	1RC-11654-00	.BOLT, CONNECTING ROD	2	
4	1RC-11656-00	PLANE BEARING, CONNECTING ROD	6	UR BLUE
	1RC-11656-10	PLANE BEARING, CONNECTING ROD	6	UR BLACK
	1RC-11656-20	PLANE BEARING, CONNECTING ROD	6	UR BROWN
	1RC-11656-30	PLANE BEARING, CONNECTING ROD	6	UR GREEN
5	5VY-11416-A0	PLANE BEARING, CRANKSHAFT 1	8	UR WHITE
	5VY-11416-00	PLANE BEARING, CRANKSHAFT 1	8	UR BLUE
	5VY-11416-10	PLANE BEARING, CRANKSHAFT 1	8	UR BLACK
	5VY-11416-20	PLANE BEARING, CRANKSHAFT 1	8	UR BROWN
	5VY-11416-30	PLANE BEARING, CRANKSHAFT 1	8	UR GREEN
6	1RC-11631-00	PISTON (STD)	3	
7	1RC-11603-00	PISTON RING SET (STD)	3	
8	39P-11633-00	PIN, PISTON	3	
9	93450-18157	CIRCLIP	6	
10	90280-05029	KEY, WOODRUFF	1	
11	90105-126A8	BOLT, FLANGE	1	
12	90201-12008	WASHER, PLATE	1	
13	1RC-11500-00	BALANCER ASSY	1	
14	2S3-11413-00	METAL, BALANCE WEIGHT	4	UR BLUE
	2S3-11413-10	METAL, BALANCE WEIGHT	4	UR BLACK
	2S3-11413-20	METAL, BALANCE WEIGHT	4	UR BROWN
	2S3-11413-30	METAL, BALANCE WEIGHT	4	UR GREEN
	2S3-11413-40	METAL, BALANCE WEIGHT	4	UR YELLOW

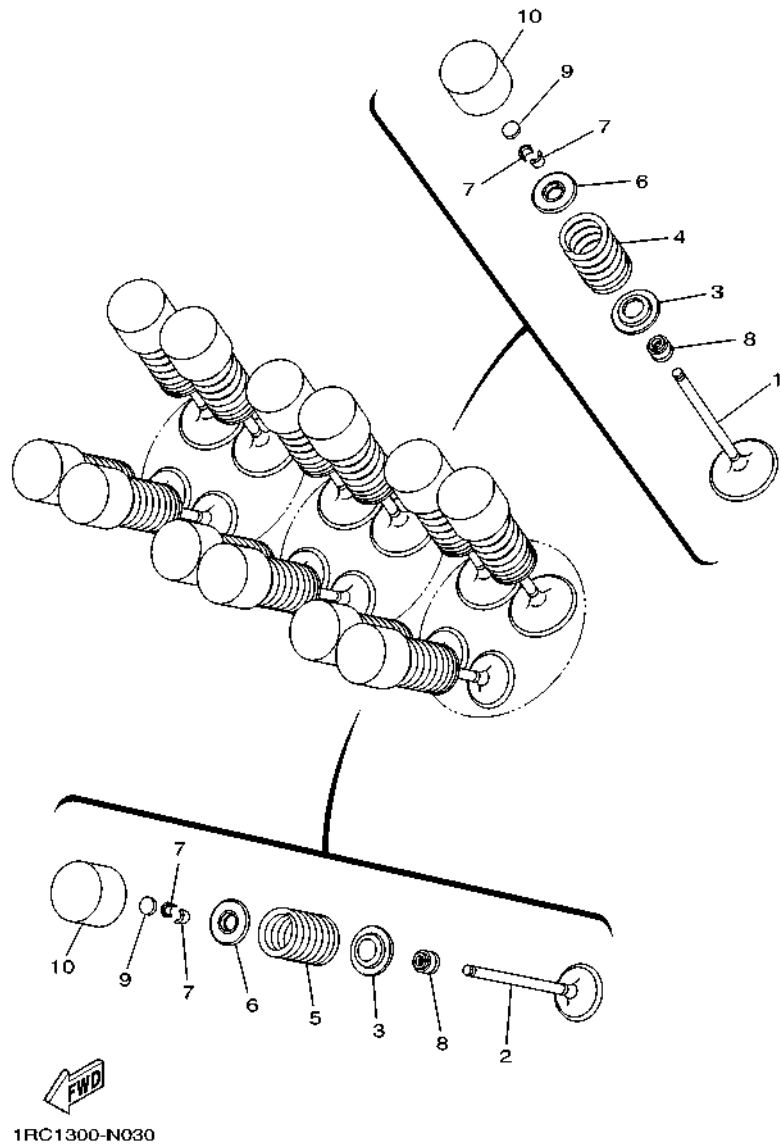




1RC1300-N030

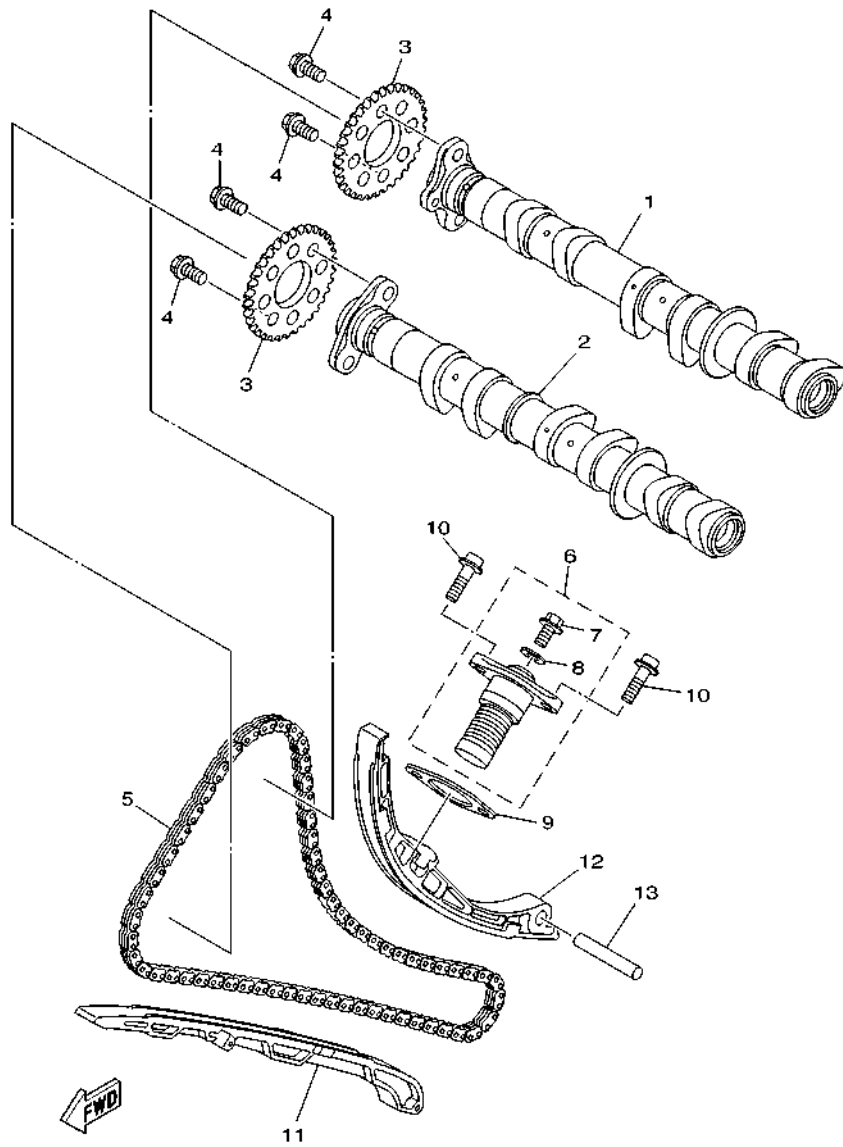
FIG. 3 VALVE

REF. NO.	PART NO.	DESCRIPTION	B2K2	REMARKS
1	1RC-12111-01	VALVE, INTAKE	6	
2	1RC-12121-00	VALVE, EXHAUST	6	
3	1RC-12116-00	SEAT, VALVE SPRING	12	
4	1RC-12113-00	SPRING, VALVE INNER	6	
5	1RC-12114-00	SPRING, VALVE OUTER	6	
6	3D7-12117-00	RETAINER, VALVE SPRING	12	
7	1WG-12118-00	LOCK, VALVE SPRING RETAINER	24	
8	4TE-12119-00	SEAL, VALVE STEM	12	
9	1HX-12168-F0	PAD, ADJUSTING 2 (1.50)	12	UR
	1HX-12168-H1	PAD, ADJUSTING 2 (1.55)	12	UR
	1HX-12168-K1	PAD, ADJUSTING 2 (1.60)	12	UR
	1HX-12168-M1	PAD, ADJUSTING 2 (1.65)	12	UR
	1HX-12168-R1	PAD, ADJUSTING 2 (1.70)	12	UR
	1HX-12168-U1	PAD, ADJUSTING 2 (1.75)	12	UR
	1HX-12168-W1	PAD, ADJUSTING 2 (1.80)	12	UR
	1HX-12168-Y1	PAD, ADJUSTING 2 (1.85)	12	UR
	1HX-12169-11	PAD, ADJUSTING 2 (1.90)	12	UR
	1HX-12169-31	PAD, ADJUSTING 2 (1.95)	12	UR
	1HX-12169-50	PAD, ADJUSTING 2 (2.00)	12	UR
	1HX-12169-70	PAD, ADJUSTING 2 (2.05)	12	UR
	1HX-12169-90	PAD, ADJUSTING 2 (2.10)	12	UR
	1HX-12169-E0	PAD, ADJUSTING 2 (2.15)	12	UR
	1HX-12169-G0	PAD, ADJUSTING 2 (2.20)	12	UR
	1HX-12169-J0	PAD, ADJUSTING 2 (2.25)	12	UR
	1HX-12169-L0	PAD, ADJUSTING 2 (2.30)	12	UR
	1HX-12169-N0	PAD, ADJUSTING 2 (2.35)	12	UR
	1HX-12169-T0	PAD, ADJUSTING 2 (2.40)	12	UR



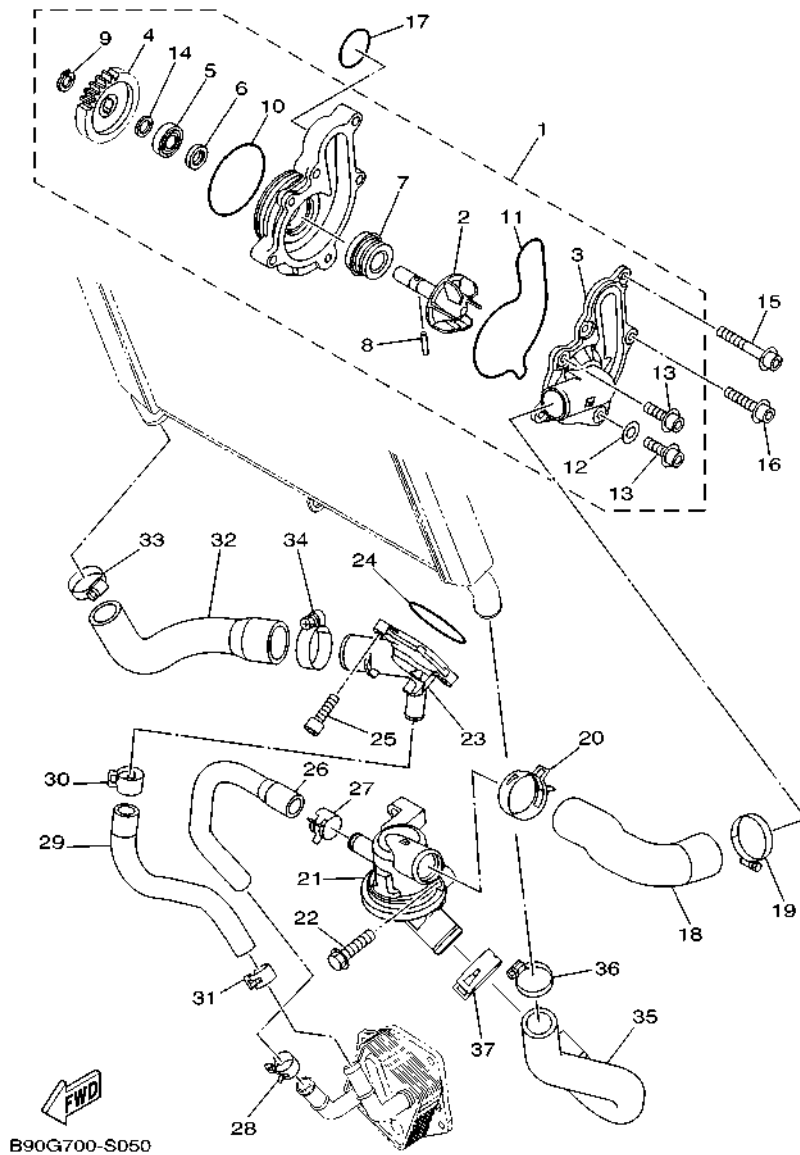
**FIG. 3 VALVE**

REF. NO.	PART NO.	DESCRIPTION	B2/K2				REMARKS
10	4C8-12153-10	LIFTER, VALVE	12				YELLOW
	4C8-12153-09	LIFTER, VALVE (O/S)	12				AP GREEN



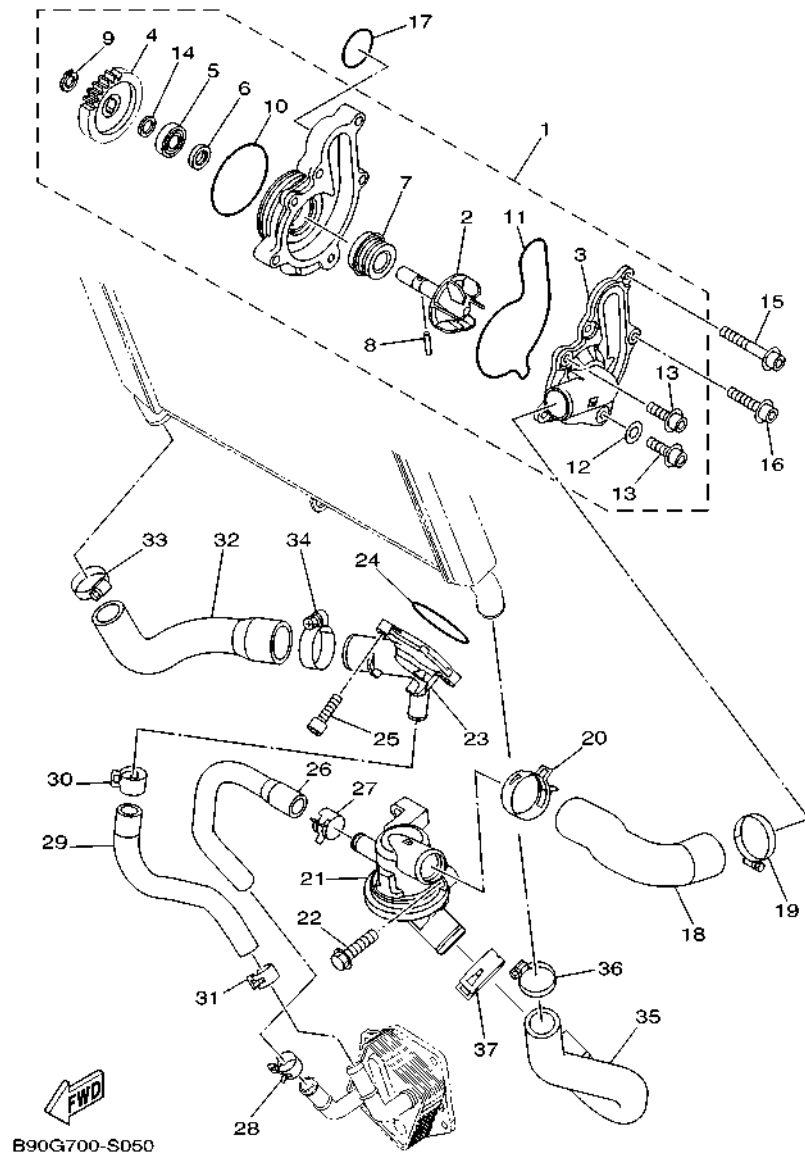
**FIG. 4 CAMSHAFT & CHAIN**

REF. NO.	PART NO.	DESCRIPTION	B2/K2				REMARKS
1	1RC-12170-00	CAMSHAFT ASSY 1	1				
2	1RC-12180-00	CAMSHAFT ASSY 2	1				
3	20S-12176-00	SPROCKET, CAM CHAIN	2				
4	90105-07006	BOLT, FLANGE	4				
5	94591-57128	CHAIN (98XRH2010-128M)	1				
6	B90-12210-00	TENSIONER ASSY, CAM CHAIN	1				
7	5EL-12228-00	.BOLT	1				
8	5SL-12214-00	.GASKET	1				
9	1WS-12213-00	GASKET, TENSIONER CASE	1				
10	90110-06395	BOLT, HEXAGON SOCKET HEAD	2				
11	1RC-12251-00	DAMPER, CHAIN 1	1				
12	1RC-12250-01	CHAIN DAMPER ASSY	1				
13	93607-44002	PIN, DOWEL	1				



**FIG. 5 WATER PUMP**

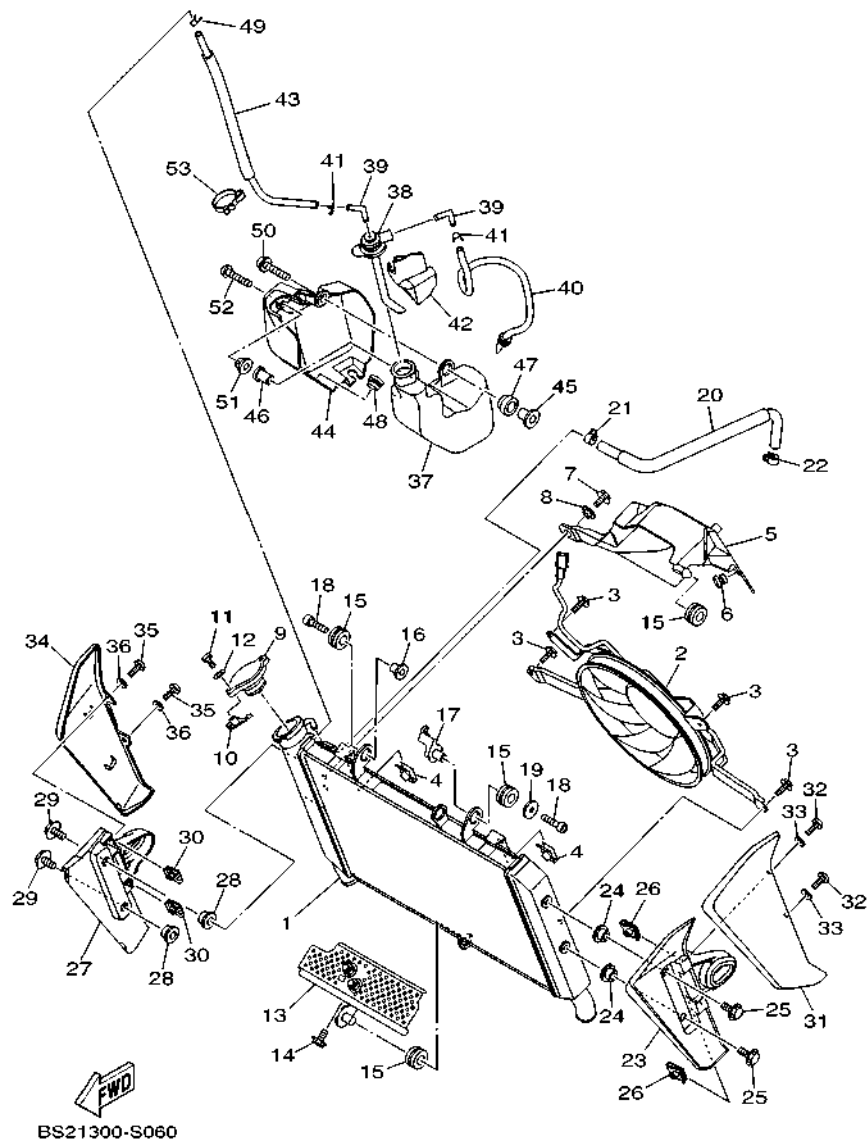
REF. NO.	PART NO.	DESCRIPTION	B2K2				REMARKS
1	1RC-12420-00	WATER PUMP ASSY	1				
2	1RC-12450-00	.IMPELLER SHAFT ASSY	1				
3	1RC-12422-00	.COVER, HOUSING	1				
4	1RC-12459-00	.GEAR, IMPELLER SHAFT	1				
5	93306-00106	.BEARING	1				
6	93101-12173	.OIL SEAL	1				
7	5VK-12438-00	.SEAL, MECHANICAL	1				
8	93603-16219	.PIN, DOWEL	1				
9	99009-12400	.CIRCLIP	1				
10	93210-61750	.O-RING	1				
11	1RC-12439-00	.O-RING	1				
12	90430-06014	.GASKET	1				
13	90110-06396	.BOLT, HEXAGON SOCKET HEAD	2				
14	90201-12541	.WASHER, PLATE	1				
15	90110-06394	BOLT, HEXAGON SOCKET HEAD	3				
16	90110-06388	BOLT, HEXAGON SOCKET HEAD	1				
17	93210-30694	O-RING	1				
18	1RC-12577-00	HOSE 2	1				
19	90450-38040	HOSE CLAMP ASSY	1				
20	90467-310A0	CLIP	1				
21	1RC-12410-00	THERMOSTAT ASSY	1				
22	95822-06025	BOLT, FLANGE	2				
23	1RC-12469-00	JOINT 1	1				
24	93210-46044	O-RING	1				
25	90110-06274	BOLT, HEXAGON SOCKET HEAD	2				
26	BS2-12578-00	HOSE 3	1				
27	90467-21068	CLIP	1				



**FIG. 5 WATER PUMP**

REF. NO.	PART NO.	DESCRIPTION	B2/K2				REMARKS
28	90467-200A0	CLIP	1				
29	BS2-12579-00	HOSE 4	1				
30	90467-22002	CLIP	1				
31	90467-200A0	CLIP	1				
32	1RC-12588-00	HOSE 5	1				
33	90450-32003	HOSE CLAMP ASSY	1				
34	90450-38040	HOSE CLAMP ASSY	1				
35	1RC-12576-00	HOSE 1	1				
36	90450-32003	HOSE CLAMP ASSY	1				
37	90467-310A0	CLIP	1				

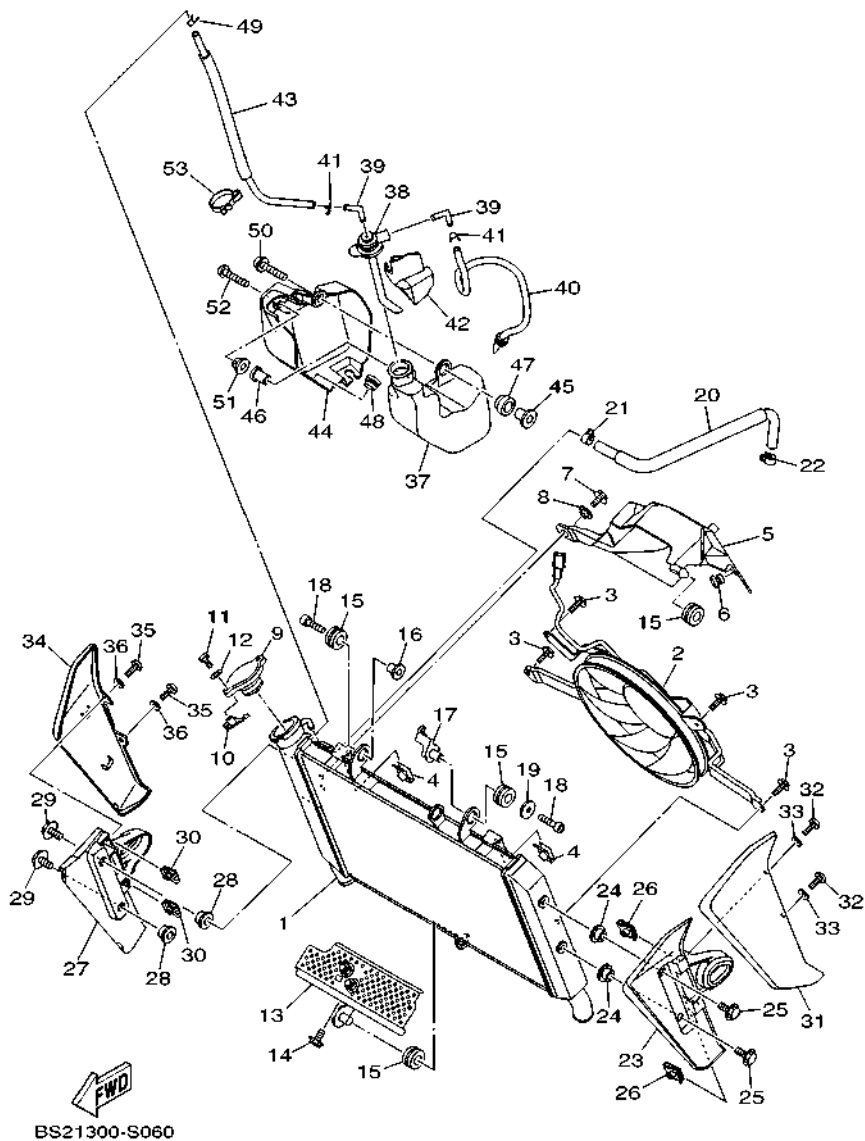
**FIG. 6 RADIATOR & HOSE**



BS21300-S060

REF. NO.	PART NO.	DESCRIPTION	B2/K2				REMARKS
1	2PP-12461-00	RADIATOR COMP	1				
2	1RC-12405-01	BLOWER ASSY	1				
3	3D8-12675-00	BOLT, BLOWER HOLDING	4				
4	1AA-12535-00	PLATE	2				
5	1RC-12467-00	COVER, RADIATOR	1				
6	90338-07157	PLUG	1				
7	90105-06080	BOLT, FLANGE	1				
8	90387-07717	COLLAR	1				
9	4FL-12462-00	CAP, RADIATOR	1				
10	5FC-12437-00	STOPPER	1				
11	97007-05012	BOLT	1				
12	92907-05600	WASHER, PLATE	1				
13	BS2-12637-00	STAY 1	1				
14	95D32-06012	BOLT, FLANGE DEEP RECESS	1				
15	90480-15363	GROMMET	4				
16	90387-06158	COLLAR	1				
17	1RC-26132-00	GUIDE, CABLE 2	1				
18	91312-06030	BOLT, HEXAGON SOCKET HEAD	2				
19	90201-06033	WASHER, PLATE	1				
20	1RC-1243A-00	HOSE 1	1				
21	90467-10039	CLIP	1				
22	90467-10039	CLIP	1				
23	BS2-2175T-00	BRACKET 1	1				
24	90387-06170	COLLAR	2				
25	90119-06137	BOLT, WITH WASHER	2				
26	90183-05076	NUT, SPRING	2				
27	BS2-2175U-00	BRACKET 2	1				

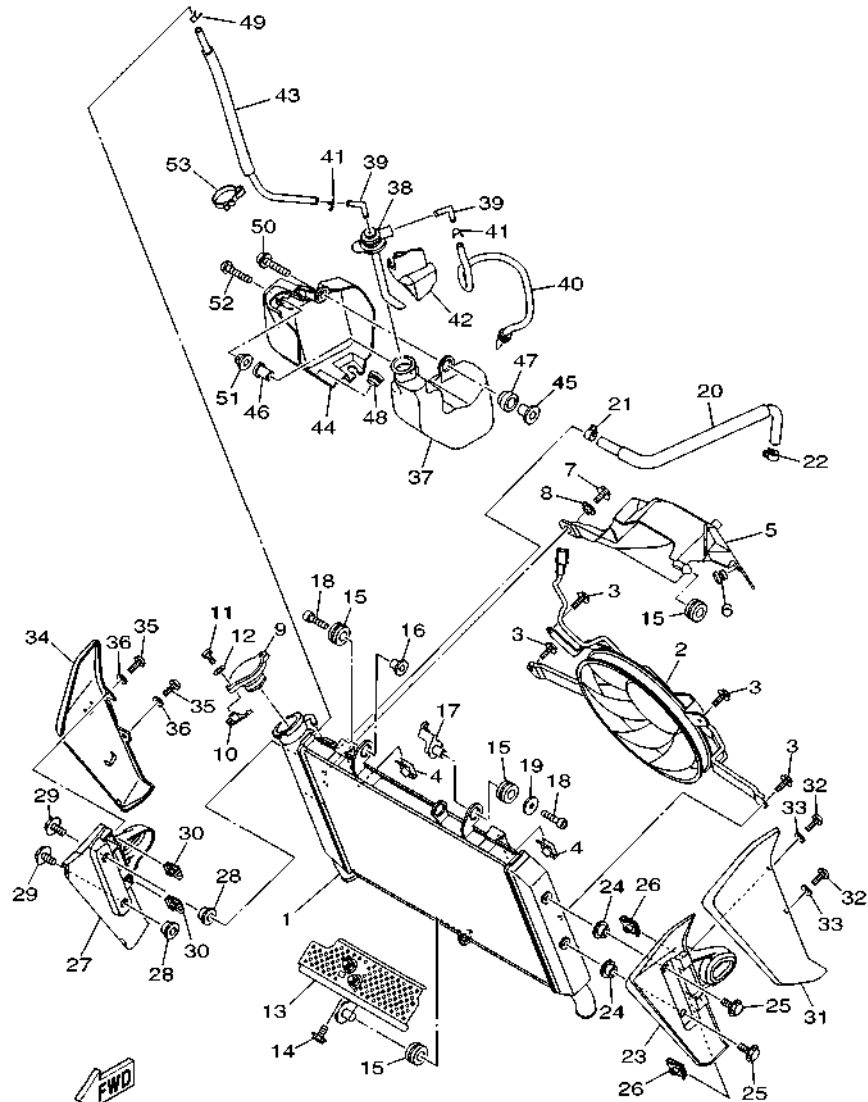
**FIG. 6 RADIATOR & HOSE**



BS21300-S060

REF. NO.	PART NO.	DESCRIPTION	B2K2				REMARKS
28	90387-06170	COLLAR	2				
29	90119-06137	BOLT, WITH WASHER	2				
30	90183-05076	NUT, SPRING	2				
31	BS2-2171E-00-33	COVER, SIDE 5	1				UR YB FOR DPBMC
	BS2-2171E-00-P6	COVER, SIDE 5	1				UR FOR MLNM4
32	90111-05002	BOLT,HEX. SOCKET BUTTON	2				
33	90202-05180	WASHER, PLATE	2				
34	BS2-2171X-00-33	COVER, SIDE 6	1				UR YB FOR DPBMC
	BS2-2171X-00-P6	COVER, SIDE 6	1				UR FOR MLNM4
35	90111-05002	BOLT,HEX. SOCKET BUTTON	2				
36	90202-05180	WASHER, PLATE	2				
37	1RC-21871-00	TANK, RECOVERY	1				
38	1RC-21875-00	CAP	1				
39	1RC-21828-00	ELBOW	2				
40	1RC-21826-00	PIPE, BREATHER	1				
41	90467-08075	CLIP	2				
42	1RC-22825-00	PROTECTOR 1	1				
43	1RC-21816-00	PIPE 1	1				
44	1RC-2172W-00	COVER	1				
45	90387-06285	COLLAR	1				
46	90179-05523	NUT	1				
47	1RC-21749-00	COLLAR	1				
48	90480-13203	GROMMET	1				
49	90467-08075	CLIP	1				
50	90110-06233	BOLT, HEXAGON SOCKET HEAD	1				
51	1RC-21748-00	COLLAR	1				
52	92012-05030	BOLT, BUTTON HEAD	1				

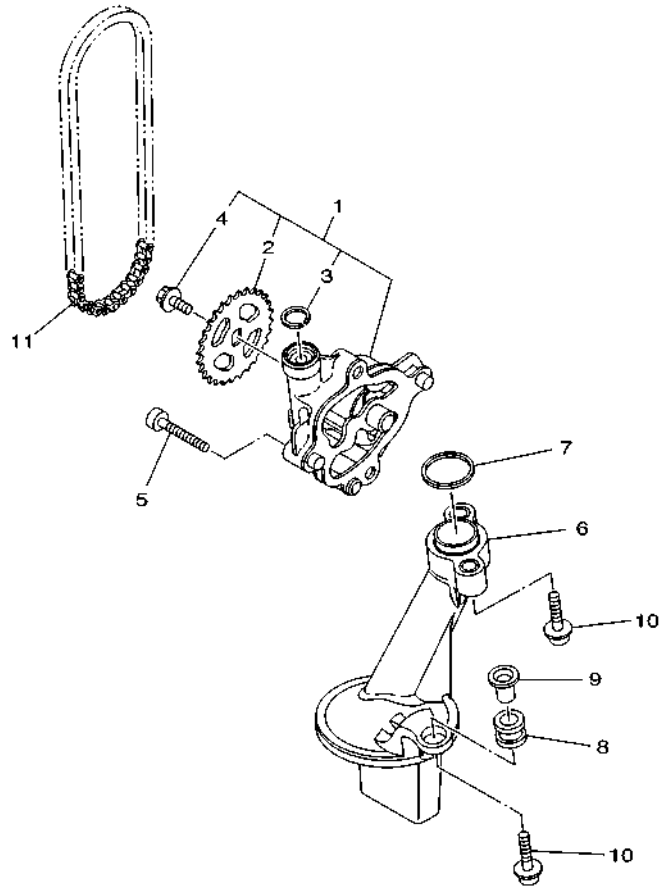
FIG. 6 RADIATOR & HOSE



BS21300-S060

REF. NO.	PART NO.	DESCRIPTION	B2/K2				REMARKS
53	90464-07M40	CLAMP	1				

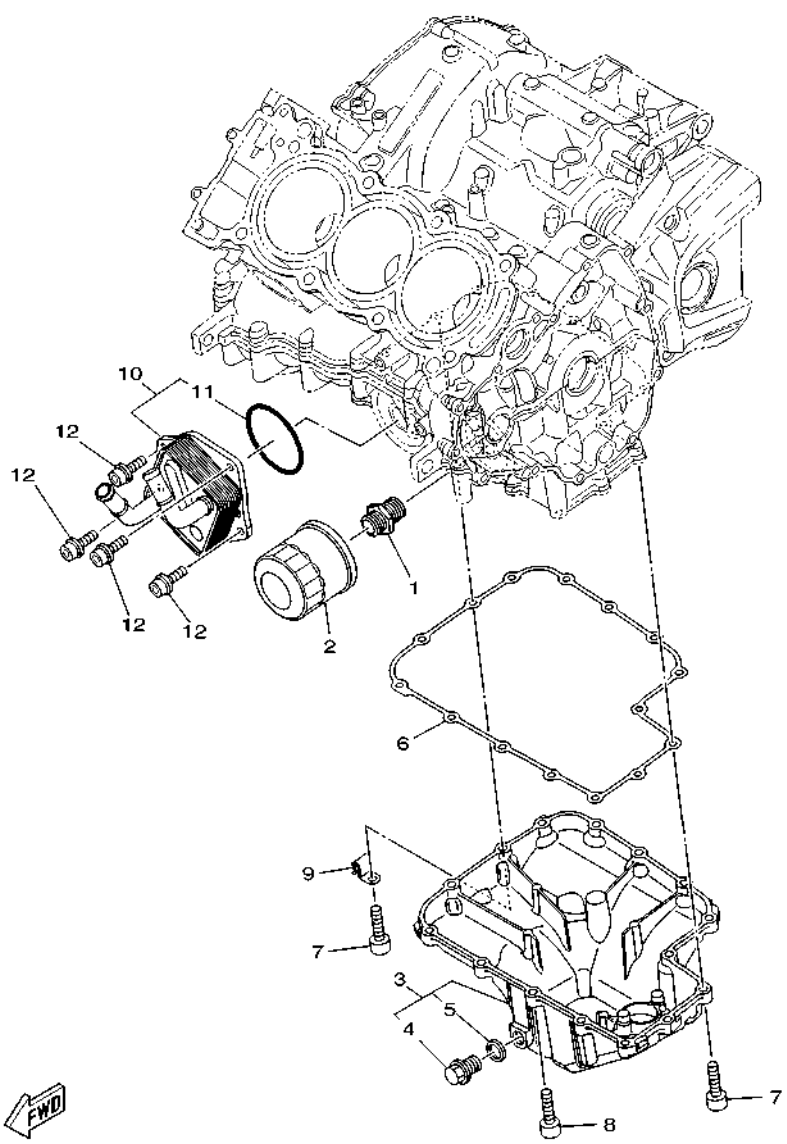




  
 1RC1300-N070

**FIG. 7 OIL PUMP**

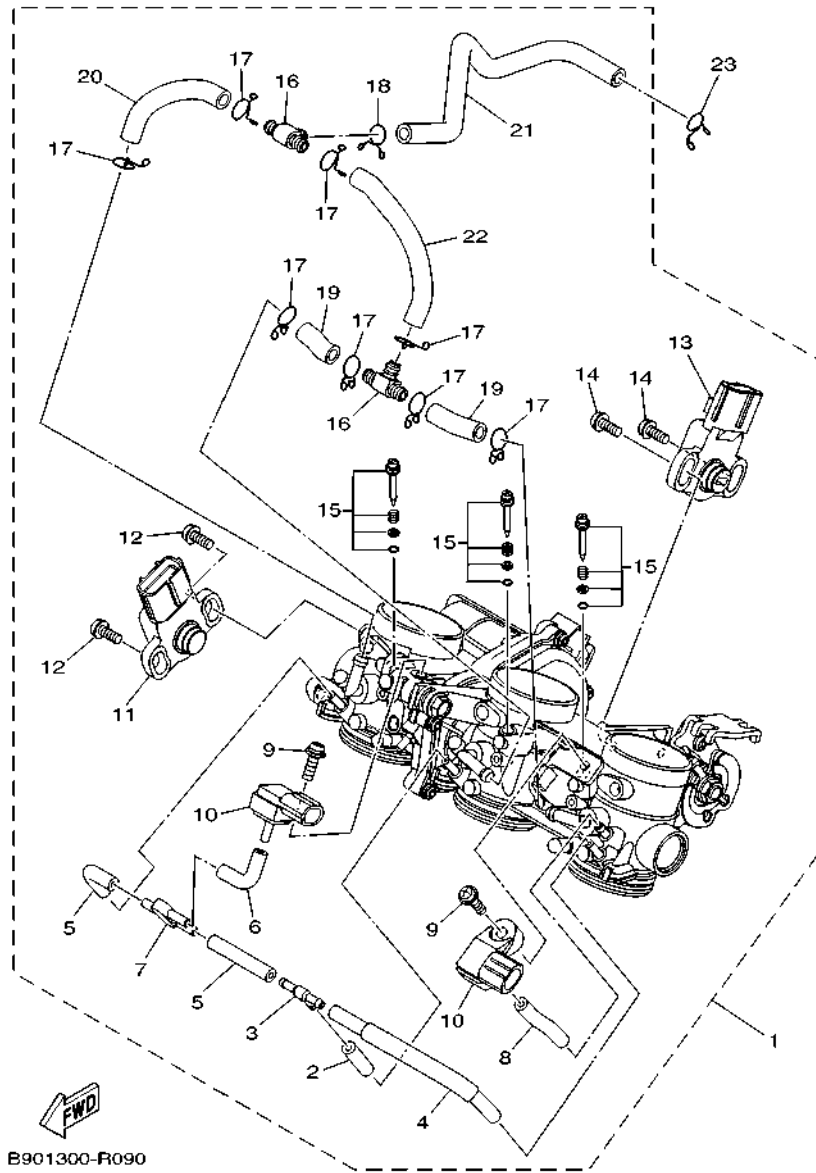
REF. NO.	PART NO.	DESCRIPTION	B2/K2				REMARKS
1	1RC-13300-00	OIL PUMP ASSY	1				
2	1RC-13355-00	.SPROCKET, DRIVEN	1				
3	99009-15500	.CIRCLIP	1				
4	90105-06066	.BOLT, FLANGE	1				
5	91312-06035	BOLT, HEXAGON SOCKET HEAD	4				
6	1RC-13410-00	STRAINER HOUSING ASSY	1				
7	93210-22001	O-RING	1				
8	90480-13010	GROMMET	1				
9	5VY-13117-10	COLLAR, DISTANCE	1				
10	90110-06173	BOLT, HEXAGON SOCKET HEAD	3				
11	94581-79066	CHAIN (DID 25H)	1				



B90G700-S080

FIG. 8 OIL CLEANER

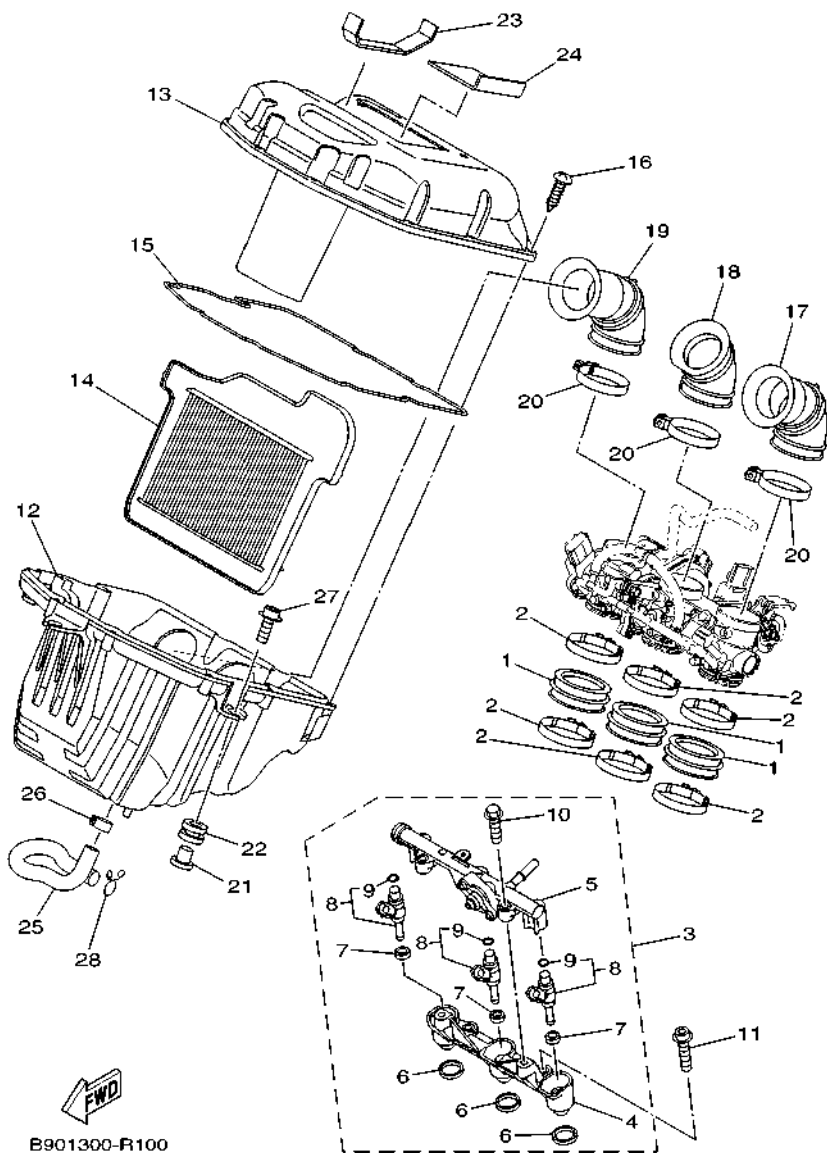
REF. NO.	PART NO.	DESCRIPTION	B2K2				REMARKS
1	90401-20011	BOLT, UNION	1				
2	5GH-13440-60	ELEMENT ASSY, OIL CLEANER	1				
3	B56-13400-10	STRAINER COVER ASSY	1				
4	90340-14132	.PLUG, STRAIGHT SCREW	1				
5	214-11198-01	.GASKET	1				
6	BD5-13414-00	GASKET, STRAINER COVER	1				
7	91312-06025	BOLT, HEXAGON SOCKET HEAD	14				
8	90110-06169	BOLT, HEXAGON SOCKET HEAD	1				
9	90465-06025	CLAMP	1				
10	BS2-13470-00	OIL COOLER ASSY	1				
11	2HC-13473-00	.O-RING	1				
12	90110-06164	BOLT, HEXAGON SOCKET HEAD	4				



**FIG. 9 INTAKE**

REF. NO.	PART NO.	DESCRIPTION	B2K2				REMARKS
1	B90-13750-00	THROTTLE BODY ASSY	1				
2	1RC-13544-00	.HOSE, VACUUM SENSING 2	1				
3	68V-24376-00	.PIPE, JOINT 1	1				
4	1RC-13542-00	.HOSE, VACUUM SENSING 1	1				
5	8FP-14349-20	.PIPE	2				
6	8FP-14349-00	.PIPE	1				
7	3XV-14251-00	.NIPPLE	1				
8	8FP-14349-30	.PIPE	1				
9	2C0-14216-00	.SCREW	2				
10	1WS-82380-00	.SENSOR, PRESSURE	2				
11	13S-85885-00	.THROTTLE SENSOR ASSY	1				
12	8CC-14216-10	.SCREW	2				
13	1MC-85884-00	.ACCELERATOR SENSOR ASSY	1				
14	5FL-14216-00	.SCREW	2				
15	2C0-14105-00	.PILOT SCREW SET	3				
16	90413-06031	.WAY 3	2				
17	90467-100A1	.CLIP	8				
18	90467-09103	.CLIP	1				
19	B50-14465-00	.PIPE	2				
20	60L-24321-00	.PIPE 10	1				
21	B90-1443J-00	.PIPE	1				
22	B50-1444J-00	.PIPE	1				
23	90467-09006	CLIP	1				

**FIG. 10 INTAKE 2**

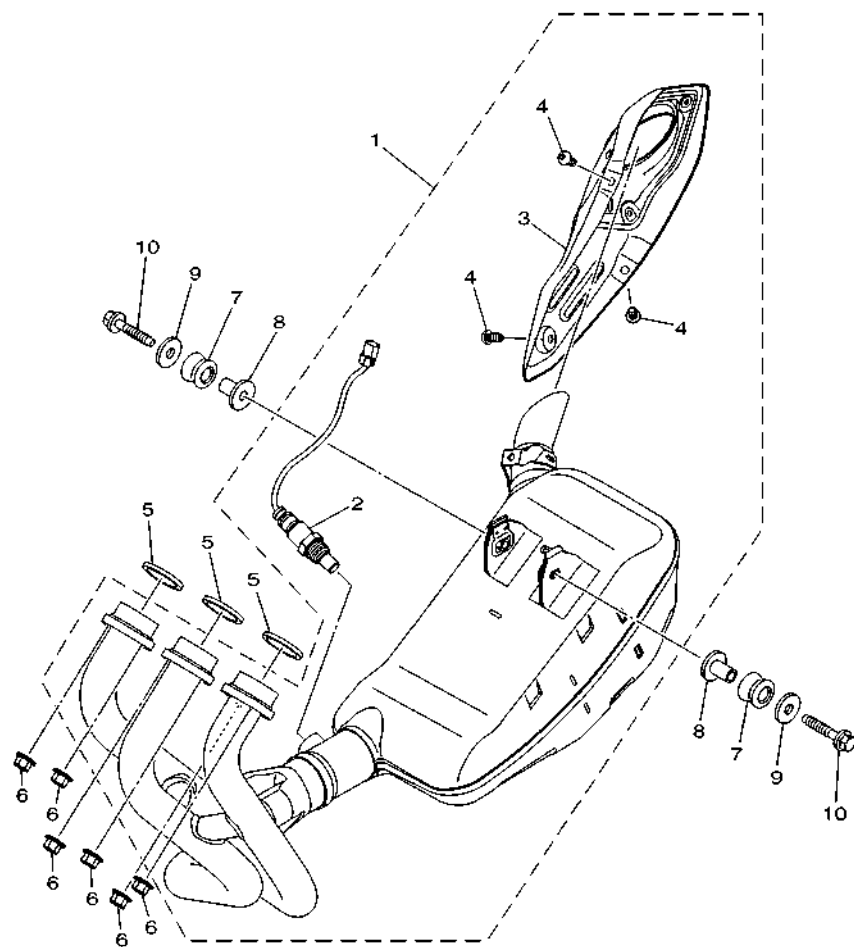


REF. NO.	PART NO.	DESCRIPTION	B2K2	REMARKS
1	1RC-13635-00	JOINT, INTAKE 1	3	
2	90450-56009	HOSE CLAMP ASSY	6	
3	1RC-13930-00	PIPE INLET ASSEMBLY	1	
4	1RC-12572-00	.ADAPTER	1	
5	1RC-13938-00	.PIPE	1	
6	1RC-13556-00	.GASKET, MANIFOLD	3	
7	8FP-13556-00	.RUBBER, INJECTOR	3	
8	4C8-13761-00	.INJECTOR	3	
9	5PS-14147-00	..O-RING	1	
10	1RC-13573-00	.BOLT 1	2	
11	90110-06388	BOLT, HEXAGON SOCKET HEAD	2	
12	1RC-14411-00	CASE, AIR CLEANER 1	1	
13	1RC-14421-20	CASE, AIR CLEANER 2	1	
14	1RC-14451-00	ELEMENT, AIR CLEANER	1	
15	1RC-14452-00	SEAL	1	
16	90160-05013	SCREW, ROUND TAPPING	10	
17	1RC-14453-00	JOINT, AIR CLEANER 1	1	
18	1RC-14463-00	JOINT, AIR CLEANER 2	1	
19	1RC-14454-00	JOINT	1	
20	90450-53007	HOSE CLAMP ASSY	3	
21	90387-06205	COLLAR	3	
22	90480-12314	GROMMET	3	
23	1RC-14425-00	DAMPER 1	1	
24	1RC-14426-00	DAMPER 2	1	
25	1RC-15393-00	PIPE, BREATHER 2	1	
26	90467-15001	CLIP	1	
27	90110-06233	BOLT, HEXAGON SOCKET HEAD	3	





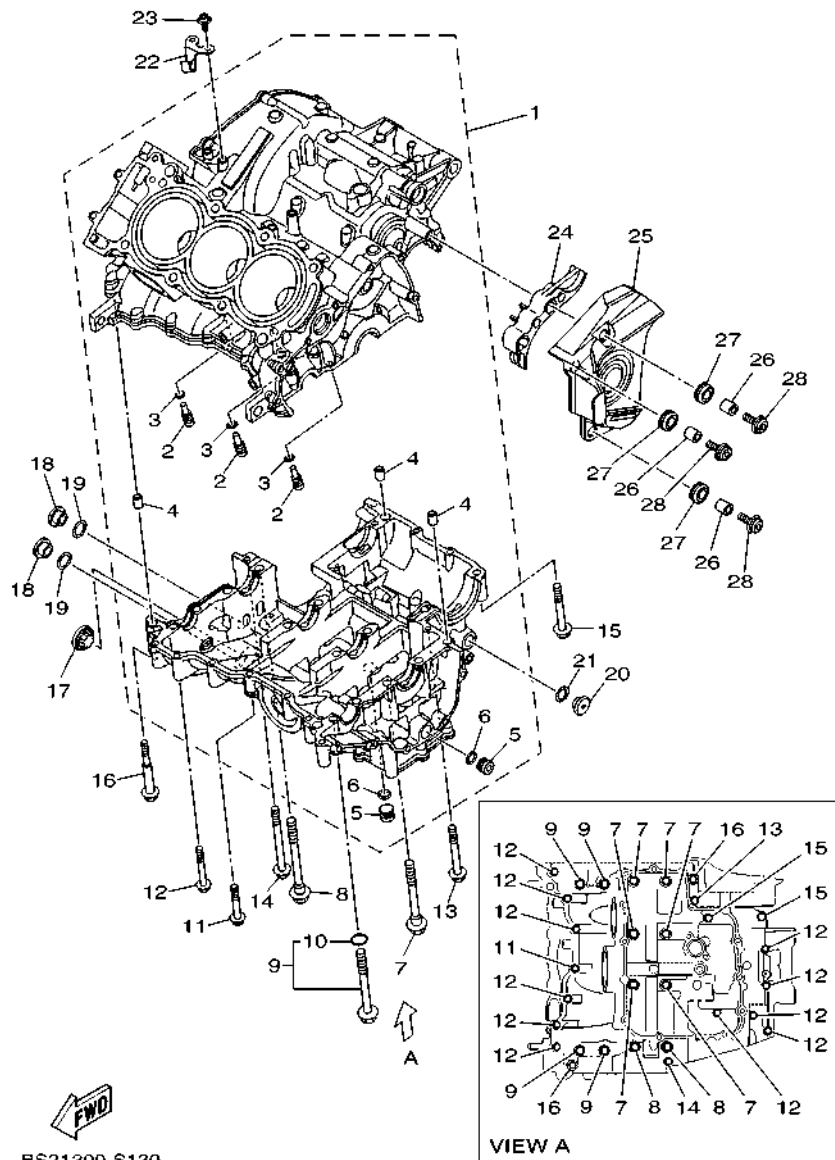
**FIG. 12 EXHAUST**



**FWD**  
BS21300-S120

REF. NO.	PART NO.	DESCRIPTION	B2/K2				REMARKS
1	BS2-14710-00	MUFFLER ASSY 1	1				
2	59C-8592A-00	.SENSOR, OXYGEN	1				
3	BS2-14708-00	.PROTECTOR ASSY	1				
4	90111-06169	.BOLT,HEX. SOCKET BUTTON	3				
5	4FM-14613-00	GASKET, EXHAUST PIPE	3				
6	90179-08410	NUT	6				
7	5VY-14747-00	DAMPER, MUFFLER	2				
8	90387-08021	COLLAR	2				
9	90201-087G2	WASHER, PLATE	2				
10	90109-08170	BOLT	2				

FIG. 13 CRANKCASE



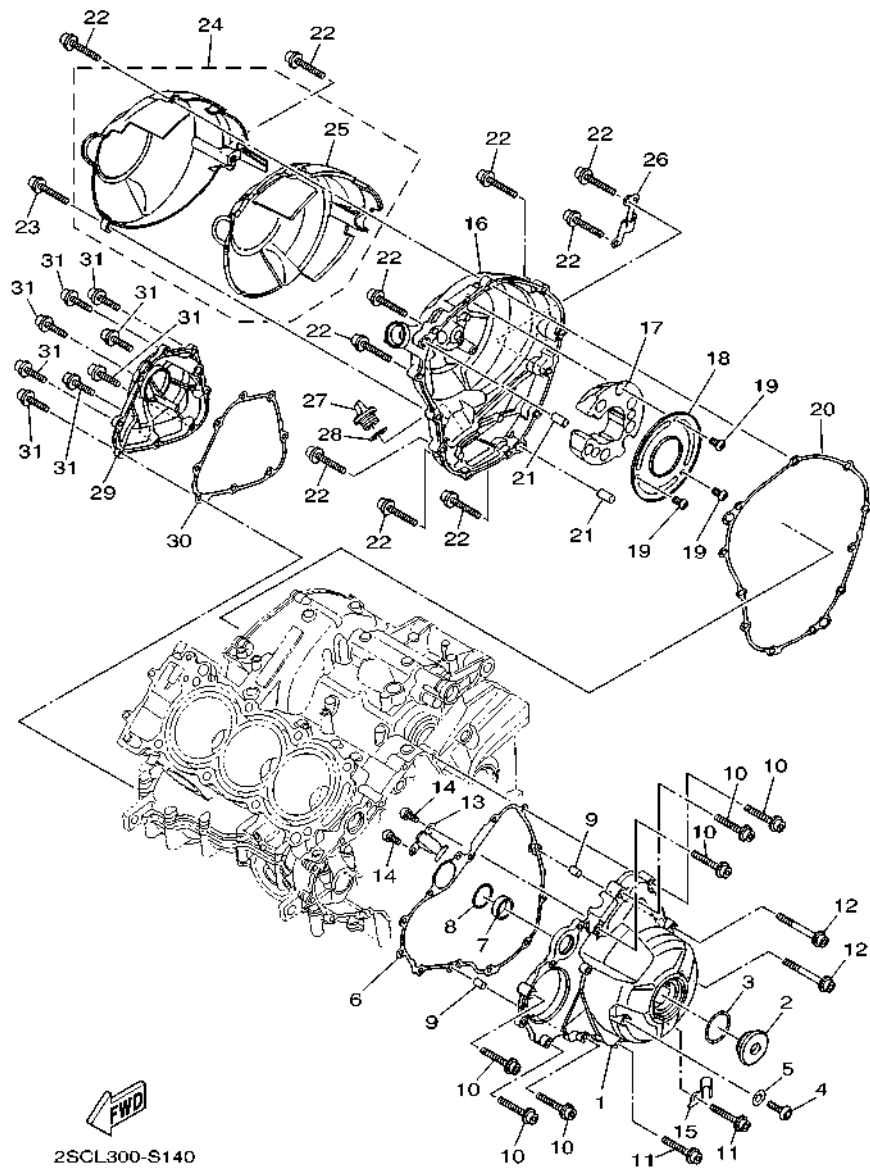
BS21300-S130

REF. NO.	PART NO.	DESCRIPTION	B2K2	REMARKS
1	BS2-15100-09	CRANKCASE ASSY	1	
2	5EB-15155-00	.NOZZLE 3	3	
3	93210-04092	.O-RING	3	
4	99530-10014	.PIN, DOWEL	3	
5	90338-16262	.PLUG	2	
6	93210-12790	.O-RING	2	
7	90119-09013	BOLT, WITH WASHER	6	
8	90119-09010	BOLT, WITH WASHER	2	
9	23P-15156-00	BOLT, CRANKCASE JOURNAL	4	
10	93210-07540	.O-RING	1	
11	95812-06040	BOLT, FLANGE	1	
12	95812-06050	BOLT, FLANGE	11	
13	95812-06065	BOLT, FLANGE	1	
14	90105-06202	BOLT, FLANGE	1	
15	95812-08060	BOLT, FLANGE	2	
16	90109-06100	BOLT	2	
17	2H7-15361-00	GAUGE, LEVEL	1	
18	36Y-15189-00	PLUG	2	
19	93210-16325	O-RING	2	
20	90340-14011	PLUG, STRAIGHT SCREW	1	
21	93210-14369	O-RING	1	
22	1RC-15441-00	HOLDER, CLUTCH CABLE	1	
23	90110-06108	BOLT, HEXAGON SOCKET HEAD	2	
24	1RC-15377-00	GUIDE, INLET	1	
25	BS2-15418-00	COVER, CHAIN CASE	1	
26	90387-06286	COLLAR	3	
27	90480-13018	GROMMET	3	





FIG. 14 CRANKCASE COVER 1



2SCL300-S140

REF. NO.	PART NO.	DESCRIPTION	B2/K2				REMARKS
1	1RC-15411-01	COVER, CRANKCASE 1	1				
2	90340-36005	PLUG, STRAIGHT SCREW	1				
3	93210-357A3	O-RING	1				
4	92017-08012	BOLT, BUTTON HEAD	1				
5	90430-08143	GASKET	1				
6	BD5-15451-00	GASKET, CRANKCASE COVER 1	1				
7	1RC-12564-00	PIPE, WATER	1				
8	93210-28543	O-RING	1				
9	99530-08012	PIN, DOWEL	2				
10	90110-06388	BOLT, HEXAGON SOCKET HEAD	6				
11	90110-06389	BOLT, HEXAGON SOCKET HEAD	2				
12	90110-06394	BOLT, HEXAGON SOCKET HEAD	2				
13	1RC-15484-00	CLAMP 2	1				
14	90110-06168	BOLT, HEXAGON SOCKET HEAD	2				
15	1RC-15199-00	BRACKET	1				
16	1RC-15421-11	COVER, CRANKCASE 2	1				
17	B90-15316-00	DAMPER 1	1				
18	B90-15492-00	COVER	1				
19	90149-06158	SCREW	3				
20	1RC-15461-00	GASKET, CRANKCASE COVER 2	1				
21	93610-20189	PIN, DOWEL	2				
22	90110-06388	BOLT, HEXAGON SOCKET HEAD	10				
23	90110-06321	BOLT, HEXAGON SOCKET HEAD	1				
24	BS2-15490-00	COVER ASSY	1				
25	B90-15326-00	.DAMPER 2	1				
26	1RC-15191-00	PLATE	1				
27	5GJ-15363-10	PLUG, OIL	1				

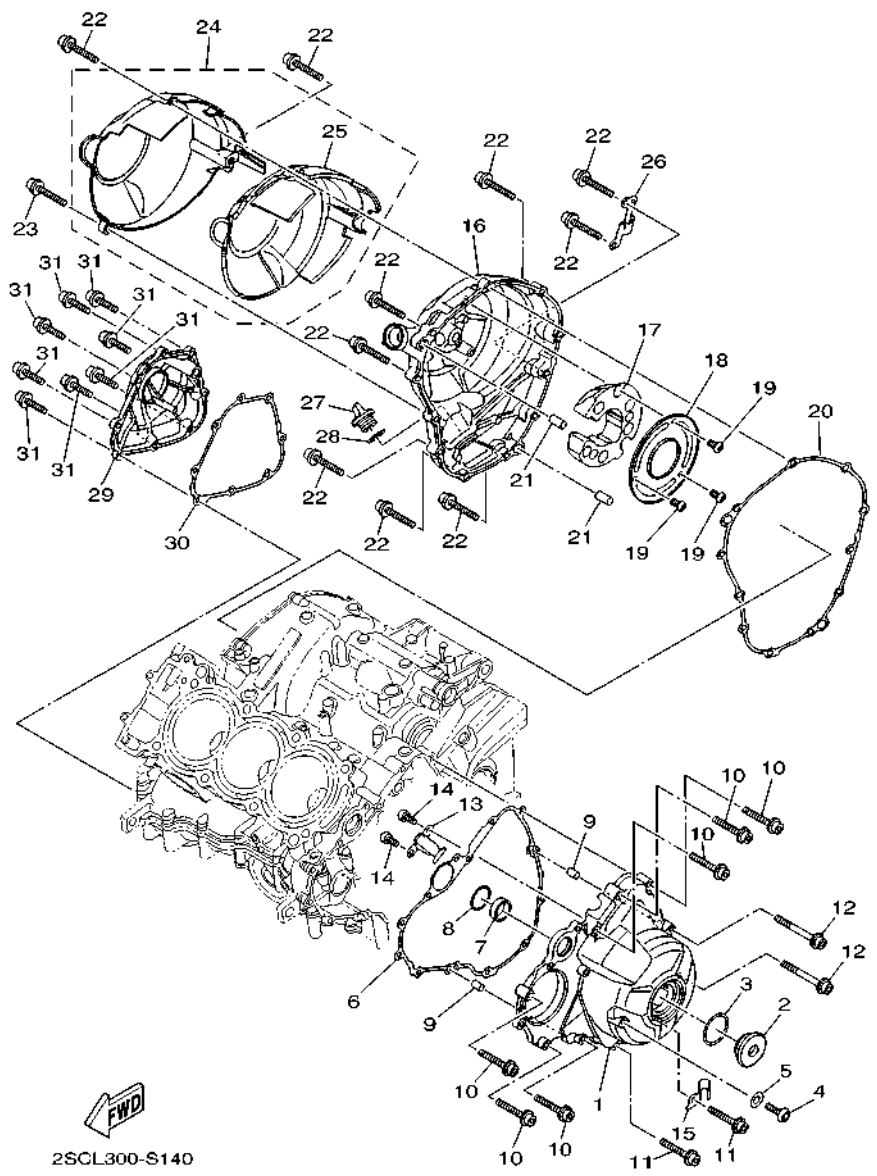
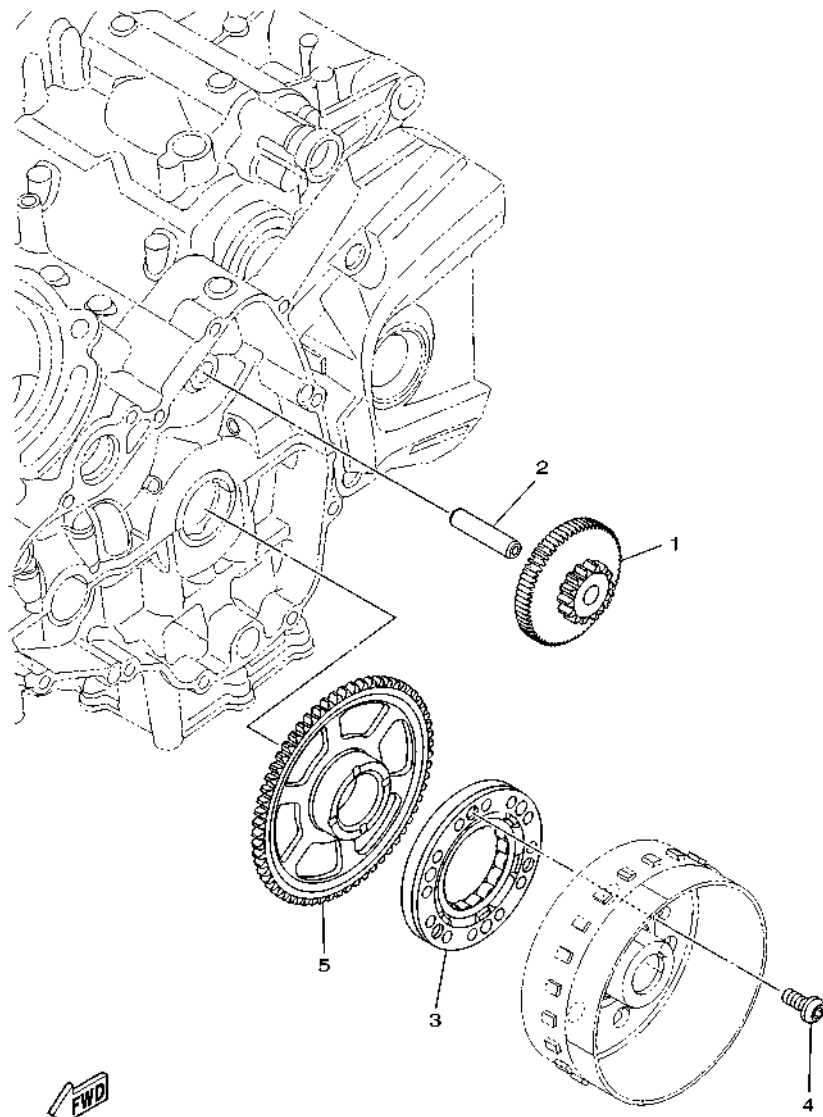


FIG. 14 CRANKCASE COVER 1

REF. NO.	PART NO.	DESCRIPTION	B2/K2					REMARKS
28	93210-19123	O-RING	1					
29	1RC-15416-00	COVER, OIL PUMP	1					
30	1RC-15456-00	GASKET, OIL PUMP COVER 1	1					
31	90110-06396	BOLT, HEXAGON SOCKET HEAD	8					
-----								
-----								
-----								
-----								
-----								
-----								
-----								
-----								
-----								
-----								



1RC1300-N150

FIG. 15 STARTER

REF. NO.	PART NO.	DESCRIPTION	B2/K2					REMARKS
1	1RC-15512-00	GEAR, IDLER 1	1					
2	5EB-15521-00	SHAFT 1	1					
3	1RC-15590-00	STARTER ONE-WAY ASSY	1					
4	90149-08030	SCREW	3					
5	1RC-15515-00	GEAR 3	1					

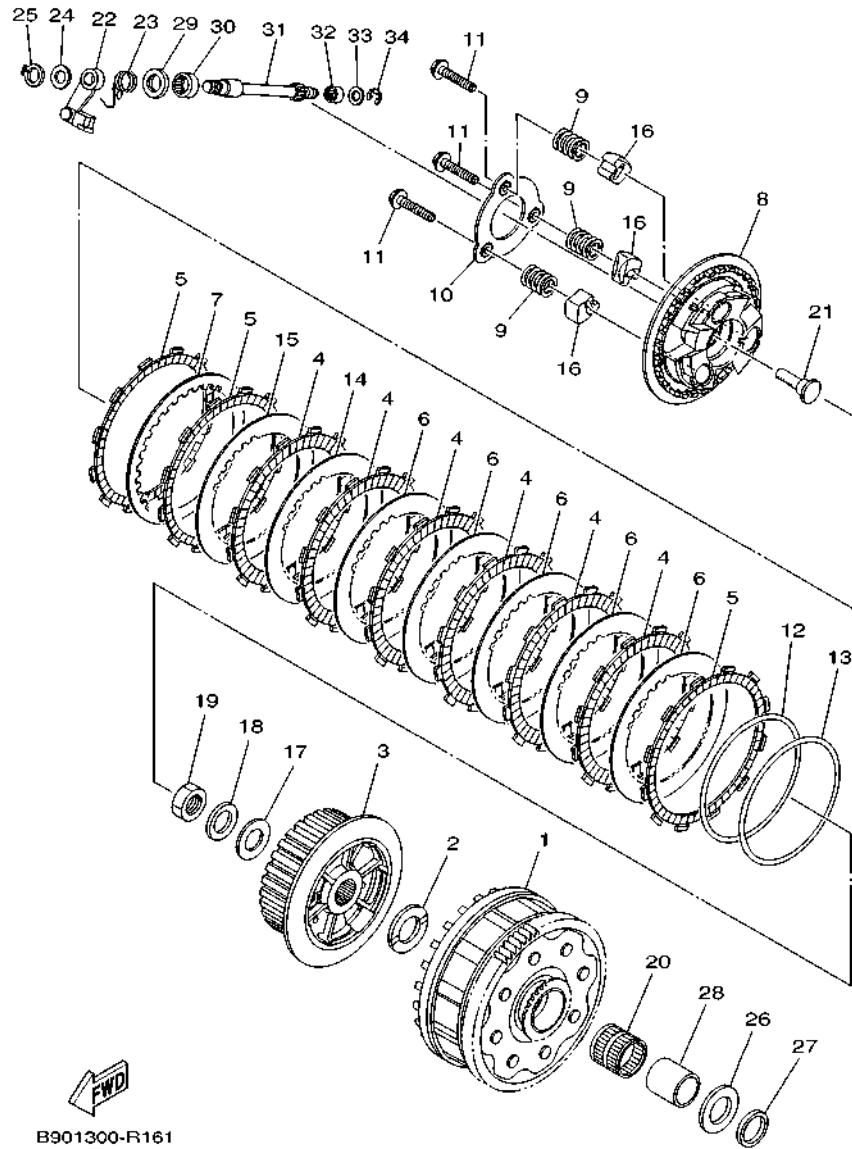
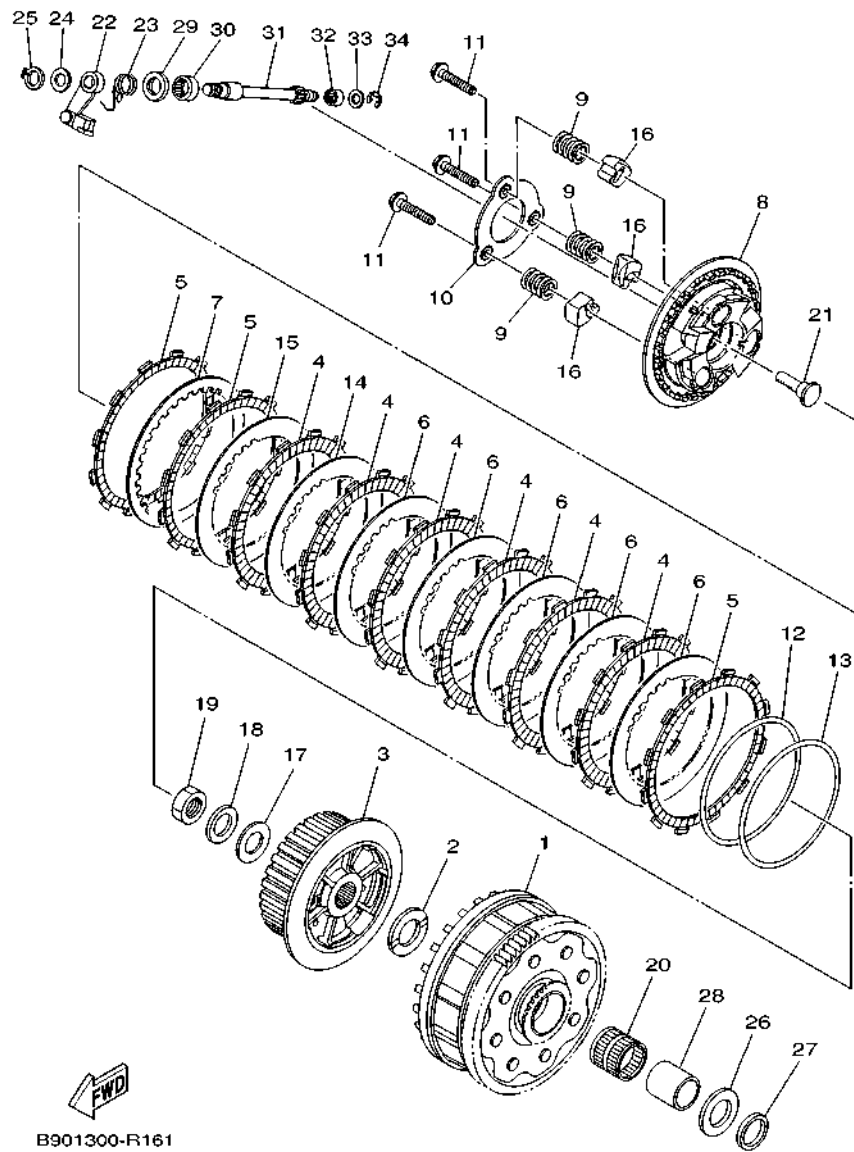


FIG. 16 CLUTCH

REF. NO.	PART NO.	DESCRIPTION	B2K2	REMARKS
1	1RC-16150-00	PRIMARY DRIVEN GEAR COMP.	1	
2	5VY-16154-00	PLATE, THRUST 1	1	
3	B90-16371-10	BOSS, CLUTCH	1	
4	5TA-16321-00	PLATE, FRICTION	6	
5	B90-16331-00	PLATE, FRICTION 2	3	
6	5VY-16325-00	PLATE, CLUTCH 2	5	(T2.0)
7	1TD-16324-00	PLATE, CLUTCH 1	1	
8	B90-16350-10	PRESSURE PLATE ASSY	1	
9	B90-16173-00	SPRING, COMPRESSION	3	
10	B90-16352-00	PLATE, PRESSURE 2	1	
11	2CR-16337-00	SCREW, SPRING	3	
12	1TD-16383-00	SPRING, CUSHION	1	
13	1TD-16384-00	PLATE, SEAT	1	
14	4B1-16325-00	PLATE, CLUTCH 2	1	UR (T2.3)
	BR9-16324-00	PLATE, CLUTCH 1	1	UR (T1.6)
	5VY-16325-00	PLATE, CLUTCH 2	1	UR (T2.0)
15	4B1-16325-00	PLATE, CLUTCH 2	1	UR (T2.3)
	BR9-16324-00	PLATE, CLUTCH 1	1	UR (T1.6)
	5VY-16325-00	PLATE, CLUTCH 2	1	UR (T2.0)
16	1TD-16178-00	ABSORBER 3	3	
17	90201-20030	WASHER, PLATE	1	
18	90208-20001	WASHER, CONICAL SPRING	1	
19	90179-20011	NUT	1	
20	93310-33277	BEARING	1	
21	4XV-16356-01	ROD, PUSH 1	1	
22	1RC-16340-00	PUSH LEVER ASSY	1	
23	90508-18051	SPRING, TORSION	1	



B901300-R161

FIG. 16 CLUTCH

REF. NO.	PART NO.	DESCRIPTION	B2/K2	REMARKS
24	90201-10029	WASHER, PLATE	1	
25	99009-10400	CIRCLIP	1	
26	5VY-16164-00	PLATE, THRUST 2	1	
27	2C0-16164-00	PLATE, THRUST 2	1	
28	1RC-16181-00	SPACER 1	1	
29	93102-15212	OIL SEAL	1	
30	93315-21570	BEARING	1	
31	5VY-16382-10	AXLE, PUSH LEVER	1	
32	93317-11096	BEARING	1	
33	92907-08600	WASHER, PLATE	1	
34	99001-07600	CIRCLIP	1	

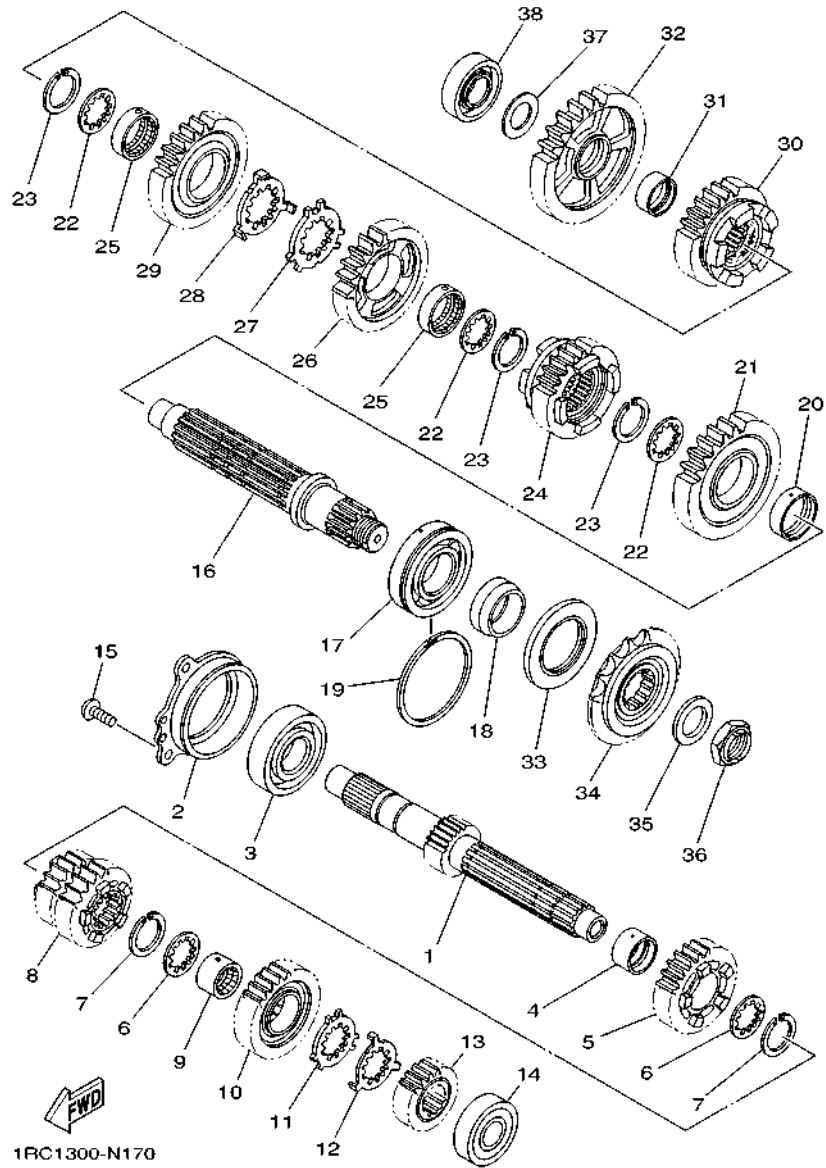


FIG. 17 TRANSMISSION

REF. NO.	PART NO.	DESCRIPTION	B2/K2	REMARKS
1	1RC-17411-00	AXLE, MAIN (15T)	1	
2	1RC-15163-00	HOUSING, BEARING 1	1	
3	93306-30534	BEARING	1	
4	90387-25030	COLLAR	1	
5	1RC-17151-00	GEAR, 5TH PINION (21T)	1	
6	90209-21332	WASHER	2	
7	93440-25186	CIRCLIP	2	
8	1RC-17131-00	GEAR, 3RD PINION (21T/21T)	1	
9	90387-21003	COLLAR	1	
10	1RC-17161-00	GEAR, 6TH PINION (27T)	1	
11	90209-22352	WASHER	1	
12	90209-21351	WASHER	1	
13	1RC-17121-00	GEAR, 2ND PINION (19T)	1	
14	93306-20464	BEARING	1	
15	90149-06082	SCREW	3	
16	1RC-17421-00	AXLE, DRIVE	1	
17	93306-20663	BEARING	1	
18	90387-30012	COLLAR	1	
19	93440-64199	CIRCLIP	1	
20	90387-31003	COLLAR	1	
21	2PP-17221-00	GEAR, 2ND WHEEL (38T)	1	
22	90209-28008	WASHER	3	
23	93440-31187	CIRCLIP	3	
24	2PP-17261-00	GEAR, 6TH WHEEL (28T)	1	
25	90387-28004	COLLAR	2	
26	1RC-17241-00	GEAR, 4TH WHEEL (29T)	1	
27	90214-29002	WASHER, CLAW	1	

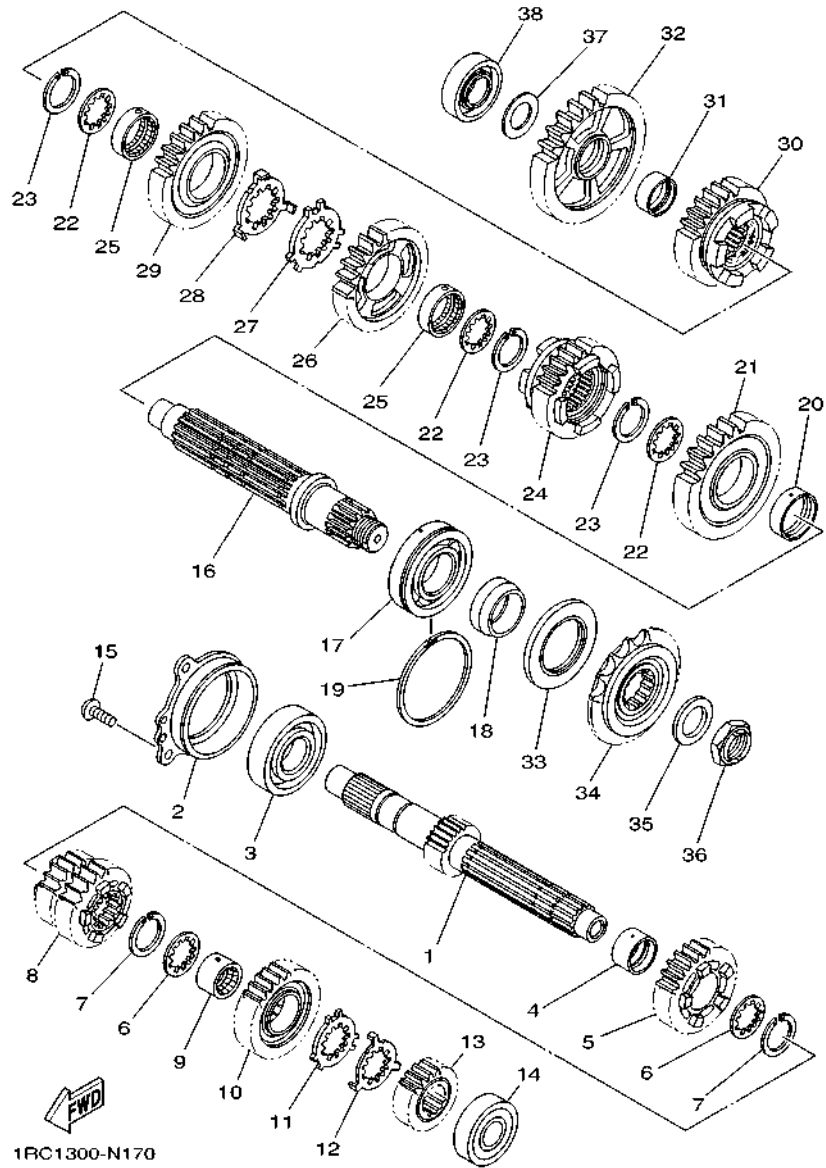
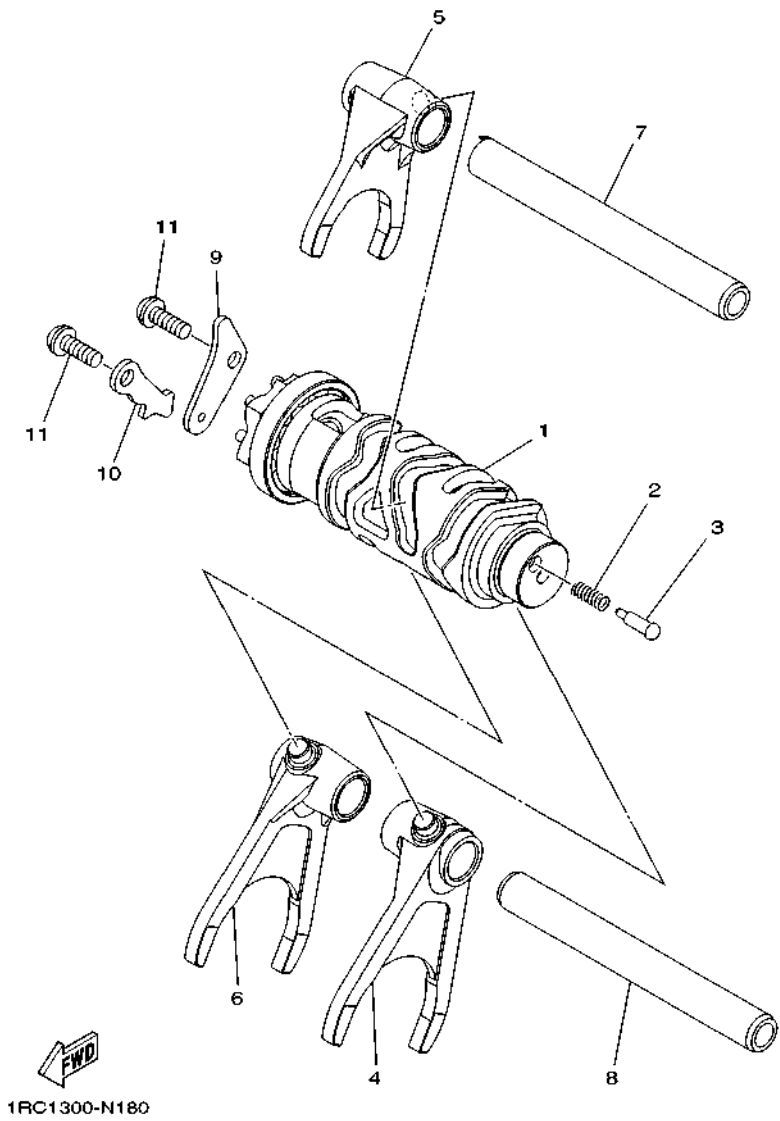


FIG. 17 TRANSMISSION

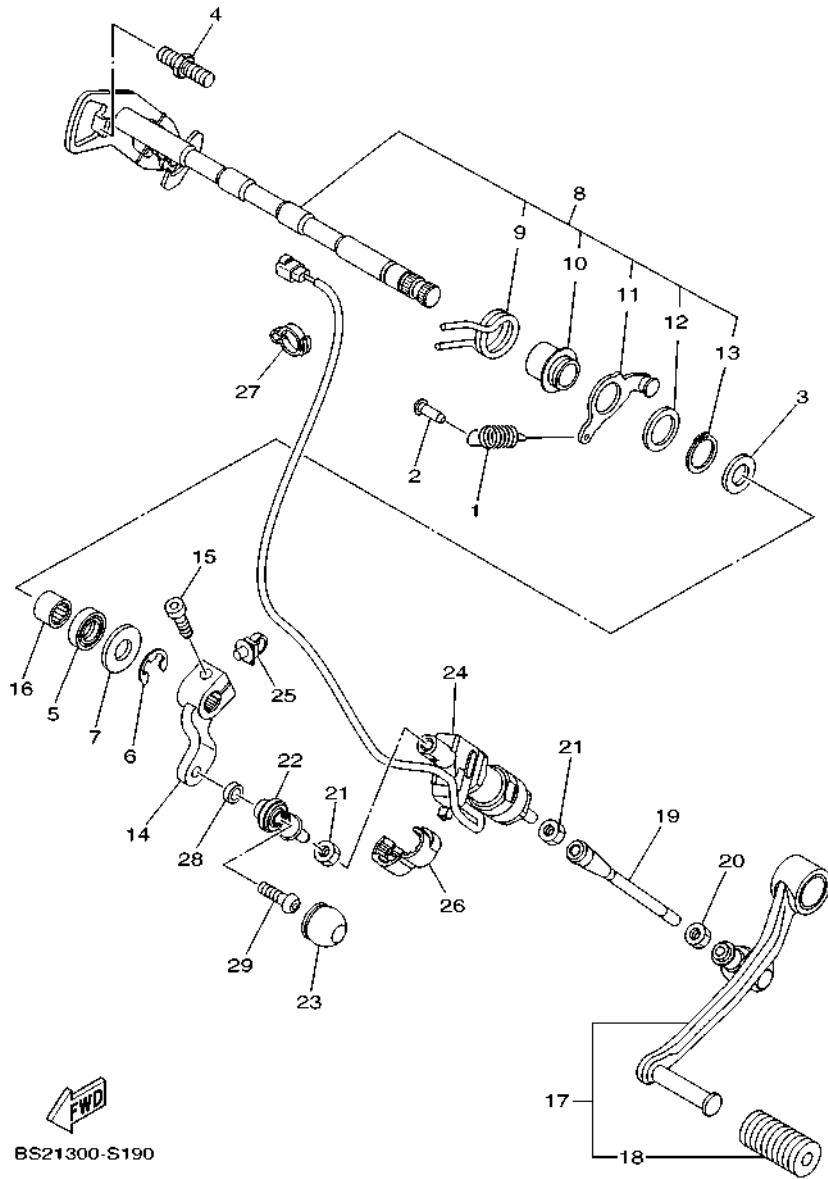
REF. NO.	PART NO.	DESCRIPTION	B2/K2				REMARKS
28	90214-28002	WASHER, CLAW	1				
29	1RC-17231-00	GEAR, 3RD WHEEL (34T)	1				
30	1RC-17251-10	GEAR, 5TH WHEEL (25T)	1				
31	90387-25008	COLLAR	1				
32	1RC-17211-00	GEAR, 1ST WHEEL (40T)	1				
33	93102-40030	OIL SEAL	1				
34	5PS-17460-00	SPROCKET, DRIVE (16T)	1				
35	90208-22002	WASHER, CONICAL SPRING	1				
36	90179-22018	NUT	1				
37	90201-20008	WASHER, PLATE	1				
38	93306-20464	BEARING	1				



**FIG. 18 SHIFT CAM & FORK**



REF. NO.	PART NO.	DESCRIPTION	B2/K2				REMARKS
1	1RC-18540-00	SHIFT CAM ASSY	1				
2	90501-06022	SPRING, COMPRESSION	1				
3	3D7-18542-00	POINT, NEUTRAL	1				
4	1RC-18511-00	FORK, SHIFT 1	1				
5	1RC-18512-00	FORK, SHIFT 2	1				
6	1RC-18513-00	FORK, SHIFT 3	1				
7	1RC-18531-00	BAR, SHIFT FORK GUIDE 1	1				
8	20S-18535-00	BAR, SHIFT FORK GUIDE 2	1				
9	2C0-18536-00	STOPPER, SHIFT BAR	1				
10	1RC-18562-00	PLATE, STOPPER 2	1				
11	90149-06158	SCREW	2				



BS21300-S190

FIG. 19 SHIFT SHAFT

REF. NO.	PART NO.	DESCRIPTION	B2/K2				REMARKS
1	90506-18021	SPRING, TENSION	1				
2	132-16346-00	HOOK, SPRING	1				
3	90201-127E1	WASHER, PLATE	1				
4	1D7-18127-00	STOPPER, SCREW	1				
5	93102-12106	OIL SEAL (SD 12-22-5 HS)	1				
6	99002-10600	CIRCLIP	1				
7	90201-12575	WASHER, PLATE	1				
8	1RC-18101-01	SHIFT SHAFT ASSY	1				
9	90508-32141	.SPRING, TORSION	1				
10	2C0-18175-00	.SPACER	1				
11	1RC-18140-00	.STOPPER LEVER ASSY	1				
12	90201-177G4	.WASHER, PLATE	1				
13	99009-17400	.CIRCLIP	1				
14	1RC-18112-00	ARM, SHIFT	1				
15	91312-06020	BOLT, HEXAGON SOCKET HEAD	1				
16	93317-11295	BEARING	1				
17	1RC-18110-00	SHIFT PEDAL ASSY	1				
18	5EB-18113-00	.COVER, SHIFT PEDAL	1				
19	BS2-18115-00	ROD, SHIFT	1				
20	90170-06228	NUT (COUNTER CLOCKWISE)	1				
21	95304-06700	NUT	2				
22	5LV-18116-00	JOINT, ROD 1	1				
23	4XV-18154-00	COVER, DUST	1				
24	BS2-82470-00	SHIFT SWITCH ASSY	1				
25	90464-30011	CLAMP	1				
26	90464-13227	CLAMP	1				
27	90464-14010	CLAMP	1				

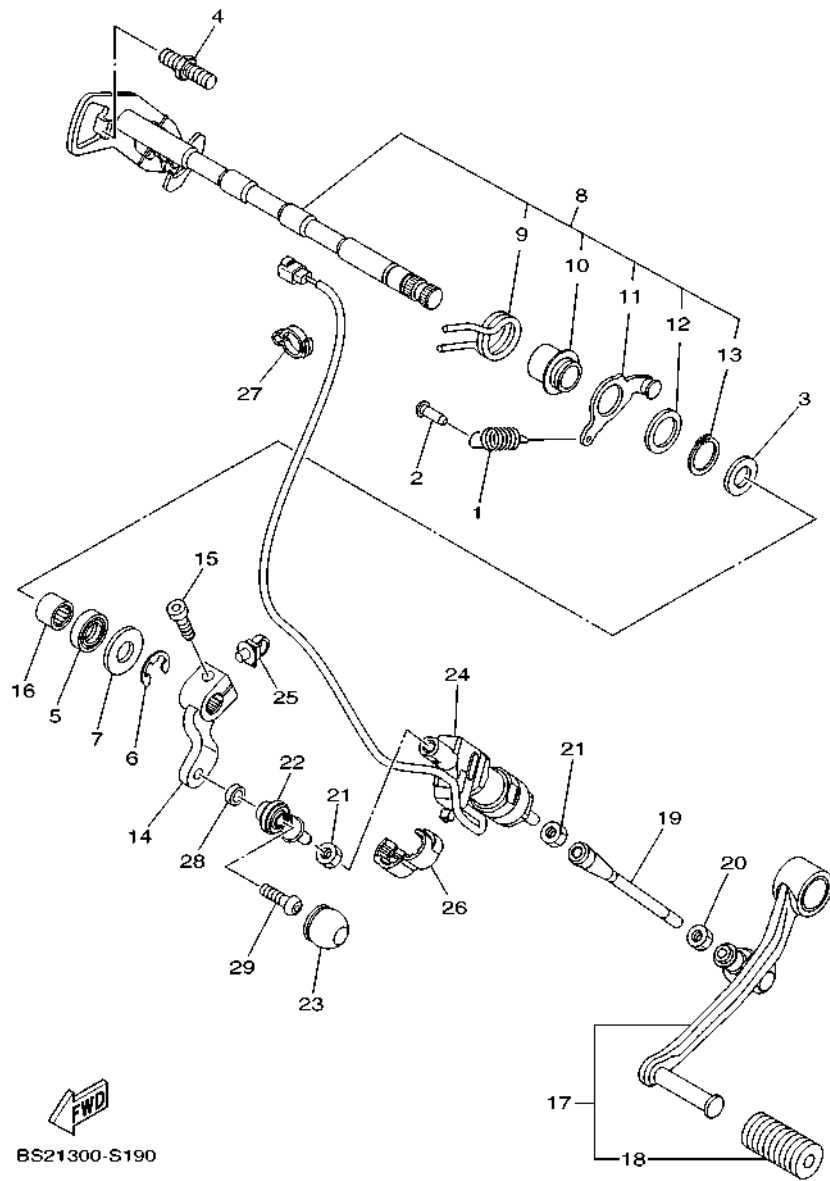
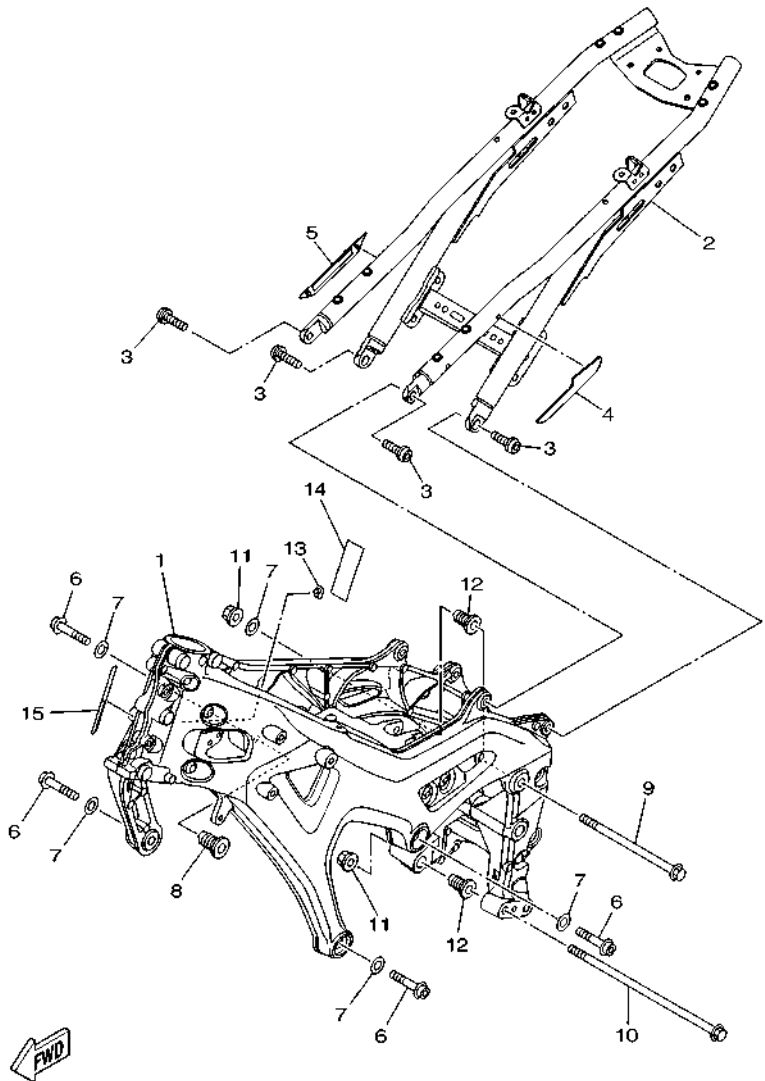


FIG. 19 SHIFT SHAFT

REF. NO.	PART NO.	DESCRIPTION	B2/K2				REMARKS
28	90387-06322	COLLAR	1				
29	92012-06020	BOLT, BUTTON HEAD	1				
-----							
-----							
-----							
-----							
-----							
-----							
-----							
-----							
-----							



BS21 300-S200

FIG. 20 FRAME

REF. NO.	PART NO.	DESCRIPTION	B2/K2				REMARKS
1	1RC-21110-80	FRAME COMP.	1				
2	BS2-21190-00	REAR FRAME COMP.	1				
3	90149-10060	SCREW	4				
4	1RC-2117X-00	COVER 9	1				
5	1RC-2117Y-00	COVER 10	1				
6	90110-10043	BOLT, HEXAGON SOCKET HEAD	4				
7	90201-10075	WASHER, PLATE	5				
8	1RC-21495-00	BOLT, ENGINE ADJUSTING	1				
9	90105-10391	BOLT, FLANGE	1				
10	90105-10437	BOLT, FLANGE	1				
11	90179-10024	NUT	2				
12	4C8-21495-00	BOLT, ENGINE ADJUSTING	2				
13	5VX-21289-00	PLUG, BLIND	1				
14	34D-82176-00	DAMPER	1				
15	1RC-2117G-00	PROTECTOR	1				

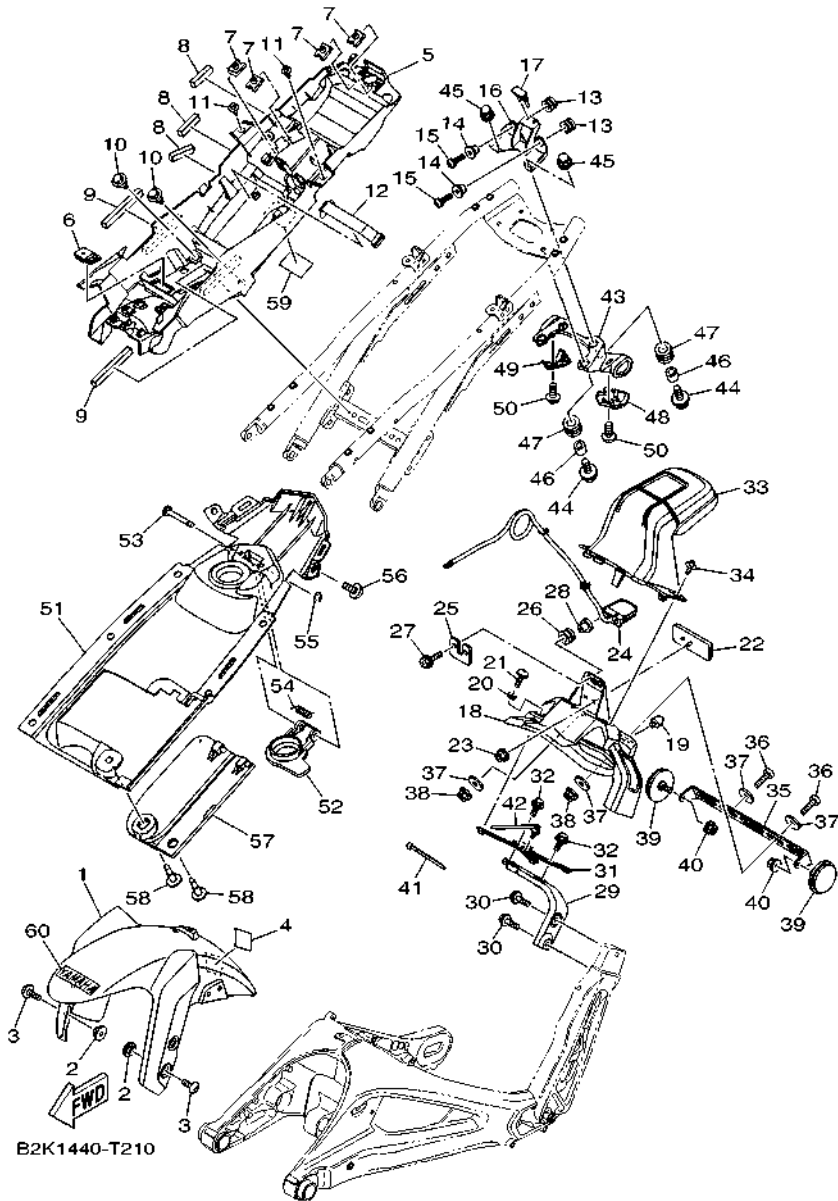
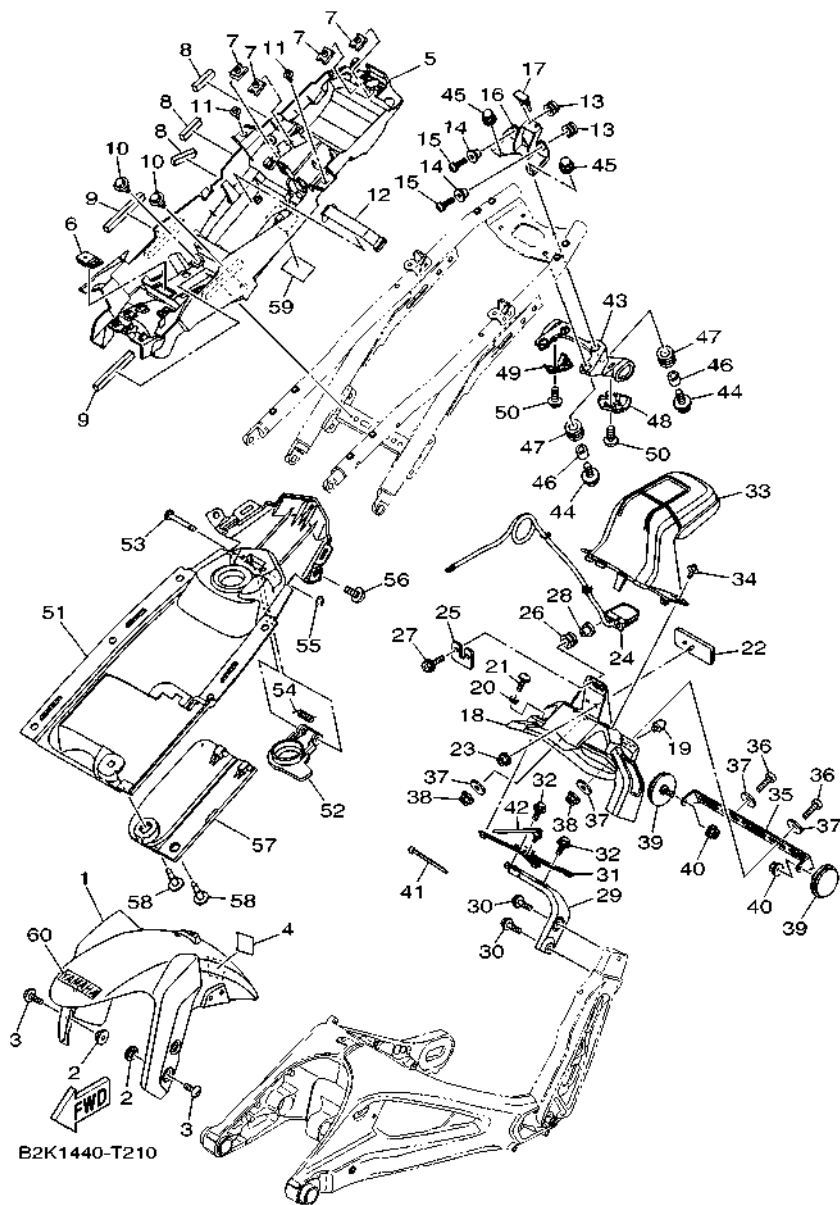


FIG. 21 FENDER

REF. NO.	PART NO.	DESCRIPTION	B2K2			REMARKS
1	1RC-21511-00-33	FENDER, FRONT	1			UR YB FOR DPBMC
	1RC-21511-00-PF	FENDER, FRONT	1			UR FOR MLNM4
2	90387-06153	COLLAR	4			
3	90110-06200	BOLT, HEXAGON SOCKET HEAD	4			
4	5UY-21269-00	SEAL	1			
5	BS2-8212B-00	BOX, BATTERY 1	1			
6	2DR-26199-00	PLUG, BLIND	1			
7	90183-06069	NUT, SPRING	4			
8	5PS-28372-00	DAMPER	3			
9	32D-84553-00	DAMPER	2			
10	90109-06202	BOLT	2			
11	90269-07007	RIVET	2			
12	1RC-82137-00	BAND, BATTERY	1			
13	90480-14052	GROMMET	2			
14	90387-06288	COLLAR	2			
15	92012-06020	BOLT, BUTTON HEAD	2			
16	BS2-2117E-00	BRACKET, TAILLIGHT	1			
17	682-44532-00	STOPPER, UPPER MOUNT	1			
18	BS2-21629-01	GUARD, MUD	1			
19	2MG-21639-00	DAMPER 2	1			
20	90387-06372	COLLAR	4			
21	90111-06061	BOLT, HEX. SOCKET BUTTON	4			
22	3Y6-85130-02	REAR REFLECTOR ASSY	1			
23	95602-05200	NUT, SELF-LOCKING	1			
24	BS2-84745-00	LICENCE LIGHT UNIT ASSY	1			
25	BS2-21681-00	PLATE, LICENSE	1			
26	90480-11009	GROMMET	2			

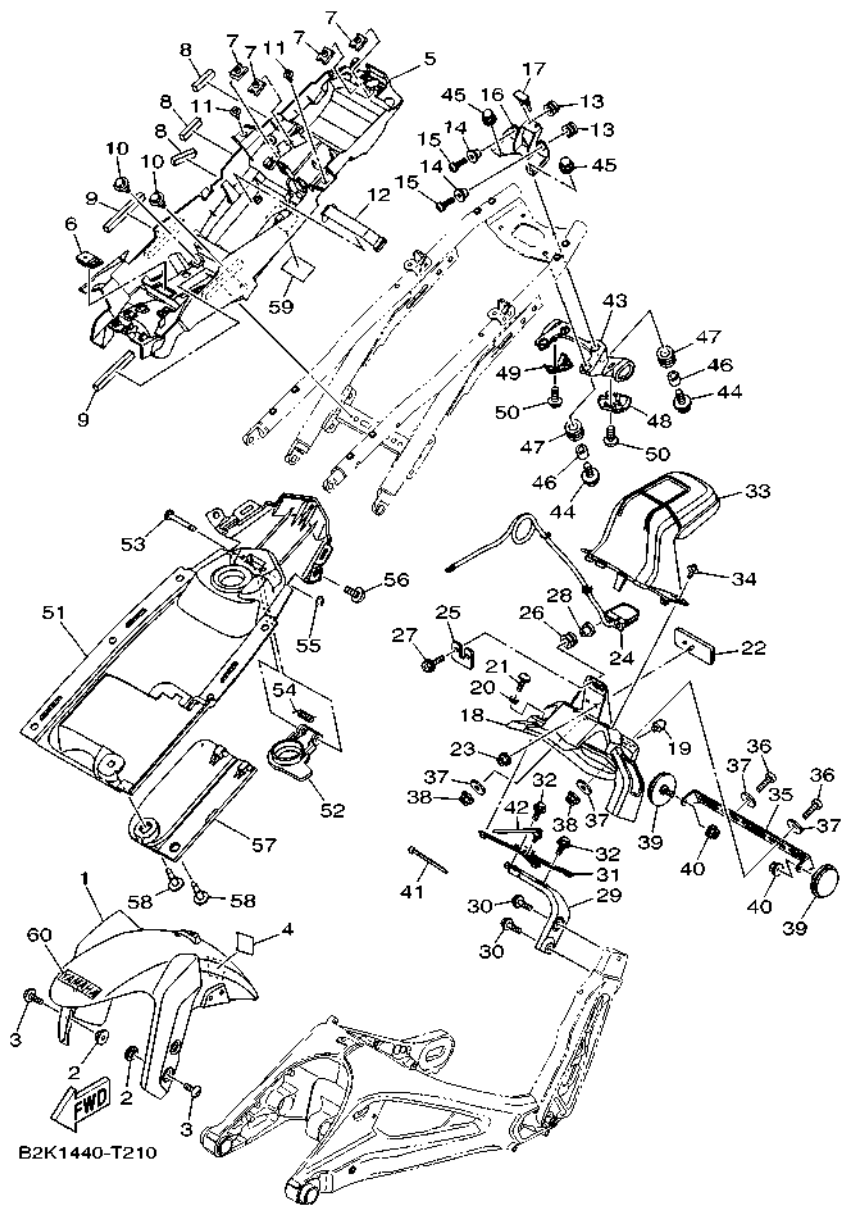
FIG. 21 FENDER



B2K1440-T210

REF. NO.	PART NO.	DESCRIPTION	B2K2			REMARKS
27	90159-05035	SCREW, WITH WASHER	2			
28	90387-05003	COLLAR	2			
29	BS2-21613-00	STAY, FENDER 1	1			
30	95817-08025	BOLT, FLANGE	2			
31	BS2-21614-00	STAY, FENDER 2	1			
32	95812-06014	BOLT, FLANGE	3			
33	BS2-2163A-00	COVER, REAR FENDER 1	1			
34	90269-06008	RIVET	2			
35	BS2-84751-00	BRACKET, LICENSE	1			
36	98507-06020	SCREW, PAN HEAD	2			
37	90201-06557	WASHER, PLATE	4			
38	95602-06200	NUT, SELF-LOCKING	2			
39	4AG-85111-00	REFLECTOR, FRONT 1	2			
40	95702-06500	NUT, FLANGE	2			
41	90464-16061	CLAMP	1			
42	90464-30011	CLAMP	1			
43	BS2-83318-00	STAY, FLASHER 1	1			
44	90105-06169	BOLT, FLANGE	4			
45	90176-06016	NUT, CAP	4			
46	90387-06260	COLLAR	4			
47	90480-14003	GROMMET	4			
48	BS2-283D3-00	COVER, FLASHER 1	1			
49	BS2-283D4-00	COVER, FLASHER 2	1			
50	97707-40012	SCREW, TAPPING	2			
51	BS2-21651-00	COVER, REAR FENDER	1			
52	1RC-2465B-00	CAP, ROTOR	1			
53	90249-03002	PIN	1			

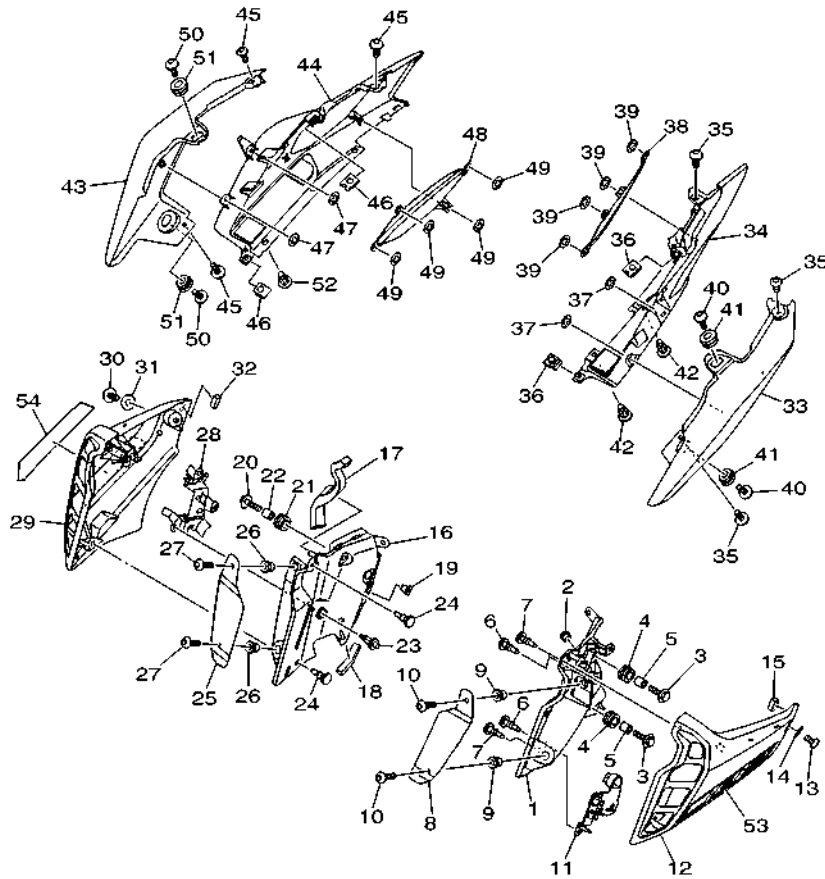
FIG. 21 FENDER



B2K1440-T210

REF. NO.	PART NO.	DESCRIPTION	B2K2	REMARKS
54	90508-09007	SPRING, TORSION	1	
55	93430-02001	CIRCLIP	1	
56	90167-05079	SCREW, TAPPING	2	
57	BS2-2177E-00	LID	1	
58	90269-07007	RIVET	2	
59	BM6-21668-00	LABEL, TIRE	1	
60	99247-00080	EMBLEM, YAMAHA	1	UR FOR DPBMC
	99244-00080	EMBLEM, YAMAHA	1	UR FOR MLNM4

**FIG. 22 SIDE COVER**

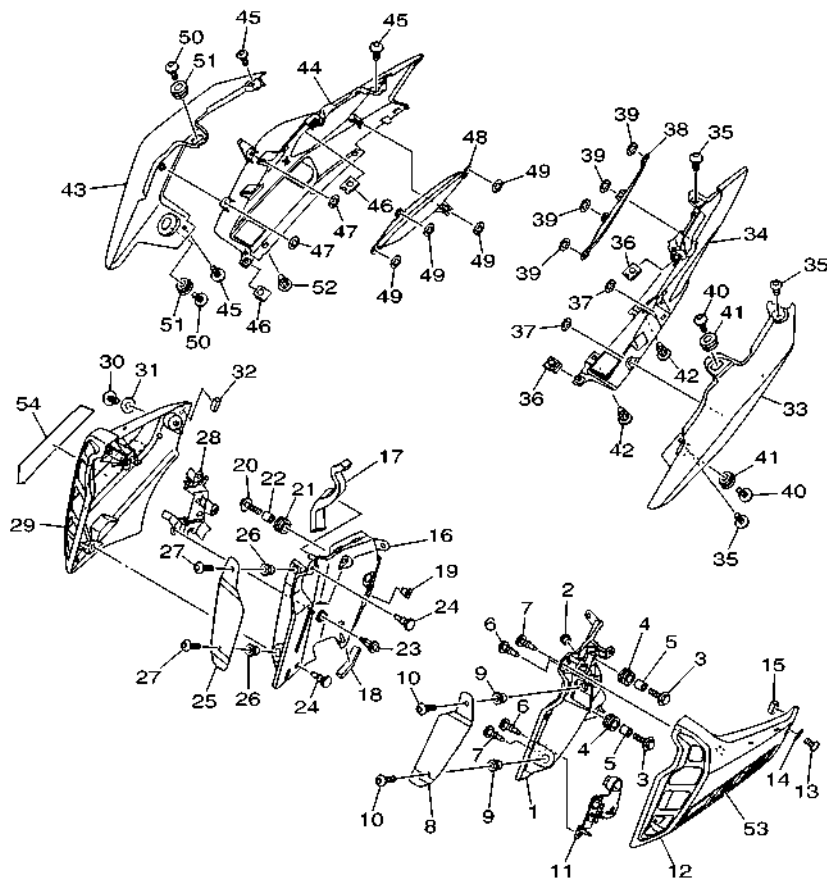


  
BS2B370-T220

REF. NO.	PART NO.	DESCRIPTION	B2/K2	REMARKS
1	BS2-2172E-00	STAY, SIDE COVER 1	1	
2	90338-06018	PLUG	1	
3	90119-06267	BOLT, WITH WASHER	2	
4	90480-14003	GROMMET	2	
5	90387-06057	COLLAR	2	
6	90269-06008	RIVET	2	
7	90269-06001	RIVET	2	
8	BS2-2837N-00	GRILL, AIR INTAKE 1	1	
9	90179-06520	NUT	2	
10	90111-06146	BOLT,HEX. SOCKET BUTTON	2	
11	BS2-8336T-00	HOLDER 1	1	
12	BS2-2137W-00-P0	SCOOP, AIR 1	1	MBL2
13	90111-05002	BOLT,HEX. SOCKET BUTTON	1	
14	90202-05180	WASHER, PLATE	1	
15	1RC-21747-00	DAMPER	1	
16	BS2-2174E-00	STAY, SIDE COVER 2	1	
17	90520-10022	DAMPER, PLATE	1	
18	90520-10003	DAMPER, PLATE	1	
19	90338-06018	PLUG	1	
20	90119-06267	BOLT, WITH WASHER	2	
21	90480-14003	GROMMET	2	
22	90387-06057	COLLAR	2	
23	90269-06008	RIVET	3	
24	90269-06001	RIVET	2	
25	BS2-2837R-00	GRILL, AIR INTAKE 2	1	
26	90179-06520	NUT	2	
27	90111-06146	BOLT,HEX. SOCKET BUTTON	2	



**FIG. 22 SIDE COVER**

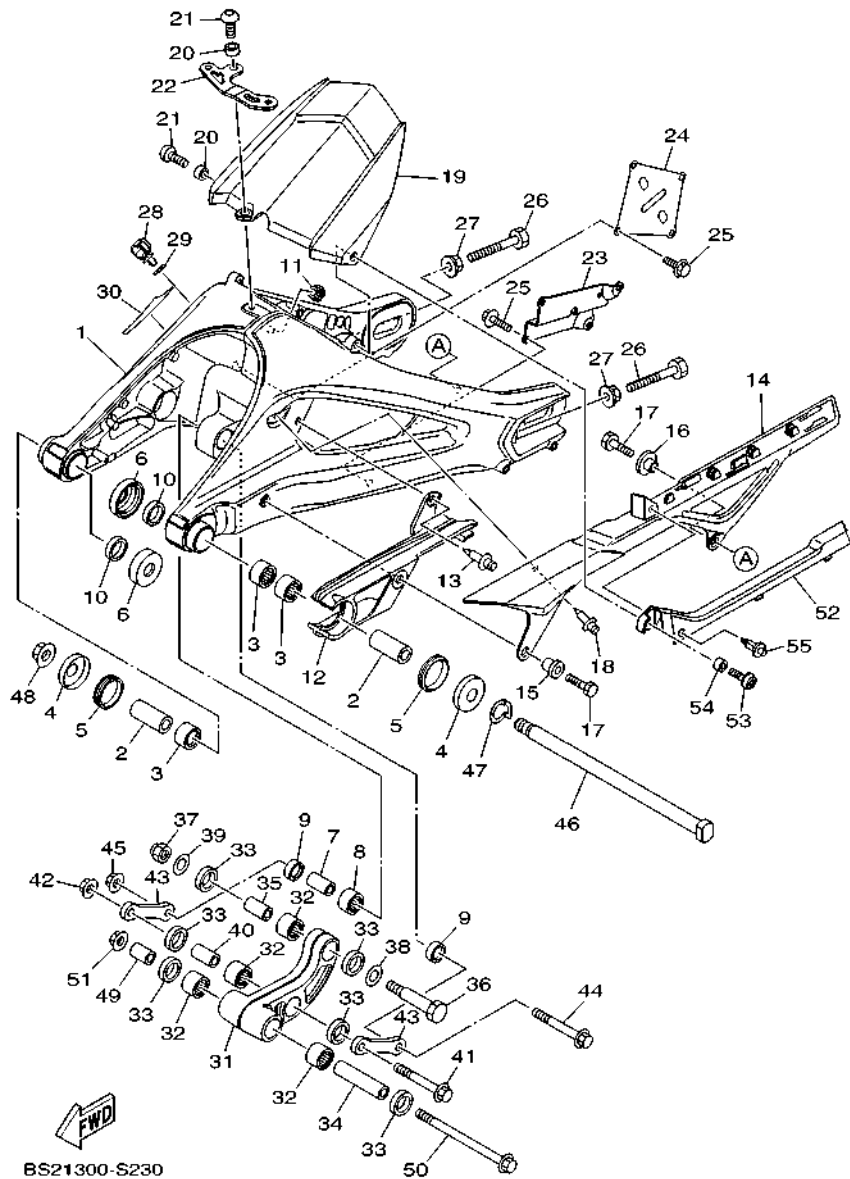


**FWD**  
BS2B370-T220

REF. NO.	PART NO.	DESCRIPTION	B2/K2	REMARKS
28	BS2-8336U-00	HOLDER	1	
29	BS2-2137X-00-P0	SCOOP, AIR 2	1	MBL2
30	90111-05002	BOLT,HEX. SOCKET BUTTON	1	
31	90202-05180	WASHER, PLATE	1	
32	1RC-21747-00	DAMPER	1	
33	BS2-21711-00-33	COVER, SIDE 1	1	UR YB FOR DPBMC
	BS2-21711-00-P7	COVER, SIDE 1	1	UR FOR MLNM4
34	BS2-21731-00	COVER, SIDE 3	1	
35	90111-05002	BOLT,HEX. SOCKET BUTTON	3	
36	90183-05076	NUT, SPRING	2	
37	90183-05M02	NUT, SPRING	2	
38	BS2-2171Y-00	GRILLE, SIDE COVER 1	1	
39	90183-05M02	NUT, SPRING	4	
40	90109-06037	BOLT	2	
41	90480-01559	GROMMET	2	
42	90269-07007	RIVET	3	
43	BS2-21721-00-33	COVER, SIDE 2	1	UR YB FOR DPBMC
	BS2-21721-00-P7	COVER, SIDE 2	1	UR FOR MLNM4
44	BS2-21741-00	COVER, SIDE 4	1	
45	90111-05002	BOLT,HEX. SOCKET BUTTON	3	
46	90183-05076	NUT, SPRING	2	
47	90183-05M02	NUT, SPRING	2	
48	BS2-2172Y-00	GRILLE, SIDE COVER 2	1	
49	90183-05M02	NUT, SPRING	4	
50	90109-06037	BOLT	2	
51	90480-01559	GROMMET	2	
52	90269-07007	RIVET	2	

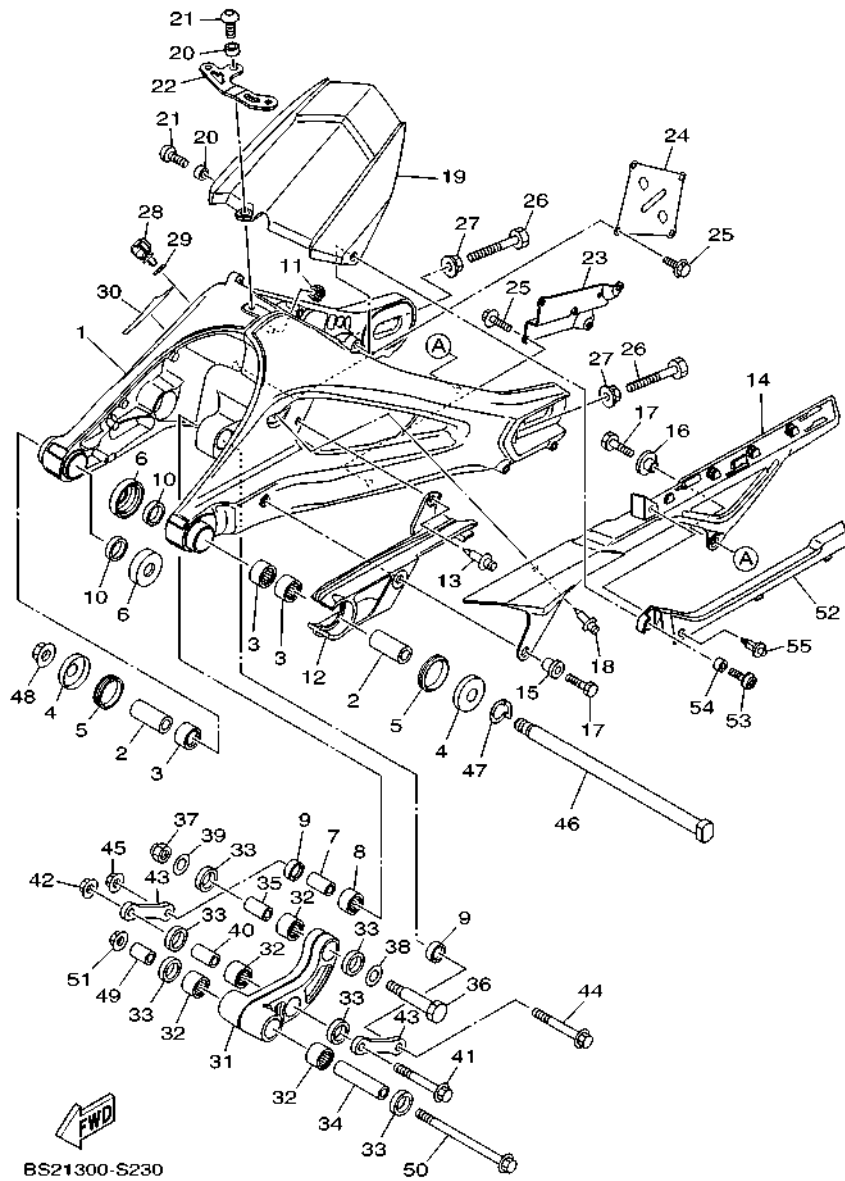


FIG. 23 REAR ARM



BS21300-S230

REF. NO.	PART NO.	DESCRIPTION	B2K2				REMARKS
1	B90-22110-01	REAR ARM COMP.	1				
2	90380-16134	BUSH, SOLID	2				
3	93317-22262	BEARING	3				
4	30X-2219X-00	COVER	2				
5	93108-35004	OIL SEAL (35-41-8)	2				
6	20S-22128-00	COVER, THRUST 1	2				
7	90387-102R4	COLLAR	1				
8	93315-31758	BEARING	1				
9	93109-17071	OIL SEAL	2				
10	93106-22002	OIL SEAL	2				
11	90480-12012	GROMMET	1				
12	1RC-22151-00	SEAL, GUARD	1				
13	90269-07007	RIVET	1				
14	BS2-22311-00	CASE, CHAIN	1				
15	90387-062X0	COLLAR	1				
16	90387-06066	COLLAR	1				
17	97002-06016	BOLT, HEXAGON	2				
18	90269-07007	RIVET	1				
19	1RC-21650-00	REAR FENDER COMP.	1				
20	90387-06022	COLLAR	2				
21	90111-06161	BOLT,HEX. SOCKET BUTTON	2				
22	BS2-27425-00	BRACKET, FOOTREST 2	1				
23	1RC-2221A-00	BRACKET 1	1				
24	1RC-2221B-00	BRACKET 2	1				
25	90105-06126	BOLT, FLANGE	8				
26	90101-08013	BOLT	2				
27	95702-08500	NUT, FLANGE	2				

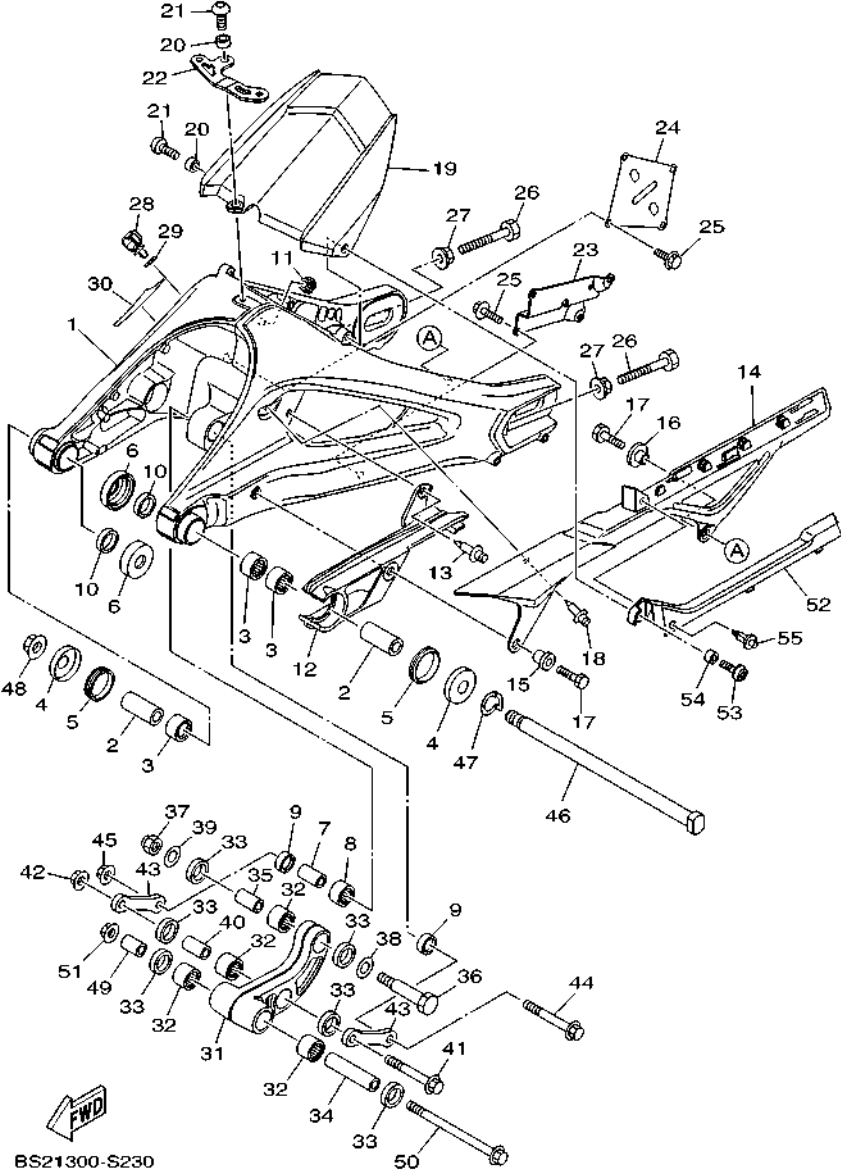


BS21300-S230

FIG. 23 REAR ARM

REF. NO.	PART NO.	DESCRIPTION	B2K2				REMARKS
28	90464-18002	CLAMP	1				
29	90202-07164	WASHER, PLATE	1				
30	1RC-22358-00	SEAL 1	1				
31	1RC-2217A-00	ARM, RELAY	1				
32	93315-31758	BEARING	4				
33	93109-17071	OIL SEAL	6				
34	3GB-23448-00	SPACER	1				
35	90387-127W0	COLLAR	1				
36	90109-10027	BOLT	1				
37	95612-10100	NUT, U	1				
38	90201-13015	WASHER, PLATE	1				
39	90201-10035	WASHER, PLATE	1				
40	90387-102R4	COLLAR	1				
41	90105-10210	BOLT, FLANGE	1				
42	95602-10200	NUT, S/L FLANGE	1				
43	1RC-2217M-00	ARM 1	2				
44	90105-10210	BOLT, FLANGE	1				
45	95602-10200	NUT, S/L FLANGE	1				
46	46X-22141-00	SHAFT, PIVOT	1				
47	1RC-22159-00	WASHER, SPRING LOWER	1				
48	95602-14200	NUT, SELF-LOCKING	1				
49	90387-10106	COLLAR	1				
50	90105-10174	BOLT, FLANGE	1				
51	95602-10200	NUT, S/L FLANGE	1				
52	BS2-2219X-00	COVER	1				
53	90149-06104	SCREW	1				
54	90387-06207	COLLAR	1				

FIG. 23 REAR ARM



BS21300-S230

REF. NO.	PART NO.	DESCRIPTION	B2/K2					REMARKS
55	90269-07007	RIVET	1					



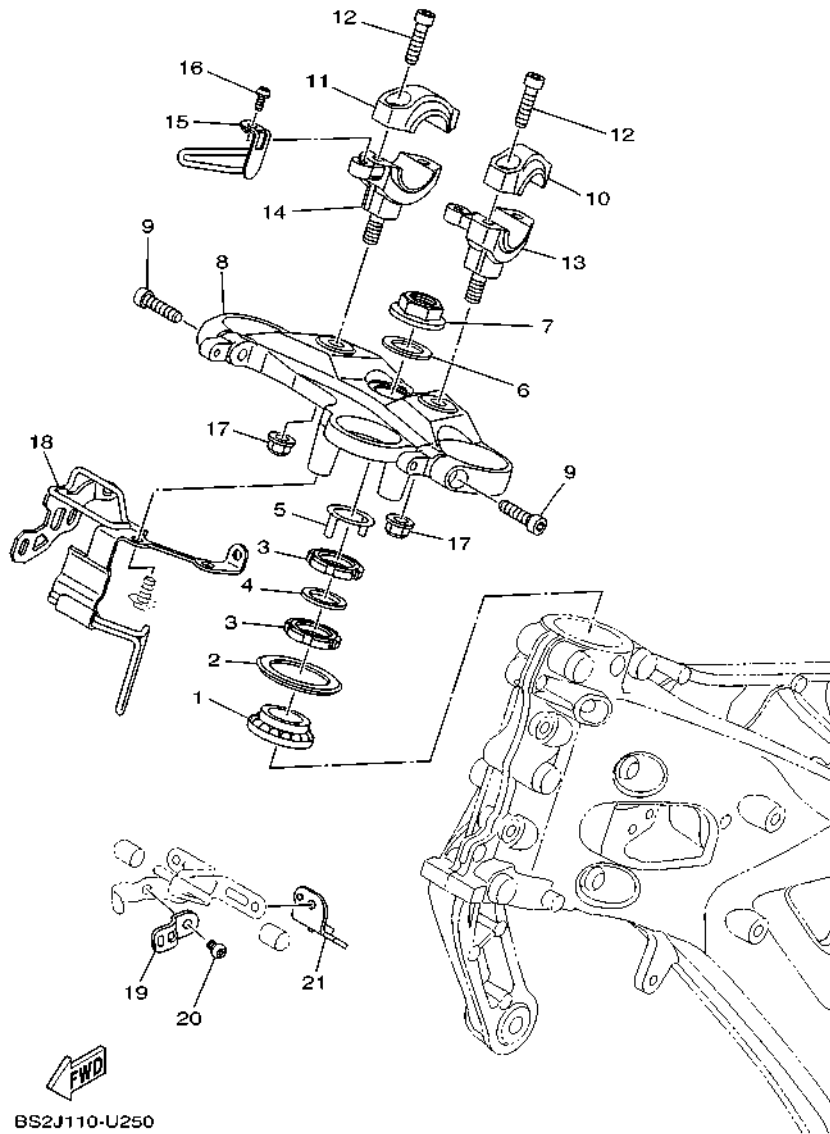


FIG. 25 STEERING

REF. NO.	PART NO.	DESCRIPTION	B2K2				REMARKS
1	93399-99931	BEARING	1				
2	5VX-23415-00	COVER, BALL RACE 1	1				
3	90179-25004	NUT	2				
4	90202-26142	WASHER, PLATE	1				
5	26H-23418-01	WASHER, SPECIAL	1				
6	90201-22018	WASHER, PLATE	1				
7	1RC-23393-00	NUT, SPECIAL	1				
8	1RC-23435-30	CROWN, HANDLE	1				
9	91314-08030	BOLT, HEXAGON SOCKET HEAD	2				
10	1RC-23441-11	HOLDER, HANDLE UPPER	1				
11	1RC-2344A-11	HOLDER, HANDLE UPPER 1	1				
12	91314-08030	BOLT, HEXAGON SOCKET HEAD	4				
13	1RC-24847-12	HOLDER 1	1				
14	1RC-24848-12	HOLDER 2	1				
15	BS2-23591-00	BRACKET 1	1				
16	90149-06298	SCREW	2				
17	95602-10200	NUT, S/L FLANGE	2				
18	BS2-23389-20	GUIDE, CABLE	1				
19	5SL-25876-00	HOLDER, BRAKE HOSE 2	1				
20	92017-06012	BOLT, BUTTON HEAD	1				
21	1RC-23377-00	BRACKET, HORN	1				

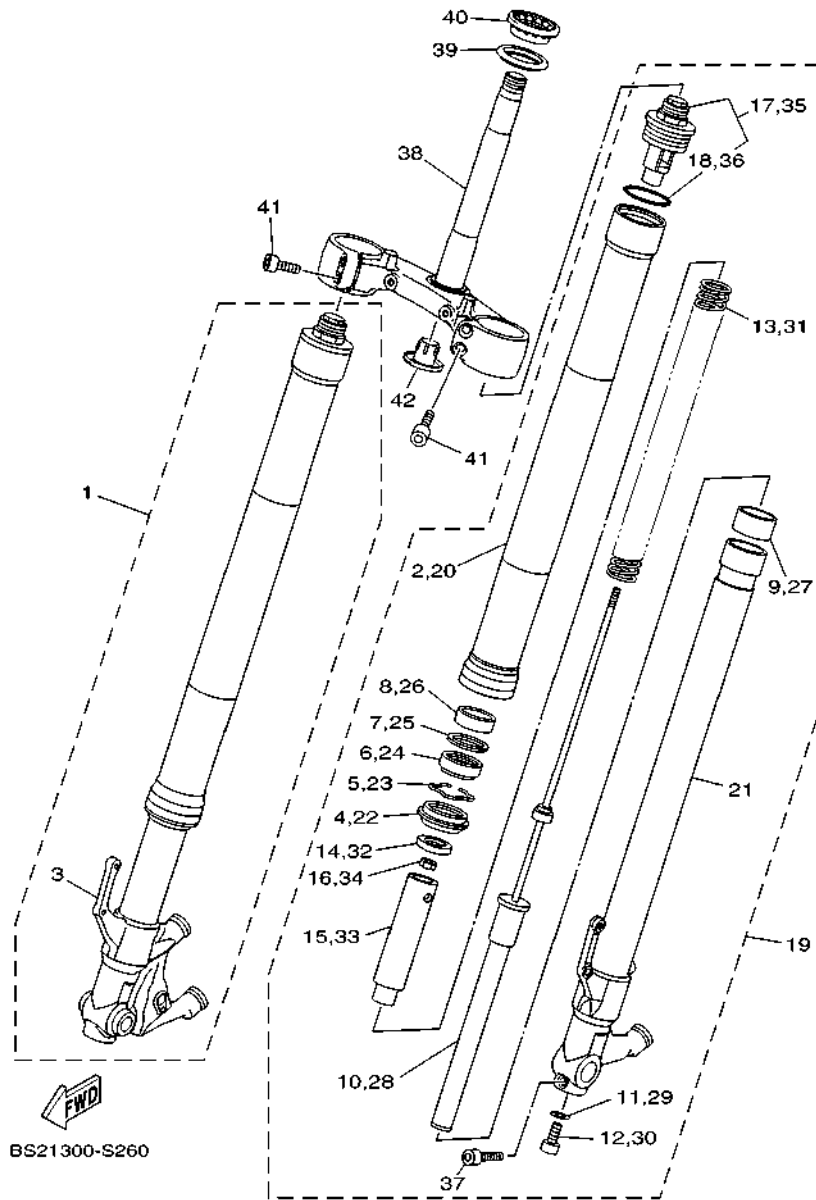


FIG. 26 FRONT FORK

REF. NO.	PART NO.	DESCRIPTION	B2K2	REMARKS
1	BS2-23103-00	FRONT FORK ASSY (R.H)	1	
2	1RC-23126-40	.TUBE, OUTER (L.H)	1	
3	BS2-23120-00	.INNER TUBE COMP.2	1	
4	4EB-23144-00	.SEAL, DUST	1	
5	26H-23156-00	.RING, SNAP	1	
6	4EB-23145-01	.OIL SEAL	1	
7	36Y-23146-10	.WASHER, OIL SEAL	1	
8	1RC-23125-00	.METAL, SLIDE 1	1	
9	4FM-23171-40	.METAL, SLIDE	1	
10	BS2-23170-10	.CYLINDER COMP., FRONT FORK	1	
11	509-23158-L0	.GASKET	1	(KYB)
12	278-23181-50	.BOLT, HEXAGON SOCKET HEAD	1	
13	1RC-23141-00	.SPRING, FRONT FORK	1	
14	5VY-12277-00	.WASHER	1	
15	1RC-23118-00	.SPACER	1	
16	3LC-23357-00	.NUT	1	
17	BS2-23111-10	.BOLT, CAP	1	
18	3XJ-23147-L0	.O-RING	1	
19	BS2-23102-00	FRONT FORK ASSY (L.H)	1	
20	1RC-23126-40	.TUBE, OUTER (L.H)	1	
21	BS2-23110-00	.INNER TUBE COMP.1	1	
22	4EB-23144-00	.SEAL, DUST	1	
23	26H-23156-00	.RING, SNAP	1	
24	4EB-23145-01	.OIL SEAL	1	
25	36Y-23146-10	.WASHER, OIL SEAL	1	
26	1RC-23125-00	.METAL, SLIDE 1	1	
27	4FM-23171-40	.METAL, SLIDE	1	



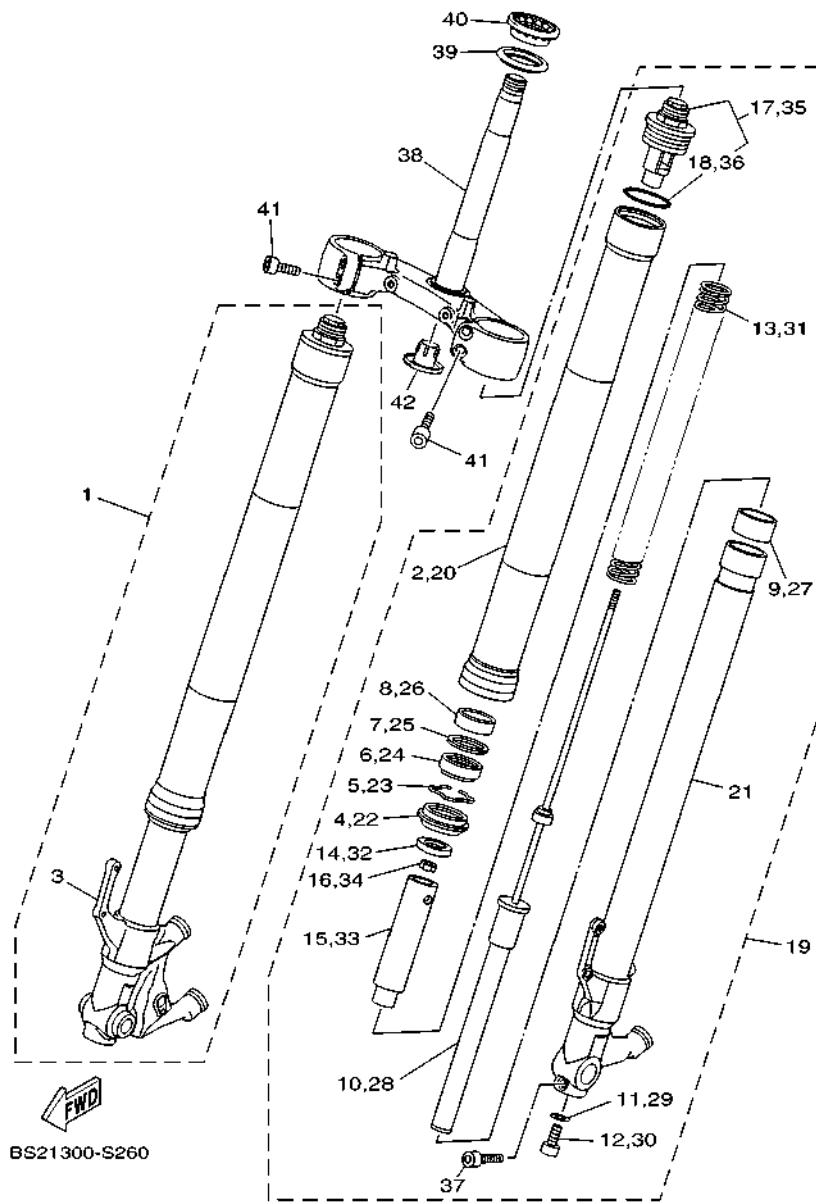
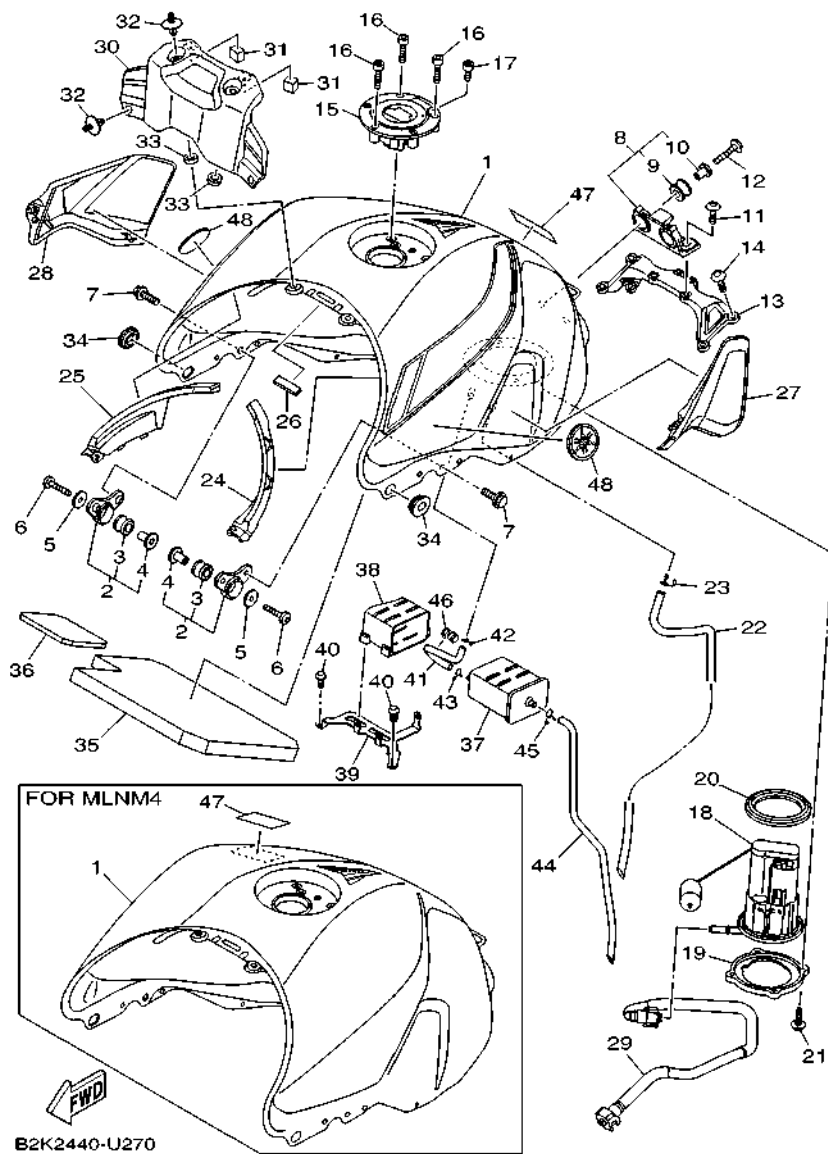


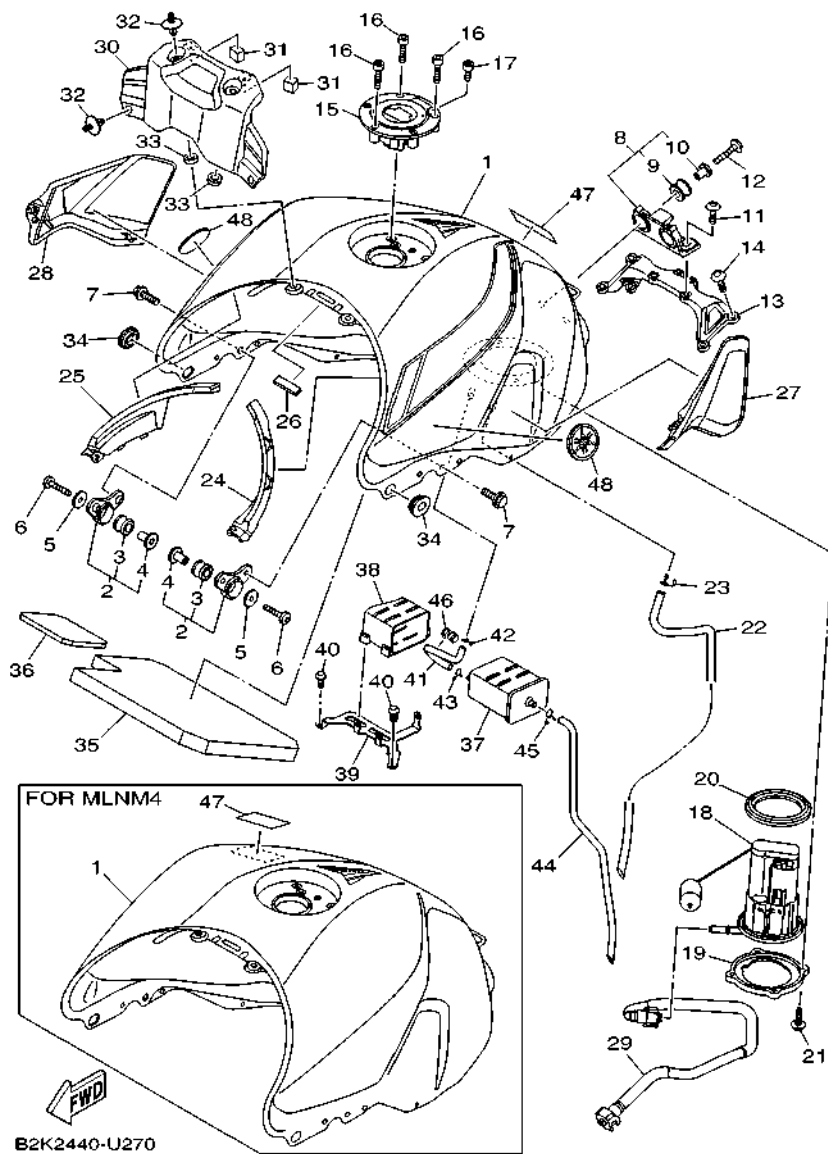
FIG. 26 FRONT FORK

REF. NO.	PART NO.	DESCRIPTION	B2K2	REMARKS
28	BS2-23170-00	.CYLINDER COMP., FRONT FORK	1	
29	509-23158-L0	.GASKET	1	(KYB)
30	278-23181-50	.BOLT, HEXAGON SOCKET HEAD	1	
31	1RC-23141-00	.SPRING, FRONT FORK	1	
32	5VY-12277-00	.WASHER	1	
33	1RC-23118-00	.SPACER	1	
34	3LC-23357-00	.NUT	1	
35	BS2-23111-00	.BOLT, CAP	1	
36	3XJ-23147-L0	..O-RING	1	
37	91314-08035	.BOLT, HEXAGON SOCKET HEAD	1	
38	1RC-23340-11	UNDER BRACKET COMP.	1	
39	3FV-23462-00	SEAL, STEERING	1	
40	93399-99932	BEARING	1	
41	91314-08030	BOLT, HEXAGON SOCKET HEAD	4	
42	4KM-23123-01	COVER, UNDER 1	1	



**FIG. 27 FUEL TANK**

REF. NO.	PART NO.	DESCRIPTION	B2K2	REMARKS
1	1RC-Y2410-00-X4	FUEL TANK COMP.	1	UR FOR DPBMC
	1RC-Y2410-00-X7	FUEL TANK COMP.	1	UR FOR MLNM4
2	23P-24104-01	TANK BRACKET ASSY	2	
3	90480-18008	.GROMMET	1	
4	90387-06266	.COLLAR	1	
5	90201-06072	WASHER, PLATE	2	
6	92012-06035	BOLT, BUTTON HEAD	2	
7	90119-06051	BOLT, WITH WASHER	4	
8	1RC-24104-00	TANK BRACKET ASSY	1	
9	3D7-24339-00	.GROMMET	2	
10	90387-06136	.COLLAR	2	
11	90111-06136	BOLT,HEX. SOCKET BUTTON	2	
12	95D32-06025	BOLT, FLANGE DEEP RECESS	2	
13	1RC-2413Y-00	BRACKET, TANK FITTING	1	
14	92017-06020	BOLT, BUTTON HEAD	4	
15	39P-24602-10	CAP ASSY	1	
16	90110-05112	BOLT, HEXAGON SOCKET HEAD	3	
17	91312-05010	BOLT, HEXAGON SOCKET HEAD	1	
18	1RC-13907-00	FUEL PUMP COMP.	1	
19	1RC-24491-00	BRACKET, FUEL PUMP	1	
20	1RC-24486-00	O-RING	1	
21	90110-05028	BOLT, HEXAGON SOCKET HEAD	4	
22	1RC-24315-00	PIPE 5	1	
23	90467-09006	CLIP	1	
24	1RC-2418B-01	MOLE, FUEL TANK 1	1	
25	1RC-2419B-01	MOLE, FUEL TANK 2	1	
26	2S3-28347-00	MOLE 3	1	



**FIG. 27 FUEL TANK**

REF. NO.	PART NO.	DESCRIPTION	B2K2				REMARKS
27	1RC-24106-01	TANK SIDE COVER ASSY 1	1				
28	1RC-24108-01	TANK SIDE COVER ASSY 2	1				
29	1RC-13971-10	PIPE, FUEL 1	1				
30	1RC-241B1-00	COVER, TANK	1				
31	90520-15012	DAMPER, PLATE	2				
32	90269-07077	RIVET	4				
33	5SL-84753-00	DAMPER	2				
34	90480-01558	GROMMET	2				
35	2PP-2414J-00	DAMPER, PLATE 2	1				
36	BS2-24141-00	PROTECTOR, FUEL TANK	1				
37	2CR-24170-00	CANISTER ASSY	1				
38	B90-24183-00	DAMPER, LOCATING 3	1				
39	B90-2419F-00	BRACKET, CANISTOR	1				
40	92012-06012	BOLT, BUTTON HEAD	2				
41	B90-24313-00	PIPE 3	1				
42	90467-09006	CLIP	1				
43	90467-09026	CLIP	1				
44	BS2-24321-00	PIPE 10	1				
45	90467-10041	CLIP	1				
46	90464-09M31	CLAMP	1				
47	4C8-21568-10	LABEL, WARNING	1				
48	1RC-2413B-01	EMBLEM	2				

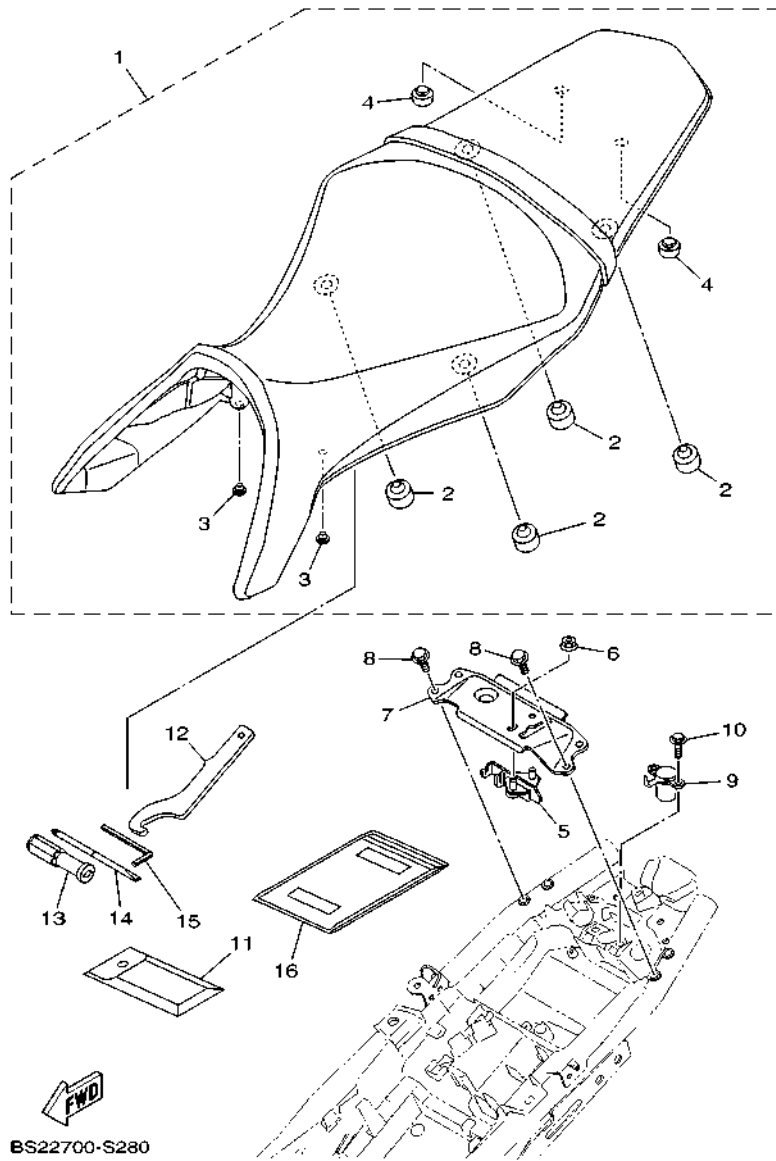
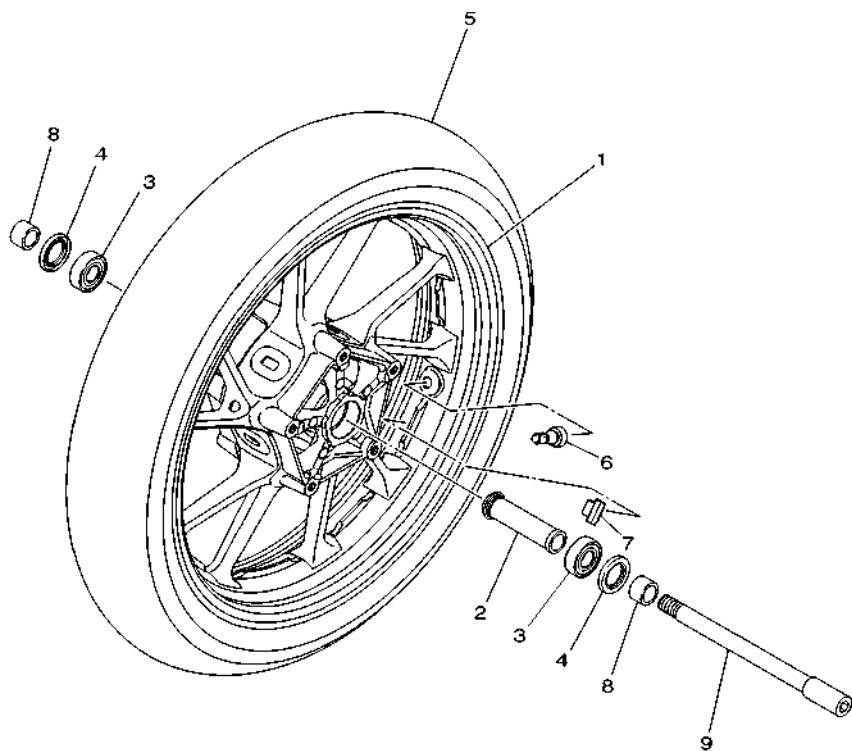


FIG. 28 SEAT

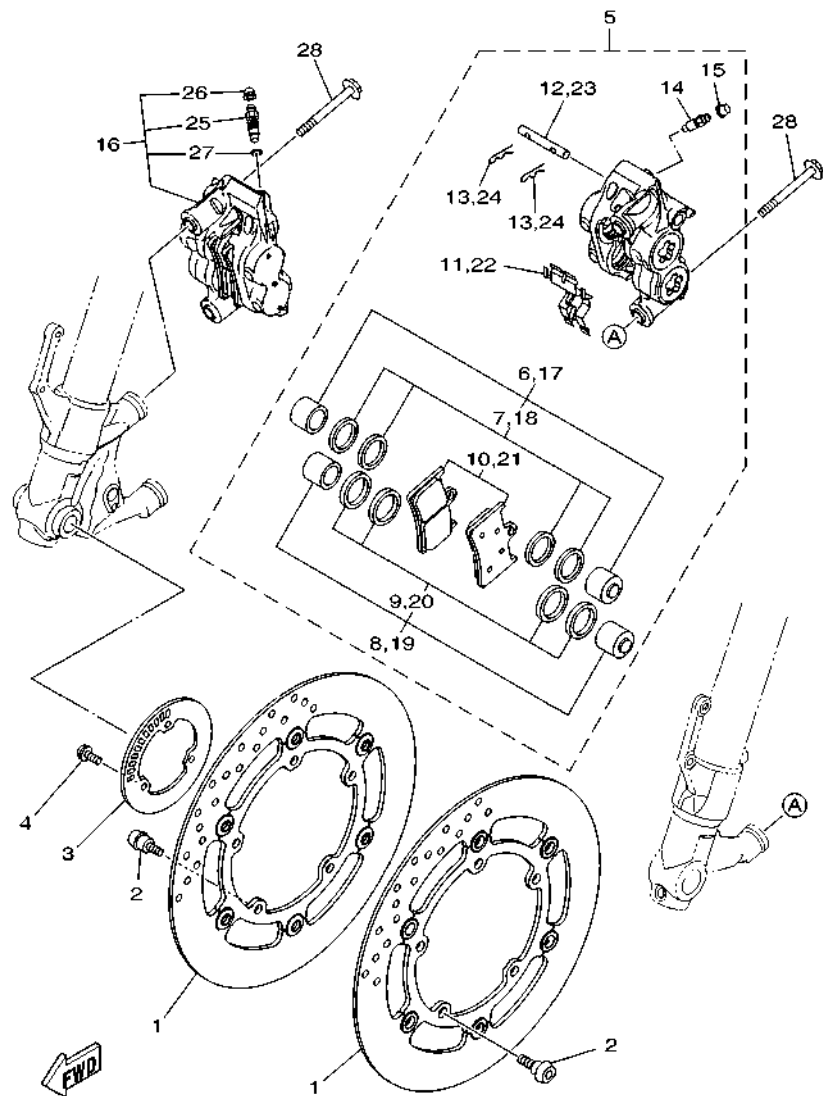
REF. NO.	PART NO.	DESCRIPTION	B2/K2				REMARKS
1	BS2-24730-00	DOUBLE SEAT ASSY	1				
2	4GL-27114-00	.STOPPER, MAIN STAND	4				
3	90338-07157	.PLUG	2				
4	5UY-27114-00	.STOPPER, MAIN STAND	2				
5	B90-24780-00	SEAT LOCK ASSY	1				
6	95702-06500	NUT, FLANGE	2				
7	1RC-2478X-00	BRACKET, SEAT LOCK	1				
8	95022-06016	BOLT, FLANGE	4				
9	1RC-W2470-00	ROTOR SET	1				
10	95022-06014	BOLT, FLANGE	2				
11	1RC-28100-00	TOOL KIT	1				
12	1RC-28135-00	SPANNER, SPECIAL	1				
13	2H7-28151-00	GRIP, DRIVER	1				
14	2GV-28152-00	DRIVER	1				
15	23P-28164-00	WRENCH, HEXAGON 8	1				
16	4KG-28186-10	POUCH	1				

**FIG. 29 FRONT WHEEL**



**FWD**  
2SCL300-S290

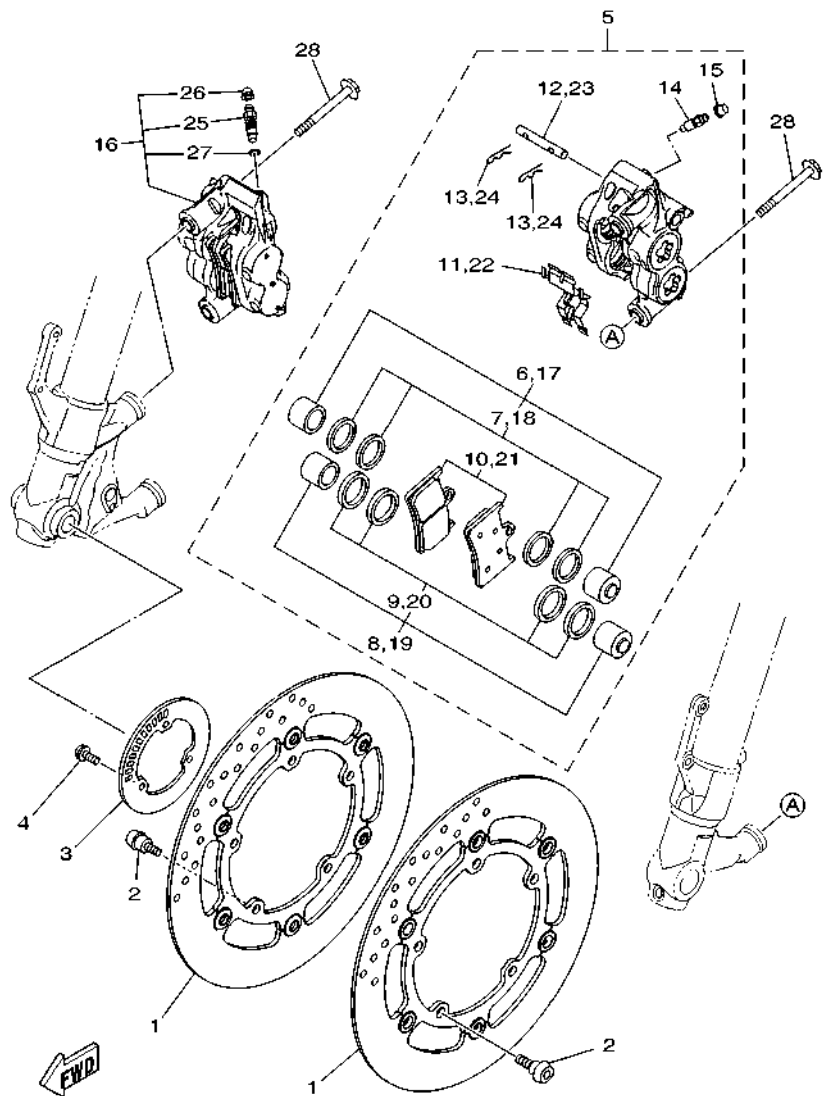
REF. NO.	PART NO.	DESCRIPTION	B2/K2				REMARKS
1	2DR-25168-00-P0	CAST WHEEL, FRONT	1				DPBM15 FOR DPBMC
	2DR-25168-00-P3	CAST WHEEL, FRONT	1				VYRS6 FOR MLNM4
2	2PP-25117-00	SPACER, BEARING	1				
3	93306-20352	BEARING	2				
4	93102-25017	OIL SEAL	2				
5	94112-17126	TIRE (120/70ZR17M/C 58W D214F)	1				UR DUNLOP
	94112-17127	TIRE (120/70ZR17M/C 58W S20F)	1				UR BRIDGESTONE
6	93900-00030	VALVE, RIM (TR412)	1				TAIHEIYO
7	5MT-25398-00	BALANCER, WHEEL (10G)	1				UR
	5MT-25398-10	BALANCER, WHEEL (20G)	1				UR
	5MT-25398-20	BALANCER, WHEEL (30G)	1				UR
8	90387-17017	COLLAR	2				
9	1RC-25181-00	AXLE, WHEEL	1				



BS21300-S300

FIG. 30 FRONT BRAKE CALIPER

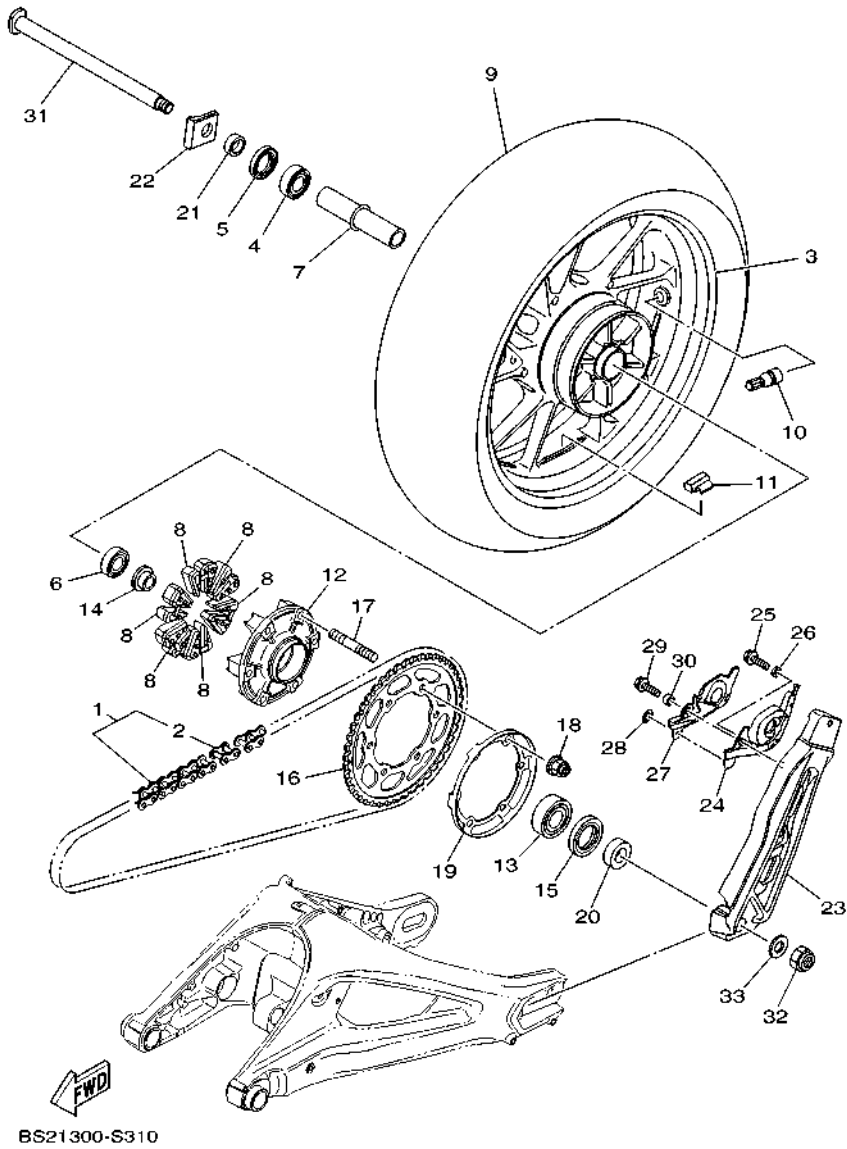
REF. NO.	PART NO.	DESCRIPTION	B2K2	REMARKS
1	1RC-2581T-00	DISK BRAKE ASSY	2	
2	90109-064G6	BOLT	10	
3	2DR-2517G-00	ROTOR, SENSOR	1	
4	90149-05029	SCREW	3	
5	1RC-2580T-00	CALIPER ASSY (LEFT)	1	
6	4SV-25802-10	.PISTON ASSY, CALIPER	1	
7	3GM-25803-10	..CALIPER SEAL KIT	1	
8	4SV-25802-00	.PISTON ASSY, CALIPER	1	
9	3MA-25803-10	..CALIPER SEAL KIT	1	
10	5SL-25805-00	.BRAKE PAD KIT	1	
11	13S-25919-00	.SUPPORT, PAD	1	
12	4SV-25924-00	.PIN, PAD	1	
13	3GM-25925-00	.CLIP	2	
14	1J3-25824-00	.SCREW, BLEED	1	
15	306-25825-01	.CAP	1	
16	2DR-2580U-00	CALIPER ASSY (RIGHT)	1	
17	4SV-25802-10	.PISTON ASSY, CALIPER	1	
18	3GM-25803-10	..CALIPER SEAL KIT	1	
19	4SV-25802-00	.PISTON ASSY, CALIPER	1	
20	3MA-25803-10	..CALIPER SEAL KIT	1	
21	5SL-25805-00	.BRAKE PAD KIT	1	
22	13S-25919-00	.SUPPORT, PAD	1	
23	4SV-25924-00	.PIN, PAD	1	
24	3GM-25925-00	.CLIP	2	
25	5VS-25824-00	.SCREW, BLEED	1	
26	306-25825-01	.CAP	1	
27	5VS-25975-00	.RUBBER, BUSHING	1	



BS21300-S300

FIG. 30 FRONT BRAKE CALIPER

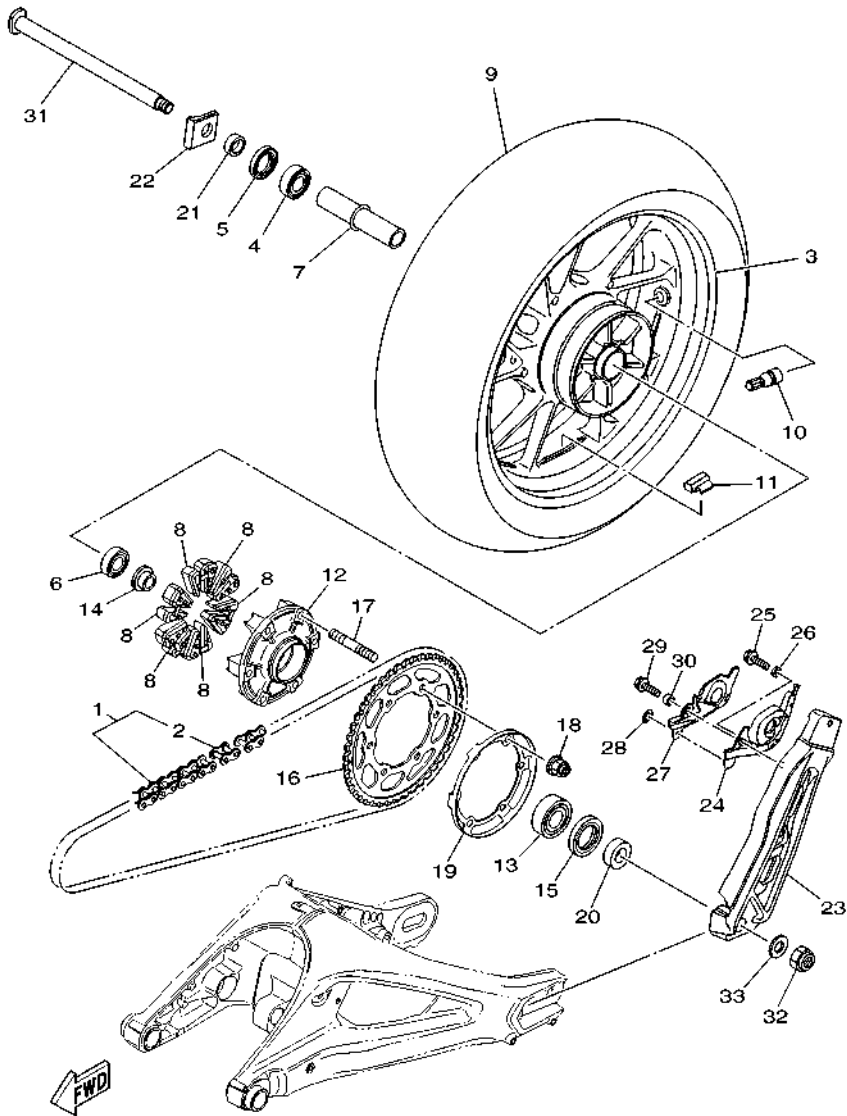
REF. NO.	PART NO.	DESCRIPTION	B2/K2				REMARKS
28	90105-10440	BOLT, FLANGE	4				



**FIG. 31 REAR WHEEL**

REF. NO.	PART NO.	DESCRIPTION	B2/K2	REMARKS
1	94582-31110	CHAIN (DID 525V10-110LL)	1	
2	94682-31031	.JOINT, CHAIN (DID 525V10-ZJ)	1	
3	2DR-25338-00-P0	CAST WHEEL, REAR	1	DPBM15 FOR DPBMC
	2DR-25338-00-P6	CAST WHEEL, REAR	1	VYRS6 FOR MLNM4
4	93306-20480	BEARING	1	
5	93102-28022	OIL SEAL	1	
6	93306-00416	BEARING	1	
7	2PP-25317-00	SPACER, BEARING	1	
8	1RC-25364-00	DAMPER	6	
9	94118-17078	TIRE (180/55ZR17M/C 73W S20R)	1	UR BRIDGESTONE
	94118-17077	TIRE (180/55ZR17M/C 73W D214)	1	UR DUNLOP
10	93900-00030	VALVE, RIM (TR412)	1	TAIHEIYO
11	5MT-25398-00	BALANCER, WHEEL (10G)	1	UR
	5MT-25398-10	BALANCER, WHEEL (20G)	1	UR
	5MT-25398-20	BALANCER, WHEEL (30G)	1	UR
12	5JJ-25366-00	CLUTCH, HUB	1	
13	93306-205B5	BEARING	1	
14	1RC-25383-00	COLLAR, WHEEL	1	
15	93106-40013	OIL SEAL	1	
16	BS2-25445-00	SPROCKET, DRIVEN (45T)	1	
17	90116-10048	BOLT, STUD	6	
18	95602-10200	NUT, S/L FLANGE	6	
19	BS2-2537W-00	BRACKET 1	1	
20	90387-20036	COLLAR	1	
21	90387-20035	COLLAR	1	
22	1RC-25389-00	PULLER, CHAIN 2	1	
23	BS2-25389-00	PULLER, CHAIN 2	1	

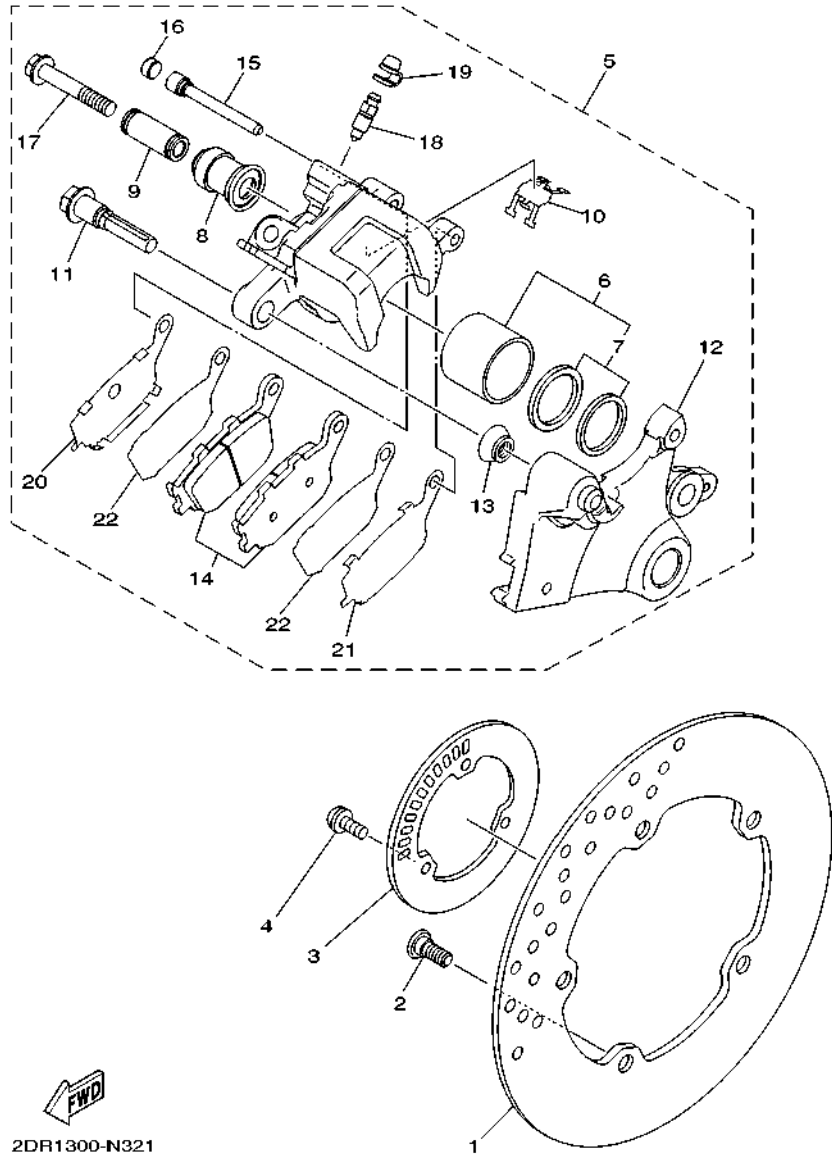




BS21300-S310

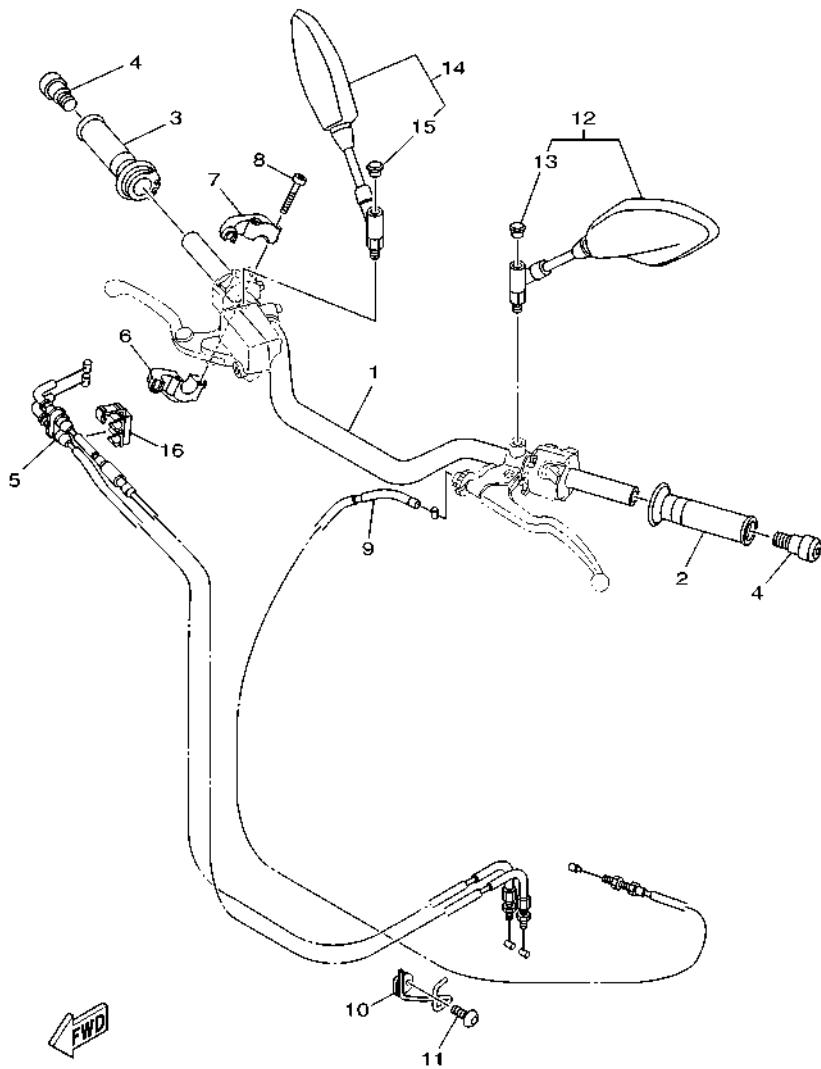
**FIG. 31 REAR WHEEL**

REF. NO.	PART NO.	DESCRIPTION	B2/K2				REMARKS
24	BS2-25715-00	COVER 1	1				
25	95D37-06014	BOLT, FLANGE DEEP RECESS	1				
26	90387-060U2	COLLAR	1				
27	BS2-25716-00	COVER 2	1				
28	90183-05M02	NUT, SPRING	1				
29	95D37-06014	BOLT, FLANGE DEEP RECESS	1				
30	90387-06207	COLLAR	1				
31	BS2-25381-00	AXLE, WHEEL	1				
32	90185-18009	NUT, SELF-LOCKING	1				
33	90201-18021	WASHER, PLATE	1				



**FIG. 32 REAR BRAKE CALIPER**

REF. NO.	PART NO.	DESCRIPTION	B2K2				REMARKS
1	1RC-2582W-00	DISK, REAR BRAKE 2	1				
2	90109-08045	BOLT	5				
3	2DR-2517G-00	ROTOR, SENSOR	1				
4	90149-05029	SCREW	3				
5	2DR-2580W-00	CALIPER ASSY, REAR 2	1				
6	5SL-25802-00	.PISTON ASSY, CALIPER	1				
7	5SL-25803-00	..CALIPER SEAL KIT	1				
8	5SL-25917-00	.BOOT, CALIPER	1				
9	5SL-25838-00	.SLEEVE, CALIPER	1				
10	5SL-25919-00	.SUPPORT, PAD	1				
11	5SL-25914-00	.PIN, SLIDE	1				
12	2DR-25921-50	.BRACKET, SUPPORT	1				
13	3JD-25917-00	.BOOT, CALIPER	1				
14	5VX-25806-00	.BRAKE PAD KIT 2	1				
15	8CR-25924-00	.PIN, PAD	1				
16	5DH-25916-00	.PLUG	1				
17	1RC-25926-00	.BOLT	1				
18	8CR-25824-00	.SCREW, BLEED	1				
19	1UY-25825-51	.CAP	1				
20	5SL-25827-00	.SHIM, CALIPER	1				
21	5SL-25827-10	.SHIM, CALIPER	1				
22	5SL-25828-01	.SHIM, CALIPER	2				

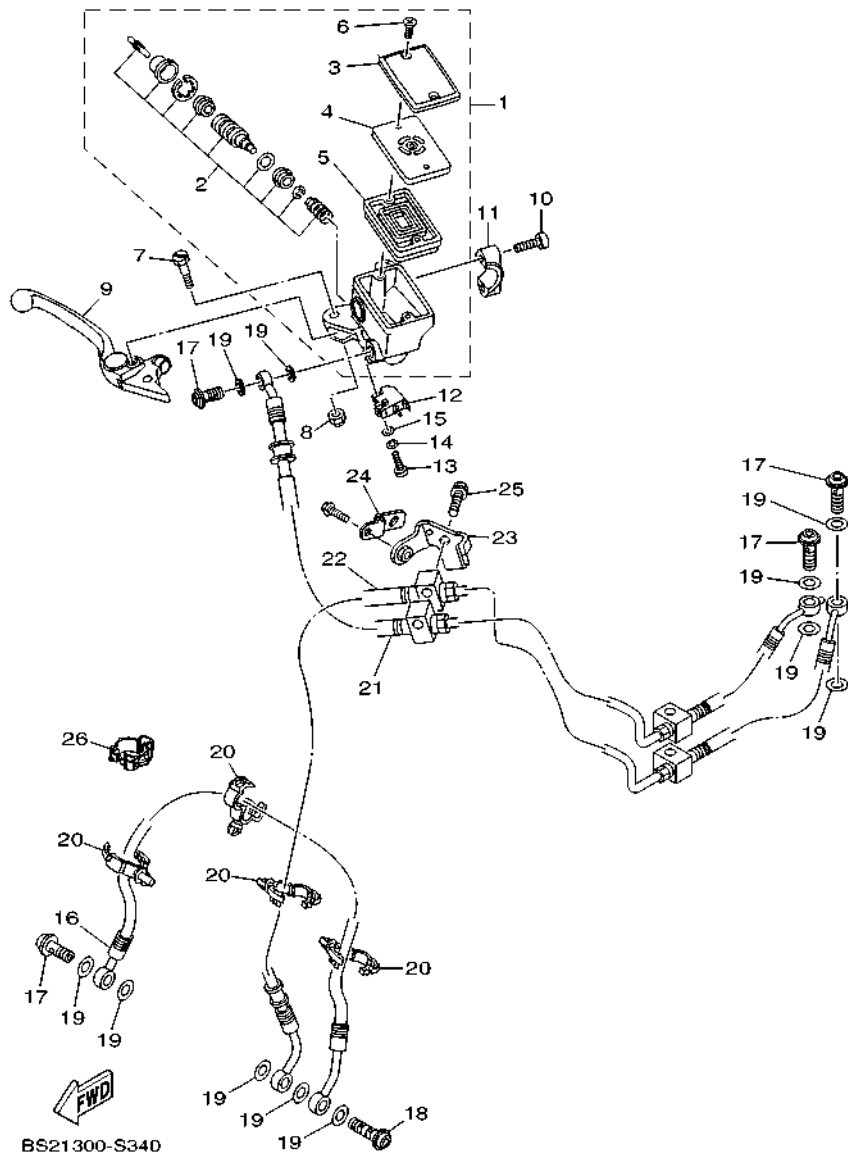


BS23110-S330

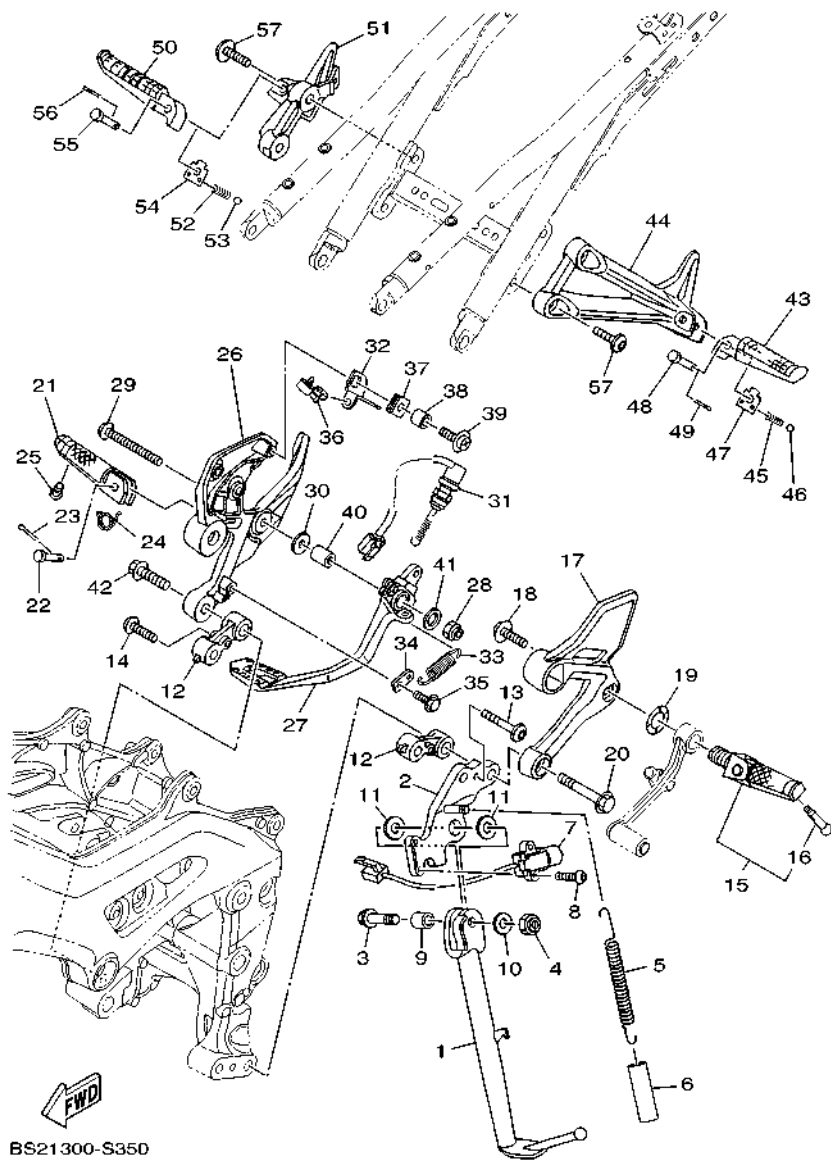
FIG. 33 STEERING HANDLE & CABLE

REF. NO.	PART NO.	DESCRIPTION	B2K2				REMARKS
1	1RC-26111-00	HANDLEBAR	1				
2	4YR-26241-02	GRIP (LEFT)	1				
3	4YR-26240-02	GRIP ASSY	1				
4	5GJ-26246-00	END, GRIP	2				
5	1RC-26302-00	THROTTLE CABLE ASSY	1				
6	4KG-26281-00	CAP GRIP	1				
7	3XW-26282-01	CAP GRIP	1				
8	91317-05035	BOLT,HEX.SOCKET HEAD	2				
9	1RC-26335-01	CABLE, CLUTCH	1				
10	BS2-23857-00	HOLDER	1				
11	92017-06010	BOLT, BUTTON HEAD	1				
12	1RC-26280-00	REAR VIEW MIRROR ASSY (LEFT)	1				
13	23P-26133-00	.CAP	1				
14	1RC-26290-00	REAR VIEW MIRROR ASSY (RIGHT)	1				
15	23P-26133-00	.CAP	1				
16	39P-2627E-00	CLAMP, WIRE	1				

**FIG. 34 FRONT MASTER CYLINDER**



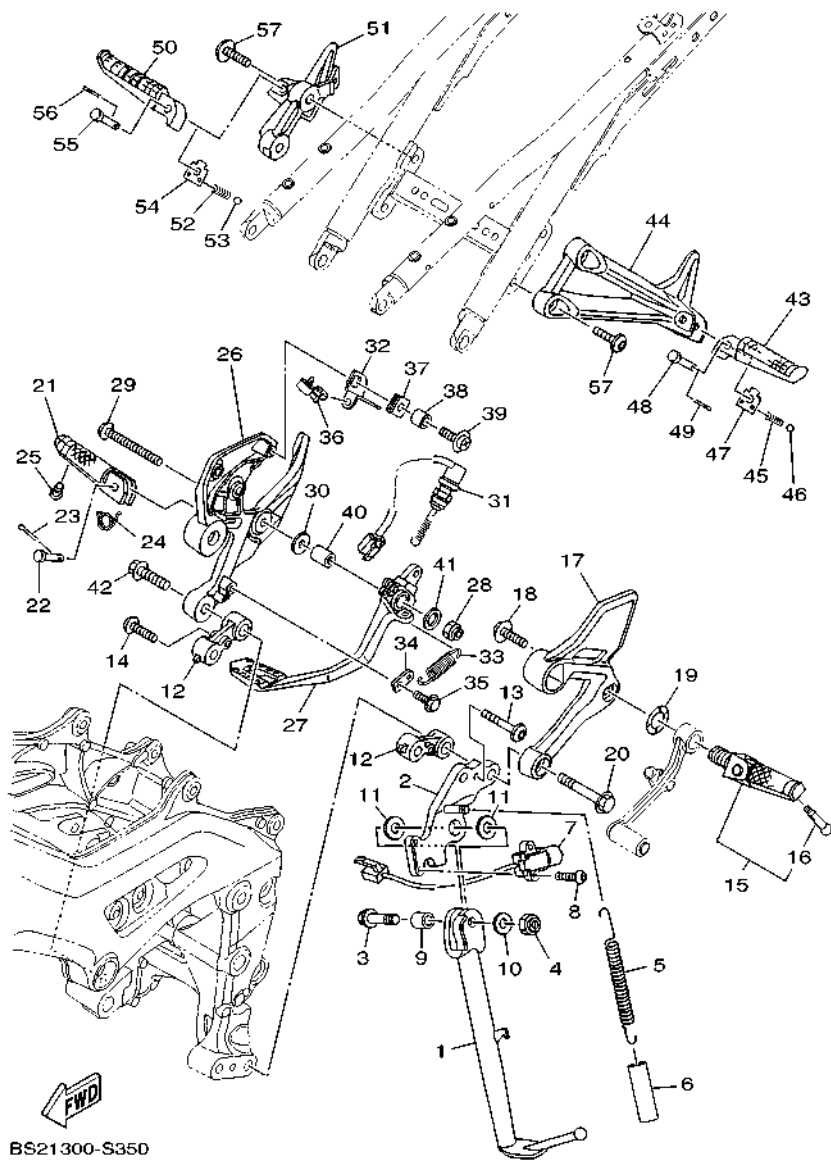
REF. NO.	PART NO.	DESCRIPTION	B2/K2				REMARKS
1	2DR-2580A-00	MASTER CYLINDER SUB ASSY 2	1				
2	1MC-25807-00	.CYLINDER KIT, MASTER	1				
3	5VS-25852-00	.CAP, RESERVOIR	1				
4	5VS-25855-00	.BUSH,DIAPHRAGM	1				
5	20S-25854-00	.DIAPHRAGM, RESERVOIR	1				
6	5VS-2589H-00	.SCREW	2				
7	5VS-2589F-00	BOLT, LEVER	1				
8	95617-06100	NUT, SELF-LOCKING	1				
9	5VS-83922-00	LEVER 2	1				
10	5VS-26332-00	BOLT	2				
11	5VS-25867-00	BRACKET, MASTER CYLINDER	1				
12	1HP-83980-01	FRONT STOP SWITCH ASSY	1				
13	98502-04012	SCREW, PAN HEAD	1				
14	92902-04100	WASHER, SPRING	1				
15	92902-04600	WASHER, PLATE	1				
16	2DR-25872-00	HOSE, BRAKE 1	1				
17	90401-10172	BOLT, UNION	4				
18	90401-10042	BOLT, UNION	1				
19	90430-10005	GASKET	11				
20	90464-18002	CLAMP	4				
21	B6C-2584A-00	BRAKE HOSE ASSY	1				
22	2DR-2584B-00	HOSE, BRAKE	1				
23	2DR-85132-00	BRACKET, REFLECTOR 1	1				
24	B90-2612E-00	BRACKET	1				
25	90105-06192	BOLT, FLANGE	1				
26	90464-14013	CLAMP	1				



BS21 300-S350

FIG. 35 STAND & FOOTREST

REF. NO.	PART NO.	DESCRIPTION	B2/K2	REMARKS
1	1RC-27311-00	STAND, SIDE	1	
2	1RC-27321-00	BRACKET, SIDE STAND	1	
3	90105-10188	BOLT, FLANGE	1	
4	95612-10100	NUT, U	1	
5	90506-20032	SPRING, TENSION	1	
6	90445-197J2	HOSE (L60)	1	
7	1RC-82566-50	SWITCH, SIDE STAND	1	
8	90111-05036	BOLT,HEX. SOCKET BUTTON	2	
9	90387-10050	COLLAR	1	
10	90201-10035	WASHER, PLATE	1	
11	90201-17018	WASHER, PLATE	2	
12	1RC-274A3-00	BRACKET, ADAPTER 1	2	
13	92012-06040	BOLT, BUTTON HEAD	1	
14	92012-06030	BOLT, BUTTON HEAD	1	
15	1RC-27410-00	FRONT FOOTREST ASSY (LEFT)	1	
16	90109-08231	.BOLT	1	
17	1RC-27442-00	BRACKET 2	1	
18	90111-10039	BOLT,HEX. SOCKET BUTTON	1	
19	90206-17084	WASHER, WAVE	1	
20	90105-10377	BOLT, FLANGE	1	
21	3XV-27461-02	FOOTREST	1	
22	91701-08040	PIN	1	
23	91402-25015	PIN, COTTER	1	
24	90508-20572	SPRING, TORSION	1	
25	90109-08231	BOLT	1	
26	BS2-27443-00	BRACKET 3	1	
27	1RC-27200-00	PEDAL, BRAKE	1	



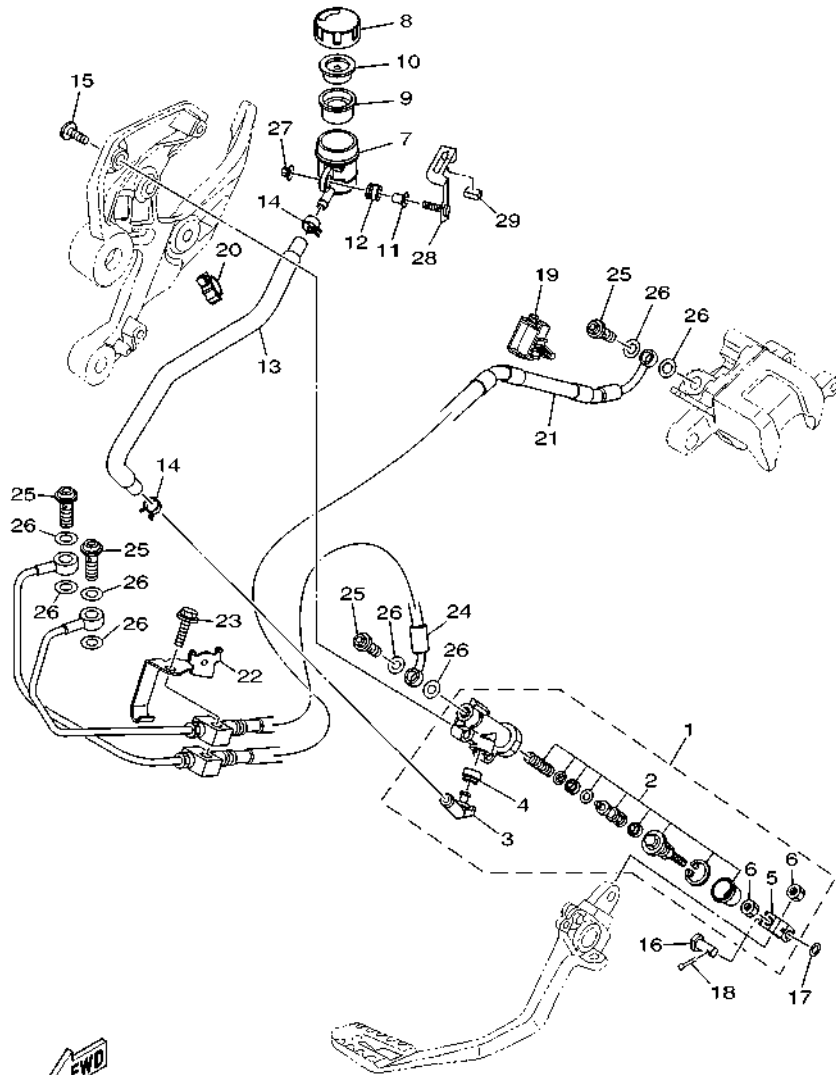
BS21300-S350

FIG. 35 STAND & FOOTREST

REF. NO.	PART NO.	DESCRIPTION	B2K2	REMARKS
28	90185-08089	NUT, SELF-LOCKING	1	
29	90111-08005	BOLT, HEX. SOCKET BUTTON	1	
30	90201-08103	WASHER, PLATE	1	
31	B90-82530-00	STOP SWITCH ASSY	1	
32	1RC-2144G-00	STAY, STOP SWITCH	1	
33	90506-23008	SPRING, TENSION	1	
34	1RC-27432-00	BRACKET 1	1	
35	95D02-06010	BOLT, FLANGE DEEP RECESS	1	
36	90464-15157	CLAMP	1	
37	90480-12607	GROMMET	1	
38	90387-06M16	COLLAR	1	
39	90159-06150	SCREW, WITH WASHER	1	
40	90387-08102	COLLAR	1	
41	90201-08048	WASHER, PLATE	1	
42	90105-10252	BOLT, FLANGE	1	
43	3VR-27431-02	FOOTREST, REAR 1	1	
44	1RC-2741L-01	BRACKET 4	1	
45	90501-12743	SPRING, COMPRESSION	1	
46	93501-04011	BALL	1	
47	5VX-27437-00	WASHER, SPECIAL	1	
48	91702-08040	PIN, CLEVIS	1	
49	91401-25015	PIN, COTTER	1	
50	3VR-27441-02	FOOTREST, REAR 2	1	
51	1RC-2742L-01	BRACKET 5	1	
52	90501-12743	SPRING, COMPRESSION	1	
53	93501-04011	BALL	1	
54	5VX-27437-00	WASHER, SPECIAL	1	



**FIG. 36 REAR MASTER CYLINDER**

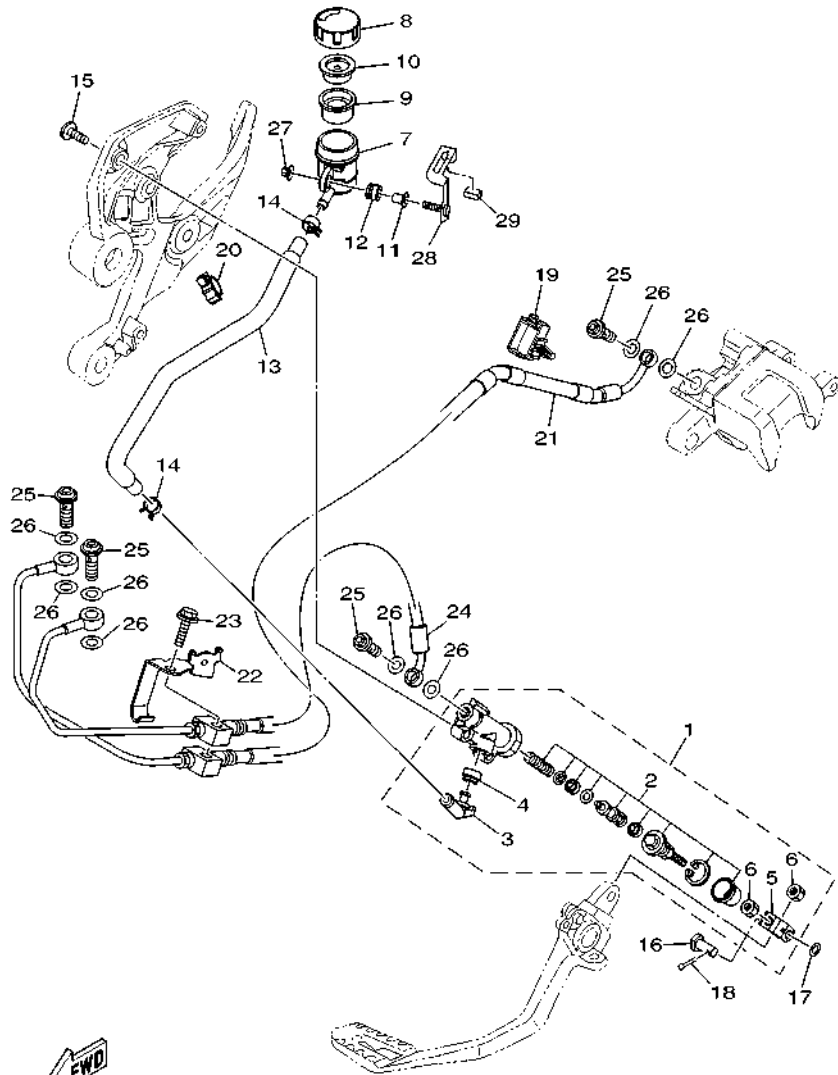


BS21300-S360

REF. NO.	PART NO.	DESCRIPTION	B2K2				REMARKS
1	56P-2583V-00	RR. MASTER CYLINDER ASSY.	1				
2	56P-25808-50	.CYLINDER KIT, MASTER	1				
3	2D1-2582A-00	.JOINT	1				
4	4BP-2585F-01	.O-RING	1				
5	4BP-27222-02	.JOINT	1				
6	90170-08010	.NUT	2				
7	14B-25894-00	TANK, RESERVOIR	1				
8	2C0-25852-00	CAP, RESERVOIR	1				
9	2VN-25854-00	DIAPHRAGM, RESERVOIR	1				
10	2VN-25855-00	BUSH,DIAPHRAGM	1				
11	90387-05028	COLLAR	1				
12	2C0-26326-00	GROMMET	1				
13	1RC-25895-00	HOSE, RESERVOIR	1				
14	90467-120A3	CLIP	2				
15	90111-08038	BOLT,HEX. SOCKET BUTTON	2				
16	90240-08005	PIN, CLEVIS	1				
17	90201-08066	WASHER, PLATE	1				
18	91401-20012	PIN, COTTER	1				
19	90464-20023	CLAMP	1				
20	90464-18007	CLAMP	1				
21	2DR-2581K-00	HOSE, BRAKE 5	1				
22	2DR-85142-00	BRACKET, REFLECTOR 2	1				
23	90105-06192	BOLT, FLANGE	1				
24	2DR-2581J-00	HOSE, BRAKE 4	1				
25	90401-10172	BOLT, UNION	4				
26	90430-10005	GASKET	8				
27	95707-05500	NUT, FLANGE	1				



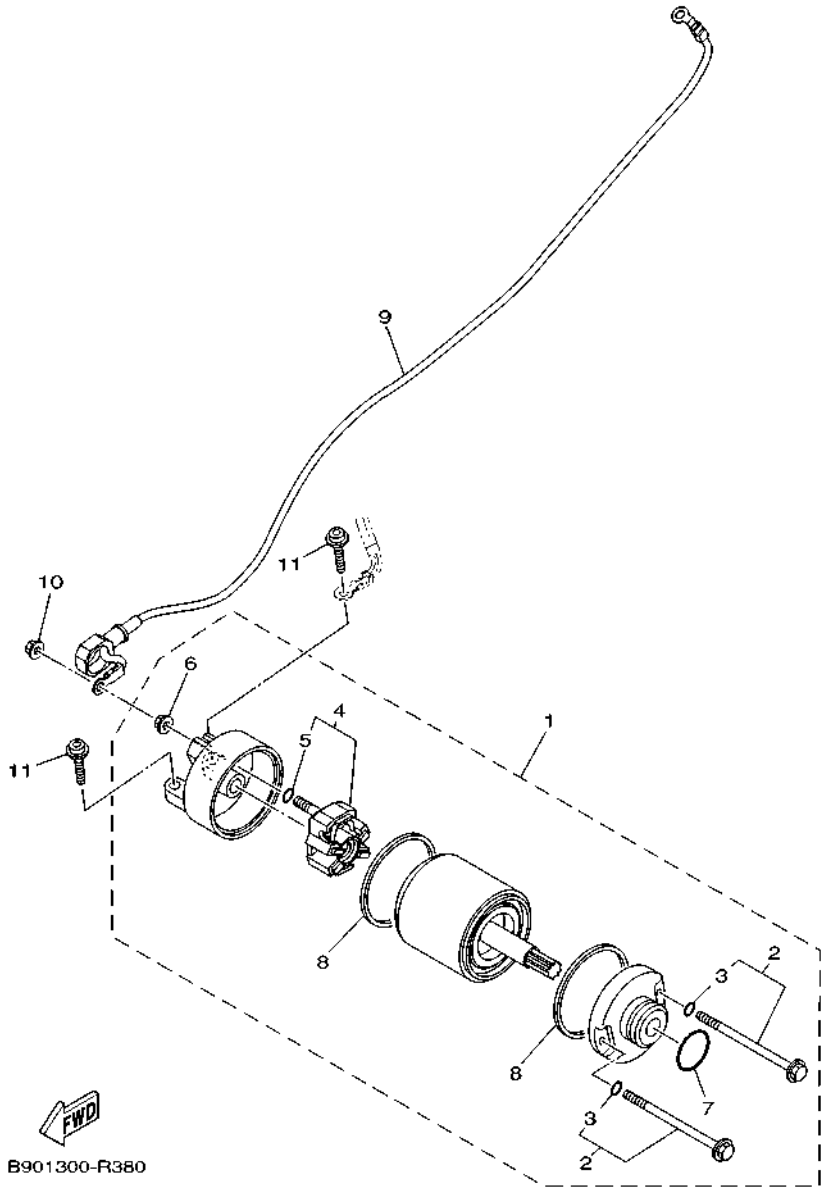
**FIG. 36 REAR MASTER CYLINDER**



BS21300-S360

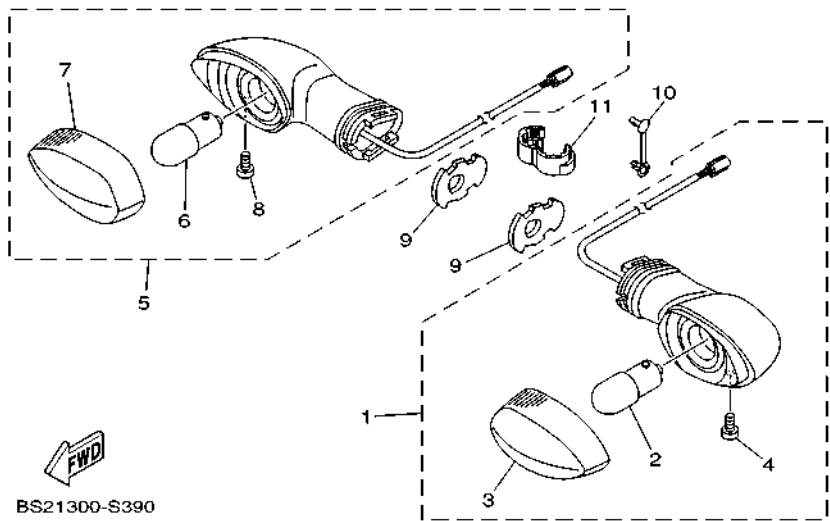
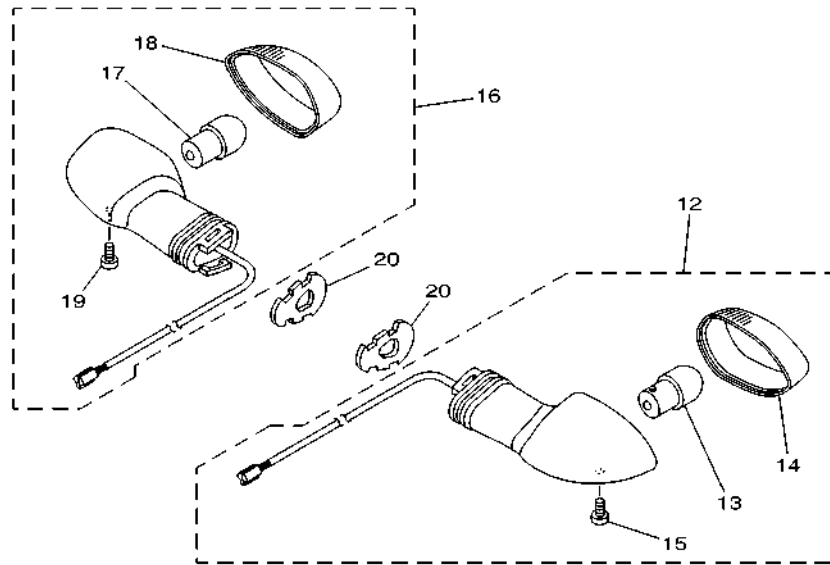
REF. NO.	PART NO.	DESCRIPTION	B2/K2				REMARKS
28	1RC-2582E-00	HOLDER, RESERVE TANK	1				
29	90520-02005	DAMPER, PLATE	1				
<hr/>							
<hr/>							
<hr/>							
<hr/>							
<hr/>							
<hr/>							
<hr/>							
<hr/>							
<hr/>							





**FIG. 38 STARTING MOTOR**

REF. NO.	PART NO.	DESCRIPTION	B2K2				REMARKS
1	1RC-81890-00	MOTOR ASSY	1				
2	28P-81826-00	.BOLT	2				
3	3TB-81847-00	.O-RING	1				
4	4B5-81840-00	.BRUSH HOLDER ASSY	1				
5	3TB-81847-00	.O-RING	1				
6	4XV-8182A-00	.NUT	1				
7	1FK-81847-00	.O-RING	1				
8	11H-81844-00	.GASKET	2				
9	1RC-81815-00	CORD, STARTER MOTOR	1				
10	4XV-8182A-00	NUT	1				
11	90110-06388	BOLT, HEXAGON SOCKET HEAD	2				

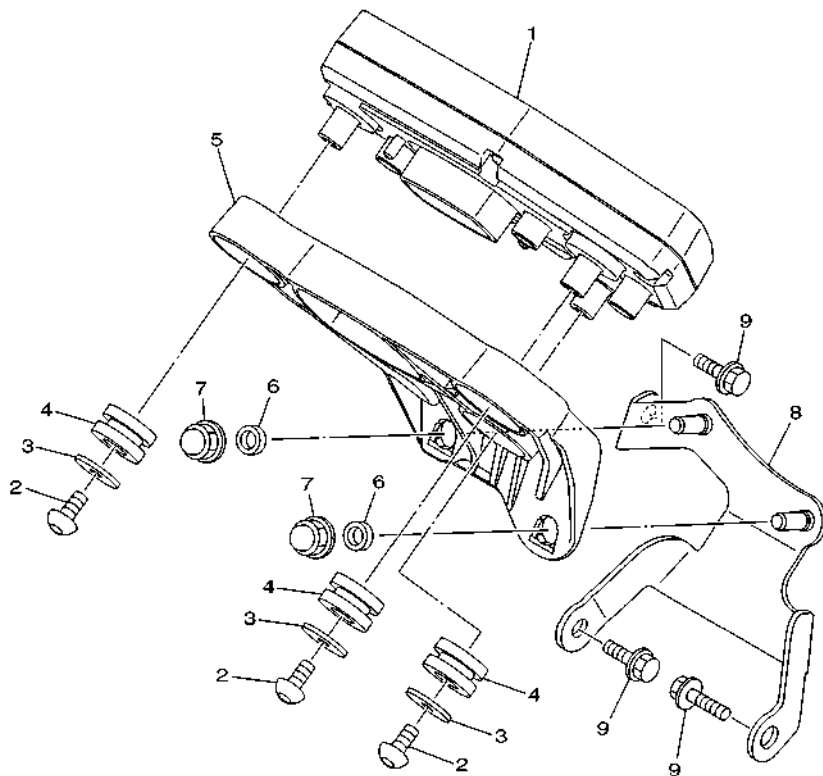


BS21300-S390

FIG. 39 FLASHER LIGHT

REF. NO.	PART NO.	DESCRIPTION	B2/K2				REMARKS
1	BS2-83310-00	FRONT FLASHER LIGHT ASSY 1	1				
2	1KB-83311-00	.BULB, FLASHER (12V-10W)	1				
3	1KB-8333A-00	.LENS COMP 1	1				
4	3D9-H3333-10	.SCREW, LENS FITTING	1				
5	BS2-83320-00	FRONT FLASHER LIGHT ASSY 2	1				
6	1KB-83311-00	.BULB, FLASHER (12V-10W)	1				
7	1KB-8334A-00	.LENS COMP 2	1				
8	3D9-H3333-10	.SCREW, LENS FITTING	1				
9	3D7-83318-10	STAY, FLASHER 1	2				
10	90464-05003	CLAMP	1				
11	90464-13227	CLAMP	1				
12	BS2-83330-00	REAR FLASHER LIGHT ASSY 1	1				
13	1KB-83311-00	.BULB, FLASHER (12V-10W)	1				
14	1KB-8334A-00	.LENS COMP 2	1				
15	3D9-H3333-10	.SCREW, LENS FITTING	1				
16	BS2-83340-00	REAR FLASHER LIGHT ASSY 2	1				
17	1KB-83311-00	.BULB, FLASHER (12V-10W)	1				
18	1KB-8333A-00	.LENS COMP 1	1				
19	3D9-H3333-10	.SCREW, LENS FITTING	1				
20	3D7-83318-10	STAY, FLASHER 1	2				

**FIG. 40 METER**



REF. NO.	PART NO.	DESCRIPTION	B2/K2				REMARKS
1	BS2-83500-00	METER ASSY (KM/H)	1				
2	90160-05017	SCREW, ROUND TAPPING	3				
3	90201-05036	WASHER, PLATE	3				
4	4XV-83513-00	DAMPER	3				
5	BS2-83559-00	COVER, METER	1				
6	90387-07015	COLLAR	2				
7	90176-06009	NUT, CROWN	2				
8	BS2-83519-00	BRACKET, METER	1				
9	95027-06010	BOLT, FLANGE	3				

  
BS21300-S400

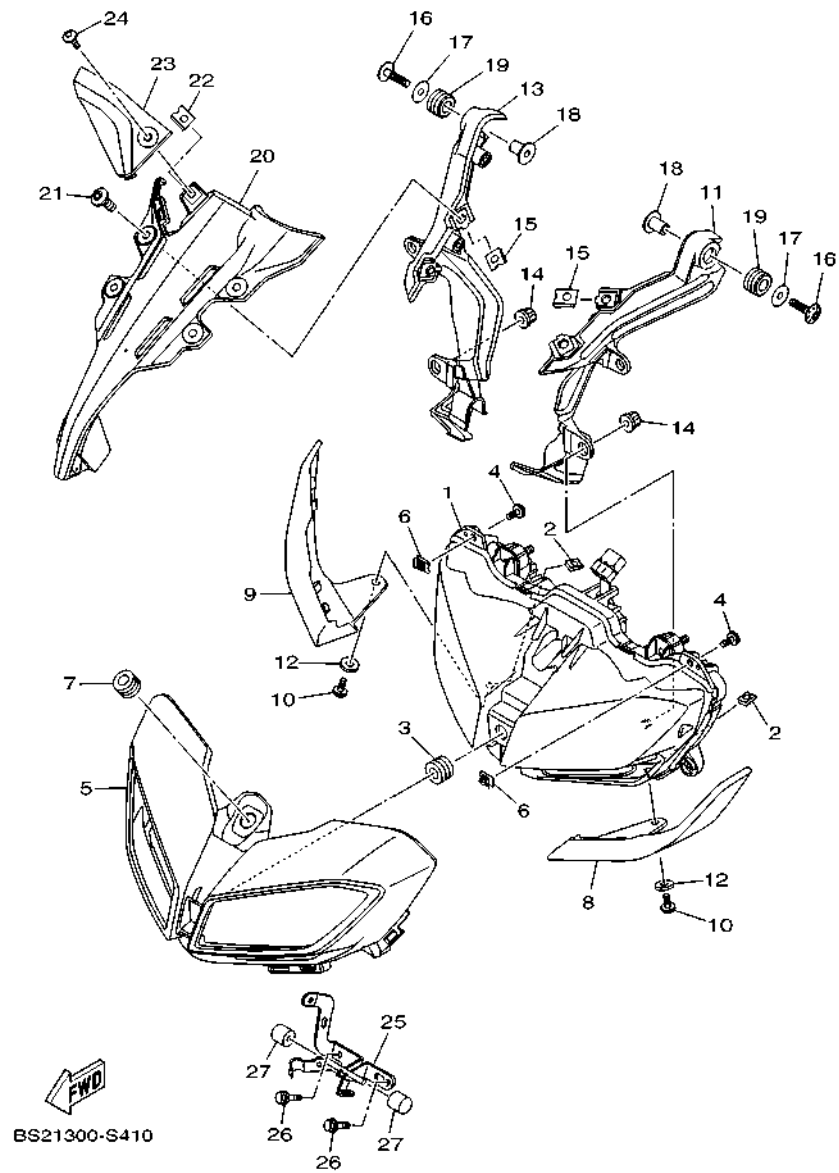


FIG. 41 HEADLIGHT

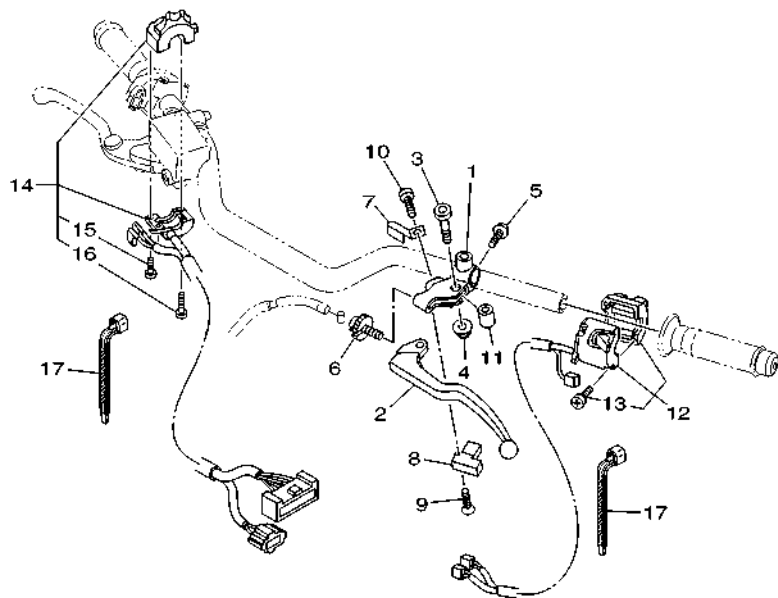
REF. NO.	PART NO.	DESCRIPTION	B2K2	REMARKS
1	BS2-84300-00	HEADLIGHT ASSY	1	
2	90183-05042	NUT, SPRING	2	
3	90480-13398	GROMMET	1	
4	90167-05080	SCREW, TAPPING	4	
5	BS2-2838D-00	COVER, HEADLIGHT 1	1	
6	90183-05042	NUT, SPRING	2	
7	90480-13398	GROMMET	1	
8	BS2-2830C-00-P1	VISOR, SIDE 1	1	UR FOR DPBMC
	BS2-2830C-00-P9	VISOR, SIDE 1	1	UR FOR MLNM4
9	BS2-2830D-00-P1	VISOR, SIDE 2	1	UR FOR DPBMC
	BS2-2830D-00-P9	VISOR, SIDE 2	1	UR FOR MLNM4
10	90167-05080	SCREW, TAPPING	2	
11	BS2-2831V-00	STAY, HEAD LIGHT 1	1	
12	90202-05180	WASHER, PLATE	2	
13	BS2-2832V-00	STAY, HEAD LIGHT 2	1	
14	90179-06074	NUT	4	
15	90183-061A4	NUT, SPRING	4	
16	90109-06317	BOLT	2	
17	90201-06063	WASHER, PLATE	2	
18	90387-06136	COLLAR	2	
19	90480-14102	GROMMET	2	
20	BS2-23391-00	PANEL, FRONT	1	
21	90111-06127	BOLT,HEX. SOCKET BUTTON	4	
22	90183-05076	NUT, SPRING	1	
23	BS2-23397-00	PANEL, FRONT 2	1	
24	90111-05002	BOLT,HEX. SOCKET BUTTON	1	
25	BS2-8431R-00	STAY, SETTING	1	





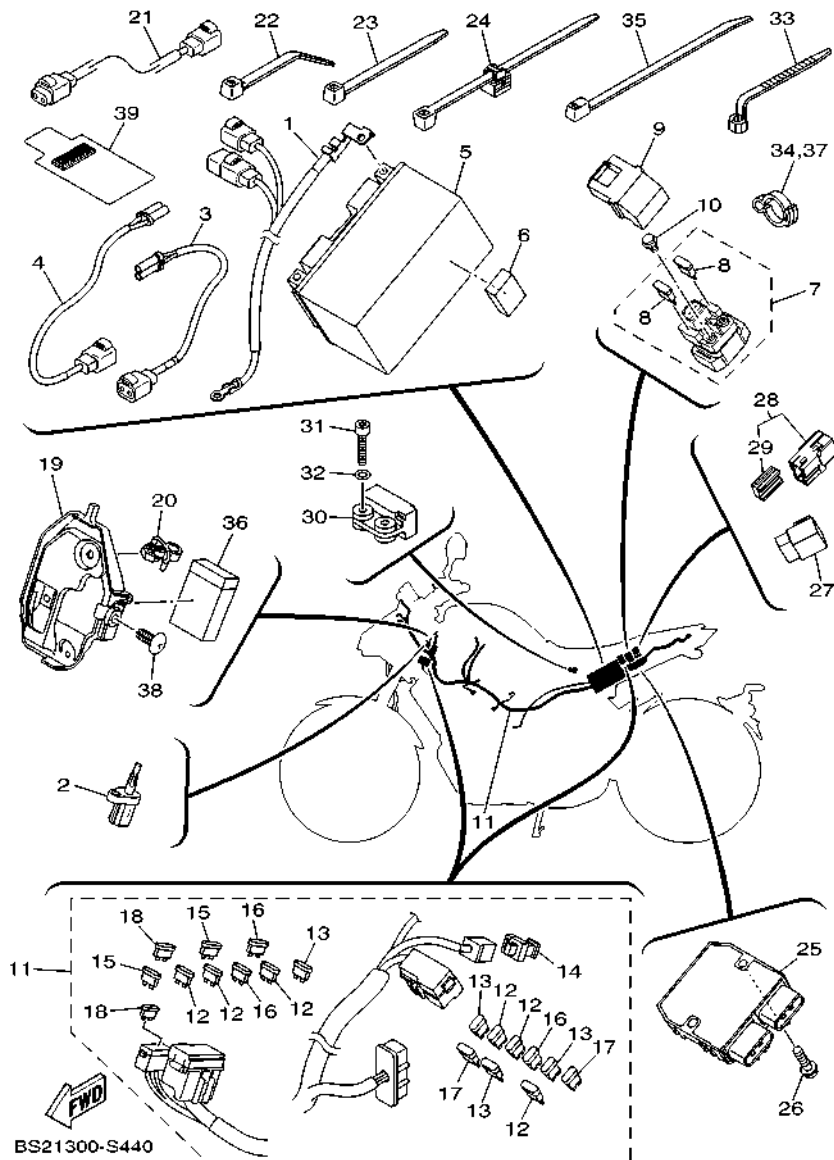


**FIG. 43 HANDLE SWITCH & LEVER**



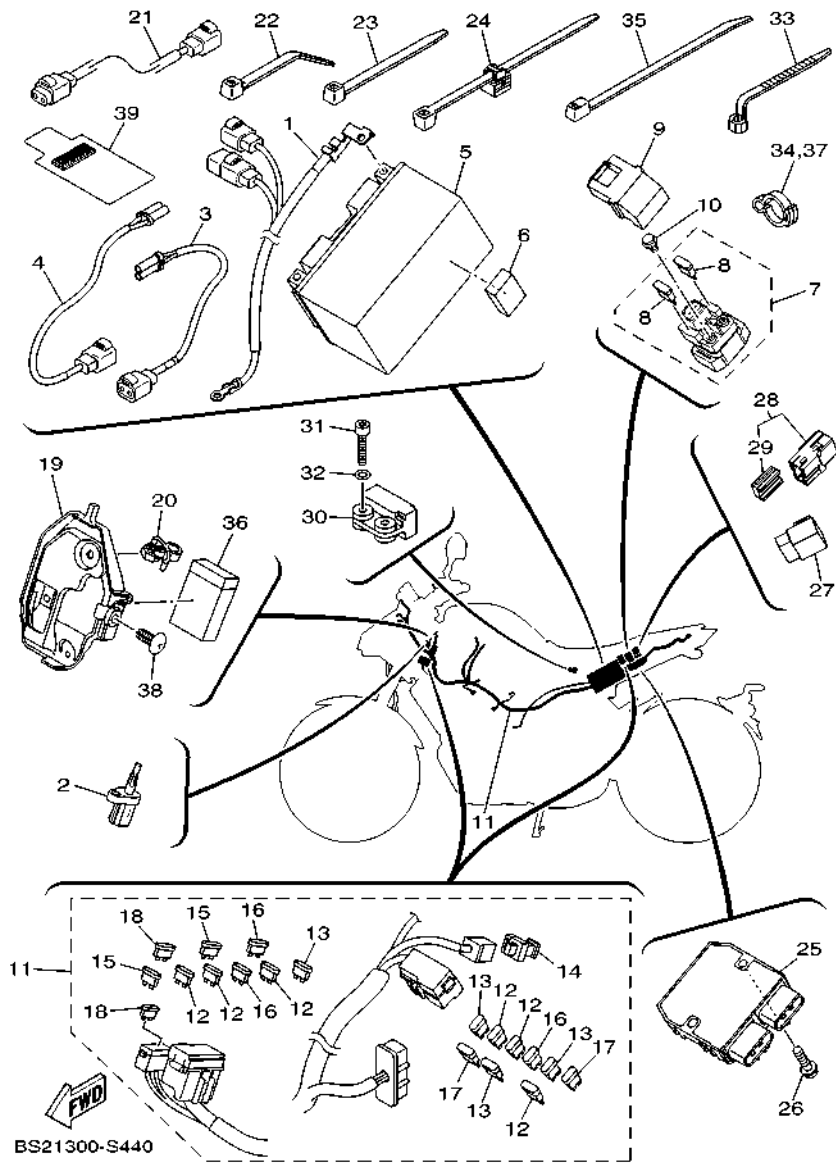
REF. NO.	PART NO.	DESCRIPTION	B2K2				REMARKS
1	1B3-82911-00	HOLDER, LEVER 1	1				
2	5EB-83912-03	LEVER 1	1				
3	2C0-83945-00	BOLT, LEVER	1				
4	95607-06200	NUT, SELF U-FLANGE	1				
5	95027-06020	BOLT, FLANGE	1				
6	5LV-83951-00	BOLT, CABLE ADJUSTING	1				
7	4XV-83929-00	PLATE, SPRING	1				
8	3YX-82917-01	SWITCH	1				
9	98704-03020	SCREW, FLAT HEAD	1				
10	98507-04010	SCREW, PAN HEAD	1				
11	5JJ-83913-00	COLLAR, LEVER 1	1				
12	BS2-83969-00	SWITCH, HANDLE 5	1				
13	98507-04025	.SCREW, PAN HEAD	2				
14	BS2-83963-10	SWITCH, HANDLE 3	1				
15	98507-04020	.SCREW, PAN HEAD	1				
16	98507-04030	.SCREW, PAN HEAD	1				
17	90464-13073	CLAMP	2				(125.0x7.0)

  
BS21300-S430



**FIG. 44 ELECTRICAL 1**

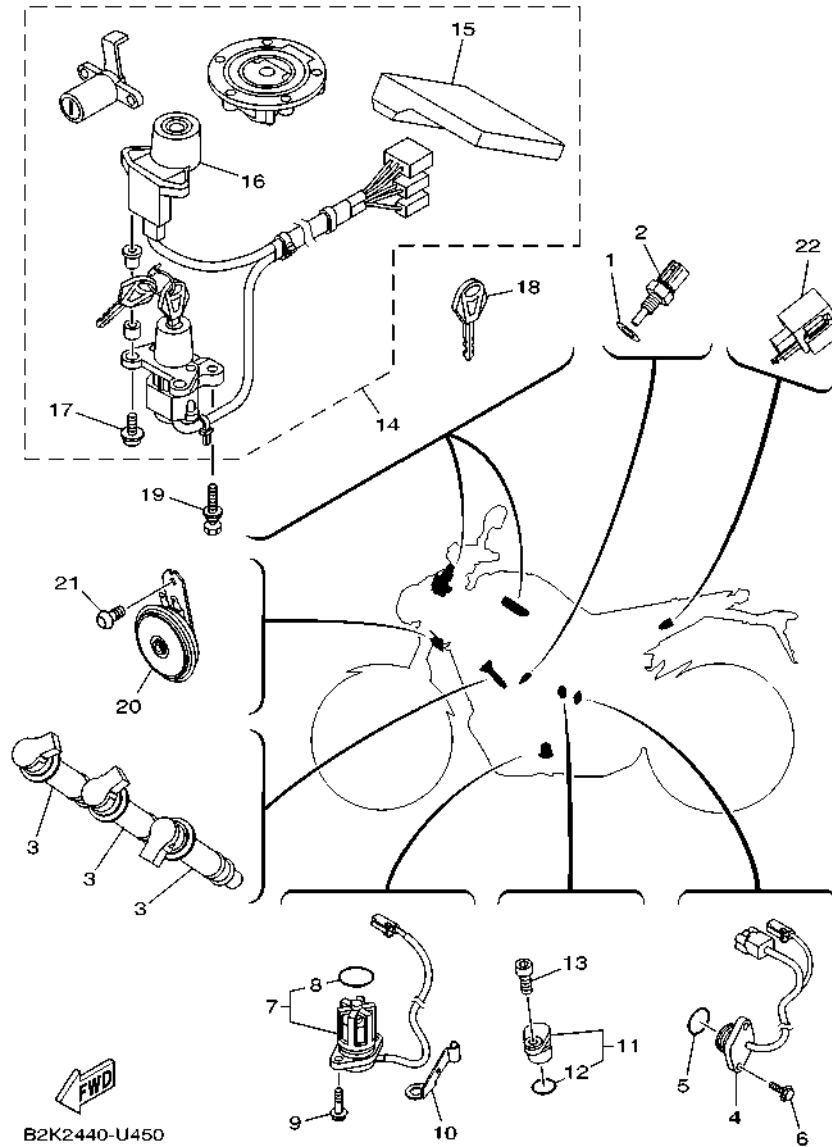
REF. NO.	PART NO.	DESCRIPTION	B2K2	REMARKS
1	BS2-82116-00	WIRE, MINUS LEAD	1	
2	5YU-85886-00	SENSOR, AIR TEMPERATURE	1	
3	1RC-82309-01	WIRE, SUB LEAD	1	
4	1RC-82509-00	WIRE, SUB LEAD	1	
5	5VY-82100-00	BATTERY ASSY (YUASA YTZ10S)	1	
6	4D3-8252R-00	DAMPER	1	
7	1RC-81940-00	STARTER RELAY ASSY	1	
8	42X-82151-00	.FUSE (10A-BL)	2	
9	5SL-82119-30	COVER, LEAD WIRE	1	
10	95022-06008	BOLT, FLANGE	2	
11	BS2-82590-00	WIRE HARNESS ASSY	1	
12	5JJ-82151-00	.FUSE (7.5A-BL)	6	
13	5JJ-82151-10	.FUSE (15A-BL)	4	
14	5JW-82151-10	.FUSE (50A)	1	
15	5JJ-82151-30	.FUSE (10A-BL)	2	
16	5JJ-82151-80	.FUSE (2A-BL)	3	
17	5JJ-82151-60	.FUSE (30A-BL)	2	
18	5JJ-82151-90	.FUSE (5A-BL)	2	
19	1RC-82599-00	COVER, CONNECTOR	1	
20	90464-15157	CLAMP	1	
21	BS2-82318-00	WIRE, SUB-LEAD	1	
22	90465-10098	CLAMP	1	
23	90464-16061	CLAMP	1	
24	90464-45007	CLAMP	1	
25	1D7-81960-01	RECTIFIER & REGULATOR ASSY	1	
26	95022-06025	BOLT, FLANGE	2	
27	5VK-81950-40	RELAY ASSY (5VK-40)	1	



**FIG. 44 ELECTRICAL 1**

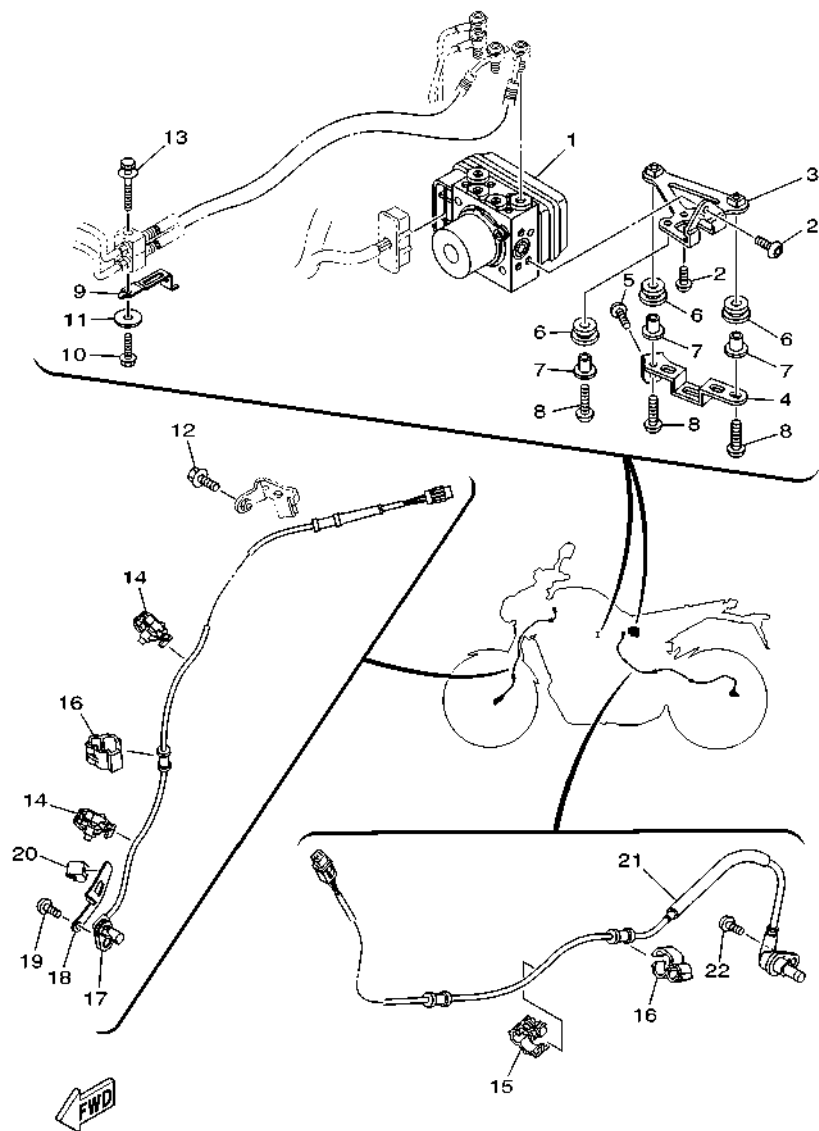
REF. NO.	PART NO.	DESCRIPTION	B2/K2	REMARKS
28	1ST-81950-00	RELAY ASSY (1ST-00)	1	
29	5JJ-81952-00	.HOLDER, RELAY	1	
30	5PS-82576-01	SENSOR, LEAN ANGLE	1	
31	91312-04020	BOLT, HEXAGON SOCKET HEAD	2	
32	90201-04030	WASHER, PLATE	2	
33	90464-13073	CLAMP	1	(125.0x7.0)
34	90464-14010	CLAMP	1	
35	90464-20022	CLAMP	1	
36	1RC-82589-00	PROTECTOR, WIRE HARNESS	1	
37	90464-14010	CLAMP	1	
38	90269-07015	RIVET	1	
39	2D1-82589-00	PROTECTOR, WIRE HARNESS	1	

FIG. 45 ELECTRICAL 2



REF. NO.	PART NO.	DESCRIPTION	B2K2				REMARKS
1	90430-10004	GASKET	1				
2	4P9-83591-00	THERMO UNIT	1				
3	1RC-82310-00	IGNITION COIL ASSY	3				
4	1RC-82540-00	NEUTRAL SWITCH ASSY	1				
5	93210-21001	O-RING	1				
6	90110-05067	BOLT, HEXAGON SOCKET HEAD	2				
7	5S7-85720-00	OIL LEVEL GAUGE ASSY	1				
8	5VY-8A8E0-00	.O-RING	1				
9	95022-06016	BOLT, FLANGE	2				
10	90465-08053	CLAMP	1				
11	3P6-15399-00	PLUG, BLIND	1				
12	93210-15566	.O-RING	1				
13	90110-06161	BOLT, HEXAGON SOCKET HEAD	1				
14	BAE-W8250-00	MAIN SW. IMMOBILIZER KIT	1				
15	BS2-8591A-00	.ENGINE CONTROL UNIT ASSY	1				
16	BAE-8255P-00	.IMMOBILIZER. UNIT COMP.	1				
17	5SL-82113-01	.SCREW	2				
18	5SL-82511-08	BLANK KEY	1				AP
19	90109-08196	BOLT	2				
20	BS2-83371-00	HORN	1				
21	92017-06010	BOLT, BUTTON HEAD	1				
22	4GY-83350-00	FLASHER RELAY ASSY	1				

**FIG. 46 ELECTRICAL 3**



BS21300-S460

REF. NO.	PART NO.	DESCRIPTION	B2K2				REMARKS
1	B50-85930-09	HYDRAULIC UNIT ASSY	1				
2	92012-06010	BOLT, BUTTON HEAD	2				
3	2DR-85991-00	BRACKET, UNIT	1				
4	2DR-85542-00	BRACKET	1				
5	92012-06010	BOLT, BUTTON HEAD	1				
6	90480-13567	GROMMET	3				
7	90387-06160	COLLAR	3				
8	92012-06020	BOLT, BUTTON HEAD	3				
9	BS2-85132-00	BRACKET, REFLECTOR 1	1				
10	95022-06025	BOLT, FLANGE	1				
11	90201-087P8	WASHER, PLATE	1				
12	95827-06020	BOLT, FLANGE	1				
13	90119-06M55	BOLT, WITH WASHER	1				
14	90464-12013	CLAMP	2				
15	90464-14003	CLAMP	1				
16	90464-10233	CLAMP	2				
17	BS2-85970-00	WHEEL SENSOR ASSY, FRONT	1				
18	BS2-85542-00	BRACKET	1				
19	92017-06016	BOLT, BUTTON HEAD	1				
20	90464-05188	CLAMP	1				
21	2DR-85980-01	WHEEL SENSOR ASSY, REAR	1				
22	92014-06014	BOLT, BUTTON HEAD	1				

NUMERICAL INDEX

PART NO.	REF. NO.	PART NO.	REF. NO.	PART NO.	REF. NO.	PART NO.	REF. NO.	PART NO.	REF. NO.	PART NO.	REF. NO.
B90-11101-09	1 - 1	1HX-12168-U1	3 - 9	BS2-12637-00	6 - 13	5VY-14747-00	12 - 7	1TD-16324-00	16 - 7	1RC-18540-00	18 - 1
5VY-1111G-00	1 - 11	1HX-12168-W1	3 - 9	3D8-12675-00	6 - 3	5VY-1482K-00	1 - 17	BR9-16324-00	16 - 14	3D7-18542-00	18 - 3
	1 - 28	1HX-12168-Y1	3 - 9	5VY-13117-10	7 - 9	5JW-1482K-01	1 - 16		16 - 15	1RC-18562-00	18 - 10
	1 - 30	1HX-12169-11	3 - 9	1RC-13300-00	7 - 1	2S3-14840-00	11 - 1	4B1-16325-00	16 - 14	1RC-21110-80	20 - 1
2C0-11133-11	1 - 2	1HX-12169-31	3 - 9	1RC-13355-00	7 - 2	1RC-14881-00	11 - 2		16 - 15	BS2-2117E-00	21 - 16
B90-11165-00	1 - 23	1HX-12169-50	3 - 9	B56-13400-10	8 - 3	1RC-14882-00	11 - 4	5VY-16325-00	16 - 6	1RC-2117G-00	20 - 15
BD5-11167-00	1 - 26	1HX-12169-70	3 - 9	1RC-13410-00	7 - 6	1RC-14883-00	11 - 6		16 - 14	1RC-2117X-00	20 - 4
1RC-11169-00	1 - 24	1HX-12169-90	3 - 9	BD5-13414-00	8 - 6	5JW-14889-00	1 - 21		16 - 15	1RC-2117Y-00	20 - 5
BS2-11181-00	1 - 12	1HX-12169-E0	3 - 9	5GH-13440-60	8 - 2	5PS-14890-00	1 - 20	B90-16331-00	16 - 5	BS2-21190-00	20 - 2
1RC-11191-00	1 - 13	1HX-12169-G0	3 - 9	BS2-13470-00	8 - 10	5SL-14890-00	1 - 18	2CR-16337-00	16 - 11	5UY-21269-00	21 - 4
1RC-11193-01	1 - 15	1HX-12169-J0	3 - 9	2HC-13473-00	8 - 11	5SL-14899-00	1 - 19	1RC-16340-00	16 - 22	5VX-21289-00	20 - 13
214-11198-01	8 - 5	1HX-12169-L0	3 - 9	1RC-13542-00	9 - 4	BS2-15100-09	13 - 1	132-16346-00	19 - 2	BS2-2137W-00-P0	22 - 12
1RC-11400-00	2 - 1	1HX-12169-N0	3 - 9	1RC-13544-00	9 - 2	5EB-15155-00	13 - 2	B90-16350-10	16 - 8	BS2-2137X-00-P0	22 - 29
2S3-11413-00	2 - 14	1HX-12169-T0	3 - 9	1RC-13556-00	10 - 6	23P-15156-00	13 - 9	B90-16352-00	16 - 10	1RC-2144G-00	35 - 32
2S3-11413-10	2 - 14	1RC-12170-00	4 - 1	8FP-13556-00	10 - 7	1RC-15163-00	17 - 2	4XV-16356-01	16 - 21	1RC-21495-00	20 - 8
2S3-11413-20	2 - 14	20S-12176-00	4 - 3	1RC-13573-00	10 - 10	36Y-15189-00	13 - 18	B90-16371-10	16 - 3	4C8-21495-00	20 - 12
2S3-11413-30	2 - 14	1RC-12180-00	4 - 2	1RC-13635-00	10 - 1	1RC-15191-00	14 - 26	5VY-16382-10	16 - 31	1RC-21511-00-33	21 - 1
2S3-11413-40	2 - 14	B90-12210-00	4 - 6	B90-13750-00	9 - 1	1RC-15199-00	14 - 15	1TD-16383-00	16 - 12	1RC-21511-00-PF	21 - 1
5VY-11416-00	2 - 5	1WS-12213-00	4 - 9	4C8-13761-00	10 - 8	B90-15316-00	14 - 17	1TD-16384-00	16 - 13	4C8-21568-10	27 - 47
5VY-11416-10	2 - 5	5SL-12214-00	4 - 8	1RC-13907-00	27 - 18	B90-15326-00	14 - 25	1RC-17121-00	17 - 13	BS2-21613-00	21 - 29
5VY-11416-20	2 - 5	5EL-12228-00	4 - 7	1RC-13930-00	10 - 3	2H7-15361-00	13 - 17	1RC-17131-00	17 - 8	BS2-21614-00	21 - 31
5VY-11416-30	2 - 5	5BE-12241-00	1 - 14	1RC-13938-00	10 - 5	5GJ-15363-10	14 - 27	1RC-17151-00	17 - 5	BS2-21629-01	21 - 18
5VY-11416-A0	2 - 5	1RC-12250-01	4 - 12	1RC-13971-10	27 - 29	1RC-15377-00	13 - 24	1RC-17161-00	17 - 10	2MG-21639-00	21 - 19
1RC-11500-00	2 - 13	1RC-12251-00	4 - 11	2C0-14105-00	9 - 15	1RC-15393-00	10 - 25	1RC-17211-00	17 - 32	BS2-2163A-00	21 - 33
1RC-11603-00	2 - 7	5VY-12277-00	26 - 14	5PS-14147-00	10 - 9	3P6-15399-00	45 - 11	2PP-17221-00	17 - 21	1RC-21650-00	23 - 19
1RC-11631-00	2 - 6		26 - 32	2C0-14216-00	9 - 9	1RC-15411-01	14 - 1	1RC-17231-00	17 - 29	BS2-21651-00	21 - 51
39P-11633-00	2 - 8	1RC-12405-01	6 - 2	5FL-14216-00	9 - 14	1RC-15416-00	14 - 29	1RC-17241-00	17 - 26	BM6-21668-00	21 - 59
1RC-11650-01	2 - 2	1RC-12410-00	5 - 21	8CC-14216-10	9 - 12	BS2-15418-00	13 - 25	1RC-17251-10	17 - 30	BS2-21681-00	21 - 25
1RC-11654-00	2 - 3	1RC-12420-00	5 - 1	3XV-14251-00	9 - 7	1RC-15421-11	14 - 16	2PP-17261-00	17 - 24	BS2-21711-00-33	22 - 33
1RC-11656-00	2 - 4	1RC-12422-00	5 - 3	8FP-14349-00	9 - 6	1RC-15441-00	13 - 22	1RC-17411-00	17 - 1	BS2-21711-00-P7	22 - 33
1RC-11656-10	2 - 4	5FC-12437-00	6 - 10	8FP-14349-20	9 - 5	BD5-15451-00	14 - 6	1RC-17421-00	17 - 16	BS2-2171E-00-33	6 - 31
1RC-11656-20	2 - 4	5VK-12438-00	5 - 7	8FP-14349-30	9 - 8	1RC-15456-00	14 - 30	5PS-17460-00	17 - 34	BS2-2171E-00-P6	6 - 31
1RC-11656-30	2 - 4	1RC-12439-00	5 - 11	1RC-14411-00	10 - 12	1RC-15461-00	14 - 20	1RC-18101-01	19 - 8	BS2-2171X-00-33	6 - 34
1RC-12111-01	3 - 1	1RC-1243A-00	6 - 20	1RC-14421-20	10 - 13	1RC-15484-00	14 - 13	1RC-18110-00	19 - 17	BS2-2171X-00-P6	6 - 34
1RC-12113-00	3 - 4	1RC-12450-00	5 - 2	1RC-14425-00	10 - 23	BS2-15490-00	14 - 24	1RC-18112-00	19 - 14	BS2-2171Y-00	22 - 38
1RC-12114-00	3 - 5	1RC-12459-00	5 - 4	1RC-14426-00	10 - 24	B90-15492-00	14 - 18	5EB-18113-00	19 - 18	BS2-21721-00-33	22 - 43
1RC-12116-00	3 - 3	2PP-12461-00	6 - 1	B90-1443J-00	9 - 21	1RC-15512-00	15 - 1	BS2-18115-00	19 - 19	BS2-21721-00-P7	22 - 43
3D7-12117-00	3 - 6	4FL-12462-00	6 - 9	B50-1444J-00	9 - 22	1RC-15515-00	15 - 5	5LV-18116-00	19 - 22	BS2-2172E-00	22 - 1
1WG-12118-00	3 - 7	1RC-12467-00	6 - 5	1RC-14451-00	10 - 14	5EB-15521-00	15 - 2	1D7-18127-00	19 - 4	1RC-2172W-00	6 - 44
4TE-12119-00	3 - 8	1RC-12469-00	5 - 23	1RC-14452-00	10 - 15	1RC-15590-00	15 - 3	1RC-18140-00	19 - 11	BS2-2172Y-00	22 - 48
1RC-12121-00	3 - 2	1AA-12535-00	6 - 4	1RC-14453-00	10 - 17	1RC-16150-00	16 - 1	4XV-18154-00	19 - 23	BS2-21731-00	22 - 34
4C8-12153-09	3 - 10	1RC-12564-00	14 - 7	1RC-14454-00	10 - 19	5VY-16154-00	16 - 2	2C0-18175-00	19 - 10	BS2-2173E-40	22 - 53
4C8-12153-10	3 - 10	1RC-12572-00	10 - 4	1RC-1445C-00	11 - 7	2C0-16164-00	16 - 27	1RC-18511-00	18 - 4	BS2-2173E-70	22 - 53
1HX-12168-F0	3 - 9	1RC-12576-00	5 - 35	1RC-14463-00	10 - 18	5VY-16164-00	16 - 26	1RC-18512-00	18 - 5	BS2-2173F-40	22 - 54
1HX-12168-H1	3 - 9	1RC-12577-00	5 - 18	B50-14465-00	9 - 19	B90-16173-00	16 - 9	1RC-18513-00	18 - 6	BS2-2173F-70	22 - 54
1HX-12168-K1	3 - 9	BS2-12578-00	5 - 26	4FM-14613-00	12 - 5	1TD-16178-00	16 - 16	1RC-18531-00	18 - 7	BS2-21741-00	22 - 44
1HX-12168-M1	3 - 9	BS2-12579-00	5 - 29	BS2-14708-00	12 - 3	1RC-16181-00	16 - 28	20S-18535-00	18 - 8	1RC-21747-00	22 - 15
1HX-12168-R1	3 - 9	1RC-12588-00	5 - 32	BS2-14710-00	12 - 1	5TA-16321-00	16 - 4	2C0-18536-00	18 - 9		22 - 32

NUMERICAL INDEX

PART NO.	REF. NO.	PART NO.	REF. NO.	PART NO.	REF. NO.	PART NO.	REF. NO.	PART NO.	REF. NO.	PART NO.	REF. NO.
1RC-21748-00	6 - 51	3XJ-23147-L0	26 - 36	1RC-24486-00	27 - 20	56P-25808-50	36 - 2	8CR-25924-00	32 - 15	BS2-2830C-00-P1	41 - 8
1RC-21749-00	6 - 47	26H-23156-00	26 - 5	1RC-24491-00	27 - 19	2DR-2580A-00	34 - 1	3GM-25925-00	30 - 13	BS2-2830C-00-P9	41 - 8
BS2-2174E-00	22 - 16		26 - 23	39P-24602-10	27 - 15	1RC-2580T-00	30 - 5		30 - 24	BS2-2830D-00-P1	41 - 9
BS2-2175T-00	6 - 23	509-23158-L0	26 - 11	1RC-2465B-00	21 - 52	2DR-2580U-00	30 - 16	1RC-25926-00	32 - 17	BS2-2830D-00-P9	41 - 9
BS2-2175U-00	6 - 27		26 - 29	BS2-24730-00	28 - 1	2DR-2580W-00	32 - 5	5VS-25975-00	30 - 27	BS2-2831V-00	41 - 11
BS2-2177E-00	21 - 57	BS2-23170-00	26 - 28	B90-24780-00	28 - 5	2DR-2581J-00	36 - 24	1RC-26111-00	33 - 1	BS2-2832V-00	41 - 13
1RC-21816-00	6 - 43	BS2-23170-10	26 - 10	1RC-2478X-00	28 - 7	2DR-2581K-00	36 - 21	B90-2612E-00	34 - 24	2S3-28347-00	27 - 26
1RC-21826-00	6 - 40	4FM-23171-40	26 - 9	1RC-24847-12	25 - 13	1RC-2581T-00	30 - 1	1RC-26132-00	6 - 17	5PS-28372-00	21 - 8
1RC-21828-00	6 - 39		26 - 27	1RC-24848-12	25 - 14	1J3-2582A-00	30 - 14	23P-26133-00	33 - 13	BS2-2837N-00	22 - 8
1RC-21871-00	6 - 37	278-23181-50	26 - 12	2PP-25117-00	29 - 2	5VS-25824-00	30 - 25		33 - 15	BS2-2837R-00	22 - 25
1RC-21875-00	6 - 38		26 - 30	2DR-25168-00-P0	29 - 1	8CR-25824-00	32 - 18	2DR-26199-00	21 - 6	BS2-2838D-00	41 - 5
B90-22110-01	23 - 1	1RC-23340-11	26 - 38	2DR-25168-00-P3	29 - 1	306-25825-01	30 - 15	4YR-26240-02	33 - 3	BS2-283D3-00	21 - 48
20S-22128-00	23 - 6	3LC-23357-00	26 - 16	2DR-2517G-00	30 - 3		30 - 26	4YR-26241-02	33 - 2	BS2-283D4-00	21 - 49
46X-22141-00	23 - 46		26 - 34		32 - 3	1UY-25825-51	32 - 19	5GJ-26246-00	33 - 4	682-44532-00	21 - 17
1RC-22151-00	23 - 12	1RC-23377-00	25 - 21	1RC-25181-00	29 - 9	5SL-25827-00	32 - 20	39P-2627E-00	33 - 16	1RC-81410-00	37 - 2
1RC-22159-00	23 - 47	BS2-23389-20	25 - 18	2PP-25317-00	31 - 7	5SL-25827-10	32 - 21	1RC-26280-00	33 - 12	1RC-81450-00	37 - 1
1RC-2217A-00	23 - 31	BS2-23391-00	41 - 20	2DR-25338-00-P0	31 - 3	5SL-25828-01	32 - 22	4KG-26281-00	33 - 6	1RC-81815-00	38 - 9
1RC-2217M-00	23 - 43	1RC-23393-00	25 - 7	2DR-25338-00-P6	31 - 3	2D1-2582A-00	36 - 3	3XW-26282-01	33 - 7	28P-81826-00	38 - 2
30X-2219X-00	23 - 4	BS2-23397-00	41 - 23	1RC-25364-00	31 - 8	1RC-2582E-00	36 - 28	1RC-26290-00	33 - 14	4XV-8182A-00	38 - 6
BS2-2219X-00	23 - 52	5VX-23415-00	25 - 2	5JJ-25366-00	31 - 12	1RC-2582W-00	32 - 1	1RC-26302-00	33 - 5		38 - 10
1RC-22210-01	24 - 1	26H-23418-01	25 - 5	BS2-2537W-00	31 - 19	5SL-25838-00	32 - 9	2C0-26326-00	36 - 12	4B5-81840-00	38 - 4
1RC-2221A-00	23 - 23	1RC-23435-30	25 - 8	BS2-25381-00	31 - 31	56P-2583V-00	36 - 1	5VS-26332-00	34 - 10	11H-81844-00	38 - 8
1RC-2221B-00	23 - 24	1RC-23441-11	25 - 10	1RC-25383-00	31 - 14	B6C-2584A-00	34 - 21	1RC-26335-01	33 - 9	1FK-81847-00	38 - 7
BS2-22311-00	23 - 14	3GB-23448-00	23 - 34	1RC-25389-00	31 - 22	2DR-2584B-00	34 - 22	4GL-27114-00	28 - 2	3TB-81847-00	38 - 3
1RC-22358-00	23 - 30	1RC-2344A-11	25 - 11	BS2-25389-00	31 - 23	2C0-25852-00	36 - 8	5UY-27114-00	28 - 4		38 - 5
1RC-22825-00	6 - 42	3FV-23462-00	26 - 39	5MT-25398-00	29 - 7	5VS-25852-00	34 - 3	1RC-27200-00	35 - 27	1RC-81890-00	38 - 1
BS2-23102-00	26 - 19	BS2-23591-00	25 - 15		31 - 11	20S-25854-00	34 - 5	4BP-27222-02	36 - 5	1RC-81940-00	44 - 7
BS2-23103-00	26 - 1	BS2-23857-00	33 - 10	5MT-25398-10	29 - 7	2VN-25854-00	36 - 9	1RC-27311-00	35 - 1	1ST-81950-00	44 - 28
BS2-23110-00	26 - 21	1RC-24104-00	27 - 8		31 - 11	2VN-25855-00	36 - 10	1RC-27321-00	35 - 2	5VK-81950-40	44 - 27
BS2-23111-00	26 - 35	23P-24104-01	27 - 2	5MT-25398-20	29 - 7	5VS-25855-00	34 - 4	1RC-27410-00	35 - 15	5JJ-81952-00	44 - 29
BS2-23111-10	26 - 17	1RC-24106-01	27 - 27		31 - 11	4BP-2585F-01	36 - 4	1RC-2741L-01	35 - 44	1D7-81960-01	44 - 25
1RC-23118-00	26 - 15	1RC-24108-01	27 - 28	BS2-25445-00	31 - 16	5VS-25867-00	34 - 11	BS2-27425-00	23 - 22	5VY-82100-00	44 - 5
	26 - 33	1RC-2413B-01	27 - 48	BS2-25715-00	31 - 24	2DR-25872-00	34 - 16	1RC-2742L-01	35 - 51	5SL-82113-01	45 - 17
BS2-23120-00	26 - 3	1RC-2413Y-00	27 - 13	BS2-25716-00	31 - 27	5SL-25876-00	25 - 19	3VR-27431-02	35 - 43	BS2-82116-00	44 - 1
4KM-23123-01	26 - 42	BS2-24141-00	27 - 36	4SV-25802-00	30 - 8	14B-25894-00	36 - 7	1RC-27432-00	35 - 34	5SL-82119-30	44 - 9
1RC-23125-00	26 - 8	2PP-2414J-00	27 - 35		30 - 19	1RC-25895-00	36 - 13	5VX-27437-00	35 - 47	BS2-8212B-00	21 - 5
	26 - 26	2CR-24170-00	27 - 37	5SL-25802-00	32 - 6	5VS-2589F-00	34 - 7		35 - 54	1RC-82137-00	21 - 12
1RC-23126-40	26 - 2	B90-24183-00	27 - 38	4SV-25802-10	30 - 6	5VS-2589H-00	34 - 6	3VR-27441-02	35 - 50	42X-82151-00	44 - 8
	26 - 20	1RC-2418B-01	27 - 24		30 - 17	5SL-25914-00	32 - 11	1RC-27442-00	35 - 17	5JJ-82151-00	44 - 12
1RC-23141-00	26 - 13	1RC-2419B-01	27 - 25	5SL-25803-00	32 - 7	5DH-25916-00	32 - 16	BS2-27443-00	35 - 26	5JJ-82151-10	44 - 13
	26 - 31	B90-2419F-00	27 - 39	3GM-25803-10	30 - 7	3JD-25917-00	32 - 13	3XV-27461-02	35 - 21	5JW-82151-10	44 - 14
4EB-23144-00	26 - 4	1RC-241B1-00	27 - 30		30 - 18	5SL-25917-00	32 - 8	1RC-274A3-00	35 - 12	5JJ-82151-30	44 - 15
	26 - 22	B90-24313-00	27 - 41	3MA-25803-10	30 - 9	13S-25919-00	30 - 11	1RC-28100-00	28 - 11	5JJ-82151-60	44 - 17
4EB-23145-01	26 - 6	1RC-24315-00	27 - 22		30 - 20		30 - 22	1RC-28135-00	28 - 12	5JJ-82151-80	44 - 16
	26 - 24	60L-24321-00	9 - 20	5SL-25805-00	30 - 10	5SL-25919-00	32 - 10	2H7-28151-00	28 - 13	5JJ-82151-90	44 - 18
36Y-23146-10	26 - 7	BS2-24321-00	27 - 44		30 - 21	2DR-25921-50	32 - 12	2GV-28152-00	28 - 14	34D-82176-00	20 - 14
	26 - 25	3D7-24339-00	27 - 9	5VX-25806-00	32 - 14	4SV-25924-00	30 - 12	23P-28164-00	28 - 15	1RC-82309-01	44 - 3
3XJ-23147-L0	26 - 18	68V-24376-00	9 - 3	1MC-25807-00	34 - 2		30 - 23	4KG-28186-10	28 - 16	1RC-82310-00	45 - 3

NUMERICAL INDEX

PART NO.	REF. NO.	PART NO.	REF. NO.	PART NO.	REF. NO.	PART NO.	REF. NO.	PART NO.	REF. NO.	PART NO.	REF. NO.
BS2-82318-00	44 - 21	BS2-83969-00	43 - 12	90105-10188	35 - 3	90110-06394	14 - 12	90160-05013	10 - 16	90201-10035	23 - 39
1WS-82380-00	9 - 10	1HP-83980-01	34 - 12	90105-10210	23 - 41	90110-06395	4 - 10	90160-05017	40 - 2		35 - 10
BS2-82470-00	19 - 24	BS2-84300-00	41 - 1		23 - 44	90110-06396	5 - 13	90167-05079	21 - 56	90201-10075	20 - 7
1RC-82509-00	44 - 4	BS2-8431R-00	41 - 25	90105-10252	35 - 42		14 - 31	90167-05080	41 - 4	90201-101J1	24 - 4
5SL-82511-08	45 - 18	BS2-84527-00	41 - 27	90105-10377	35 - 20	90110-08096	35 - 57		41 - 10	90201-12008	2 - 12
4D3-8252R-00	44 - 6	32D-84553-00	21 - 9	90105-10391	20 - 9	90110-10043	20 - 6	90170-06228	19 - 20	90201-12541	5 - 14
B90-82530-00	35 - 31	BS2-84700-00	42 - 1	90105-10437	20 - 10	90111-05002	6 - 32	90170-08010	36 - 6	90201-12575	19 - 7
1RC-82540-00	45 - 4	BS2-84745-00	21 - 24	90105-10440	30 - 28		6 - 35	90176-06009	40 - 7	90201-127E1	19 - 3
BAE-8255P-00	45 - 16	BS2-84751-00	21 - 35	90105-126A8	2 - 11		22 - 13	90176-06016	21 - 45	90201-13015	23 - 38
1RC-82566-50	35 - 7	5SL-84753-00	27 - 33	90109-06037	22 - 40		22 - 30	90179-05523	6 - 46	90201-17018	35 - 11
5PS-82576-01	44 - 30	4AG-85111-00	21 - 39		22 - 50		22 - 35	90179-06074	41 - 14	90201-177G4	19 - 12
1RC-82589-00	44 - 36	3Y6-85130-02	21 - 22	90109-06100	13 - 16		22 - 45	90179-06520	22 - 9	90201-18021	31 - 33
2D1-82589-00	44 - 39	2DR-85132-00	34 - 23	90109-061F7	1 - 8		41 - 24		22 - 26	90201-20008	17 - 37
BS2-82590-00	44 - 11	BS2-85132-00	46 - 9	90109-06202	21 - 10	90111-05036	35 - 8	90179-08410	12 - 6	90201-20030	16 - 17
1RC-82599-00	44 - 19	2DR-85142-00	36 - 22	90109-06271	1 - 29	90111-06061	21 - 21	90179-10024	20 - 11	90201-22018	25 - 6
1B3-82911-00	43 - 1	2DR-85542-00	46 - 4	90109-06293	1 - 10	90111-06127	41 - 21	90179-20011	16 - 19	90202-05180	6 - 33
3YX-82917-01	43 - 8	BS2-85542-00	46 - 18	90109-06317	41 - 16	90111-06130	13 - 28	90179-22018	17 - 36		6 - 36
BS2-83310-00	39 - 1	5S7-85720-00	45 - 7	90109-064G6	30 - 2	90111-06136	27 - 11	90179-25004	25 - 3		22 - 14
1KB-83311-00	39 - 2	1MC-85884-00	9 - 13	90109-066F0	1 - 27	90111-06146	22 - 10	90183-05042	41 - 2		22 - 31
	39 - 6	13S-85885-00	9 - 11	90109-08045	32 - 2		22 - 27		41 - 6		41 - 12
	39 - 13	5YU-85886-00	44 - 2	90109-08170	12 - 10	90111-06161	23 - 21		42 - 3	90202-07164	23 - 29
	39 - 17	BS2-8591A-00	45 - 15	90109-08196	45 - 19	90111-06169	12 - 4	90183-05076	6 - 26	90202-26142	25 - 4
BS2-83318-00	21 - 43	59C-8592A-00	12 - 2	90109-08231	35 - 16	90111-08005	35 - 29		6 - 30	90206-17084	35 - 19
3D7-83318-10	39 - 9	B50-85930-09	46 - 1		35 - 25	90111-08038	36 - 15		22 - 36	90208-20001	16 - 18
	39 - 20	BS2-85970-00	46 - 17	90109-10027	23 - 36	90111-10039	35 - 18		22 - 46	90208-22002	17 - 35
BS2-83320-00	39 - 5	2DR-85980-01	46 - 21	90110-05028	27 - 21	90116-08087	1 - 17		41 - 22	90209-21332	17 - 6
BS2-83330-00	39 - 12	2DR-85991-00	46 - 3	90110-05067	45 - 6	90116-10048	31 - 17		42 - 2	90209-21351	17 - 12
1KB-8333A-00	39 - 3	5VY-8A8E0-00	45 - 8	90110-05112	27 - 16	90119-06051	27 - 7	90183-05M02	22 - 37	90209-22352	17 - 11
	39 - 18	3D9-H3333-10	39 - 4	90110-06108	13 - 23	90119-06137	6 - 25		22 - 39	90209-28008	17 - 22
BS2-83340-00	39 - 16		39 - 8	90110-06161	45 - 13		6 - 29		22 - 47	90214-28002	17 - 28
1KB-8334A-00	39 - 7		39 - 15	90110-06164	8 - 12	90119-06267	22 - 3		22 - 49	90214-29002	17 - 27
	39 - 14		39 - 19	90110-06168	14 - 14		22 - 20		31 - 28	90240-08005	36 - 16
4GY-83350-00	45 - 22	1RC-W2470-00	28 - 9	90110-06169	8 - 8	90119-06M55	46 - 13	90183-06069	21 - 7	90249-03002	21 - 53
BS2-8336T-00	22 - 11	BAE-W8250-00	45 - 14	90110-06173	7 - 10	90119-09010	13 - 8	90183-061A4	41 - 15	90269-06001	22 - 7
BS2-8336U-00	22 - 28	1RC-Y2410-00-X4	27 - 1	90110-06175	1 - 22	90119-09013	13 - 7	90185-08089	35 - 28		22 - 24
BS2-83371-00	45 - 20	1RC-Y2410-00-X7	27 - 1	90110-06200	21 - 3	90119-09017	1 - 7	90185-18009	31 - 32	90269-06008	21 - 34
BS2-83500-00	40 - 1	90101-08013	23 - 26	90110-06223	37 - 3	90149-05029	30 - 4	90201-04030	44 - 32		22 - 6
4XV-83513-00	40 - 4	90101-10042	24 - 2	90110-06233	6 - 50		32 - 4	90201-05036	40 - 3		22 - 23
BS2-83519-00	40 - 8	90105-06027	1 - 3		10 - 27	90149-05037	1 - 25	90201-06033	6 - 19	90269-07007	21 - 11
BS2-83559-00	40 - 5	90105-06066	7 - 4	90110-06274	5 - 25	90149-06082	17 - 15	90201-06063	41 - 17		21 - 58
4P9-83591-00	45 - 2	90105-06080	6 - 7	90110-06321	14 - 23	90149-06104	23 - 53	90201-06072	27 - 5		22 - 42
5EB-83912-03	43 - 2	90105-06126	23 - 25	90110-06388	5 - 16	90149-06158	14 - 19	90201-06557	21 - 37		22 - 52
5JJ-83913-00	43 - 11	90105-06169	21 - 44		10 - 11		18 - 11	90201-08048	35 - 41		23 - 13
5VS-83922-00	34 - 9	90105-06192	34 - 25		14 - 10	90149-06298	25 - 16	90201-08066	36 - 17		23 - 18
4XV-83929-00	43 - 7		36 - 23		14 - 22	90149-08030	15 - 4	90201-08103	35 - 30		23 - 55
2C0-83945-00	43 - 3	90105-06202	13 - 14		38 - 11	90149-10060	20 - 3	90201-087G2	12 - 9	90269-07015	44 - 38
5LV-83951-00	43 - 6	90105-07006	4 - 4	90110-06389	14 - 11	90159-05035	21 - 27	90201-087P8	46 - 11	90269-07077	27 - 32
BS2-83963-10	43 - 14	90105-10174	23 - 50	90110-06394	5 - 15	90159-06150	35 - 39	90201-10029	16 - 24	90280-05029	2 - 10



NUMERICAL INDEX

PART NO.	REF. NO.	PART NO.	REF. NO.	PART NO.	REF. NO.	PART NO.	REF. NO.	PART NO.	REF. NO.	PART NO.	REF. NO.
90338-06018	22 - 2	90387-21003	17 - 9	90464-30011	21 - 42	90501-06022	18 - 2	92017-06020	27 - 14	93399-99932	26 - 40
	22 - 19	90387-25008	17 - 31	90464-45007	44 - 24	90501-12743	35 - 45	92017-08012	14 - 4	93430-02001	21 - 55
90338-07157	6 - 6	90387-25030	17 - 4	90465-06025	8 - 9		35 - 52	92902-04100	34 - 14	93440-25186	17 - 7
	28 - 3	90387-28004	17 - 25	90465-08053	45 - 10	90506-18021	19 - 1	92902-04600	34 - 15	93440-31187	17 - 23
90338-16262	13 - 5	90387-30012	17 - 18	90465-10098	44 - 22	90506-20032	35 - 5	92907-05600	6 - 12	93440-64199	17 - 19
90340-14011	13 - 20	90387-31003	17 - 20	90465-10075	6 - 41	90506-23008	35 - 33	92907-08600	16 - 33	93450-18157	2 - 9
90340-14132	8 - 4	90401-10042	34 - 18		6 - 49	90508-09007	21 - 54	93101-12173	5 - 6	93501-04011	35 - 46
90340-18002	1 - 4	90401-10172	34 - 17	90467-09006	9 - 23	90508-18051	16 - 23	93102-12106	19 - 5		35 - 53
90340-36005	14 - 2		36 - 25		27 - 23	90508-20572	35 - 24	93102-15212	16 - 29	93603-16219	5 - 8
90380-16134	23 - 2	90401-20011	8 - 1		27 - 42	90508-32141	19 - 9	93102-25017	29 - 4	93607-44002	4 - 13
90387-05003	21 - 28	90413-06031	9 - 16	90467-09026	27 - 43	90520-02005	36 - 29	93102-28022	31 - 5	93610-20189	14 - 21
90387-05028	36 - 11	90430-06014	5 - 12	90467-09103	9 - 18	90520-10003	22 - 18	93102-40030	17 - 33	93900-00030	29 - 6
90387-06022	23 - 20	90430-08143	14 - 5	90467-10039	6 - 21	90520-10022	22 - 17	93106-22002	23 - 10		31 - 10
90387-06057	22 - 5	90430-10004	45 - 1		6 - 22	90520-15012	27 - 31	93106-40013	31 - 15	94112-17126	29 - 5
	22 - 22	90430-10005	34 - 19	90467-10041	27 - 45	91312-04020	44 - 31	93108-35004	23 - 5	94112-17127	29 - 5
90387-06066	23 - 16		36 - 26	90467-100A1	9 - 17	91312-05010	27 - 17	93109-17071	23 - 9	94118-17077	31 - 9
90387-060U2	31 - 26	90445-197J2	35 - 6	90467-120A3	36 - 14	91312-06020	19 - 15		23 - 33	94118-17078	31 - 9
90387-06136	27 - 10	90450-32003	5 - 33	90467-14015	10 - 28	91312-06025	8 - 7	93210-04092	13 - 3	94581-79066	7 - 11
	41 - 18		5 - 36	90467-15001	10 - 26	91312-06030	6 - 18	93210-07540	13 - 10	94582-31110	31 - 1
90387-06153	21 - 2	90450-38040	5 - 19	90467-17003	11 - 8	91312-06035	7 - 5	93210-12790	13 - 6	94591-57128	4 - 5
90387-06158	6 - 16		5 - 34	90467-17089	11 - 3		25 - 9	93210-14369	13 - 21	94682-31031	31 - 2
90387-06160	46 - 7	90450-53007	10 - 20		11 - 5		25 - 12	93210-15566	45 - 12	94701-00431	1 - 9
90387-06170	6 - 24	90450-56009	10 - 2	90467-200A0	5 - 28		26 - 41	93210-16325	13 - 19	95022-06008	44 - 10
	6 - 28	90464-05003	39 - 10		5 - 31	91314-08035	26 - 37	93210-19123	14 - 28	95022-06014	28 - 10
90387-06205	10 - 21	90464-05188	46 - 20	90467-21068	5 - 27	91317-05035	33 - 8	93210-21001	45 - 5	95022-06016	28 - 8
90387-06207	23 - 54	90464-07M40	6 - 53	90467-22002	5 - 30	91401-20012	36 - 18	93210-22001	7 - 7		45 - 9
	31 - 30	90464-09M31	27 - 46	90467-310A0	5 - 20	91401-25015	35 - 49	93210-28543	14 - 8	95022-06025	44 - 26
90387-06260	21 - 46	90464-10233	46 - 16		5 - 37		35 - 56	93210-30694	5 - 17		46 - 10
90387-06266	27 - 4	90464-12013	46 - 14	90480-01558	27 - 34	91402-25015	35 - 23	93210-357A3	14 - 3	95027-06010	40 - 9
90387-06285	6 - 45	90464-13073	43 - 17	90480-01559	22 - 41	91701-08040	35 - 22	93210-46044	5 - 24	95027-06020	43 - 5
90387-06286	13 - 26		44 - 33		22 - 51	91702-08040	35 - 48	93210-61750	5 - 10	95304-06700	19 - 21
90387-06288	21 - 14	90464-13227	19 - 26	90480-11009	21 - 26		35 - 55	93306-00106	5 - 5	95602-05200	21 - 23
90387-062X0	23 - 15		39 - 11	90480-12012	23 - 11	91808-16023	1 - 5	93306-00416	31 - 6	95602-06200	21 - 38
90387-06322	19 - 28	90464-14003	46 - 15	90480-12314	10 - 22	92012-05030	6 - 52	93306-20352	29 - 3	95602-10100	24 - 3
90387-06372	21 - 20	90464-14010	19 - 27	90480-12607	35 - 37	92012-06010	46 - 2	93306-20464	17 - 14	95602-10200	23 - 42
90387-06M16	35 - 38		44 - 34	90480-13010	7 - 8		46 - 5		17 - 38		23 - 45
90387-07015	40 - 6		44 - 37	90480-13018	13 - 27	92012-06012	27 - 40	93306-20480	31 - 4		23 - 51
90387-07717	6 - 8	90464-14013	34 - 26	90480-13203	6 - 48	92012-06020	19 - 29	93306-205B5	31 - 13		25 - 17
90387-08021	12 - 8	90464-15157	35 - 36	90480-13398	41 - 3		21 - 15	93306-20663	17 - 17		31 - 18
90387-08102	35 - 40		44 - 20		41 - 7		46 - 8	93306-30534	17 - 3	95602-14200	23 - 48
90387-10050	35 - 9	90464-16061	21 - 41	90480-13567	46 - 6	92012-06030	35 - 14	93310-33277	16 - 20	95607-06200	43 - 4
90387-10106	23 - 49		44 - 23	90480-14003	21 - 47	92012-06035	27 - 6	93315-21570	16 - 30	95612-10100	23 - 37
90387-102R4	23 - 7	90464-18002	23 - 28		22 - 4	92012-06040	35 - 13	93315-31758	23 - 8		35 - 4
	23 - 40		34 - 20		22 - 21	92014-06014	46 - 22		23 - 32	95617-06100	34 - 8
90387-127W0	23 - 35	90464-18007	36 - 20	90480-14052	21 - 13	92017-06010	33 - 11	93317-11096	16 - 32	95702-06500	21 - 40
90387-17017	29 - 8	90464-20022	44 - 35	90480-14102	41 - 19		45 - 21	93317-11295	19 - 16		28 - 6
90387-20035	31 - 21	90464-20023	36 - 19	90480-15363	6 - 15	92017-06012	25 - 20	93317-22262	23 - 3	95702-08500	23 - 27
90387-20036	31 - 20	90464-30011	19 - 25	90480-18008	27 - 3	92017-06016	46 - 19	93399-99931	25 - 1	95707-05500	36 - 27

NUMERICAL INDEX

PART NO.	REF. NO.	PART NO.	REF. NO.	PART NO.	REF. NO.	PART NO.	REF. NO.	PART NO.	REF. NO.	PART NO.	REF. NO.
95812-06014	21 - 32										
95812-06040	13 - 11										
95812-06050	13 - 12										
95812-06065	13 - 13										
95812-08060	13 - 15										
95817-08025	21 - 30										
95822-06025	5 - 22										
95827-06020	46 - 12										
95D02-06010	35 - 35										
95D07-06016	41 - 26										
95D32-06012	6 - 14										
95D32-06025	27 - 12										
95D37-06014	31 - 25										
	31 - 29										
97002-06016	23 - 17										
97007-05012	6 - 11										
97707-40012	21 - 50										
98502-04012	34 - 13										
98507-04010	43 - 10										
98507-04020	43 - 15										
98507-04025	43 - 13										
98507-04030	43 - 16										
98507-06020	21 - 36										
98704-03020	43 - 9										
99001-07600	16 - 34										
99002-10600	19 - 6										
99009-10400	16 - 25										
99009-12400	5 - 9										
99009-15500	7 - 3										
99009-17400	19 - 13										
99244-00080	21 - 60										
99247-00080	21 - 60										
99530-08012	14 - 9										
99530-10014	13 - 4										
99530-12016	1 - 31										