



PARTS CATALOGUE

2019



GREY



BLUE

MTN690-A (B7S2) MALAYSIA *MT07*



1UB7S-440E5

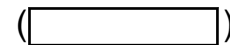

MTN690-A
PARTS CATALOGUE
©2018 by Yamaha Motor Co., Ltd.
1st edition, November 2018
All rights reserved.
Any reprinting or unauthorized use
without the written permission of
Yamaha Motor Co., Ltd.
is expressly prohibited.
Printed in Japan.

FOREWORD

This Parts Catalogue is related to the parts for the model(s) on the cover page. When you are ordering replacement parts, please refer to this Parts Catalogue and quote both part numbers and part names correctly.

1. Modifications or additions which have been made after the issue of the Parts Catalogue will be announced in the Parts News.
It is advisable that you make the necessary corrections to the Parts Catalogue according to the Parts News.
2. Abbreviations
The following abbreviations are used in this Parts Catalogue.
“UR” Use specified parts number.
“UN” Use as many as needed.
“AP” Alternate Parts
“LM” Locally Made (Parts need to be ordered locally)
“F#” Frame No. (Applicable machine No.)
“O/S” Over Size
3. The number of components for assembly
 - Parts, which are to be supplied in an assembly, are listed with a dot (.) in front of the part name as shown below.
 - The numeral appearing to the right of each component part indicates the quantity of parts for each assembly unit.

PART NO.	DESCRIPTION	Q'TY	REMARKS
2F5-83310-60	FRONT FLASHER LIGHT ASSY	2	
115-83311-60	.BULB (6V-18W)	1	

4. Applicable colours of graphics are represented in the “REMARKS” as shown below.

PART NO.	DESCRIPTION	Q'TY	REMARKS
2N4-24110-00-X5	FUEL TANK COMP.	2	MXR
3J1-24240-10	.GRAPHIC, FUEL TANK	1	FOR MXR

5. Note that the illustrations for reference in finding parts numbers are not to be used for assembling. When assembling, please use the applicable service manual.

6. The asterisk (*) before a reference number indicates modified items after the first edition.

FOREWORD

7. Applicable Serial No.

Frame Serial No.

Engine Serial No.

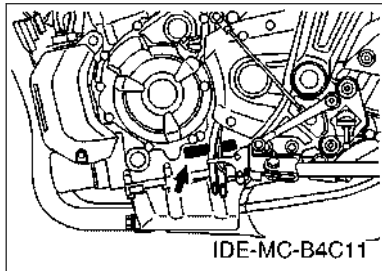
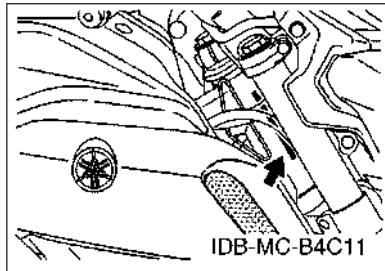

8. Applicable Colour Code (The (*) mark shows Model colour.)

Abbreviation	Colour Name	Colour Code
DPBM15	DEEP PURPLISH BLUE METALLIC 15	1329
DPBMC(*)	DEEP PURPLISH BLUE METALLIC C	0564
MBL2	MAT BLACK 2	0582
MLNM4(*)	MAT LIGHT GRAY METALLIC 4	1700
VYRS6	VIVID YELLOWISH RED SOLID 6	1699
YB	YAMAHA BLACK	0033

9. Applicable Starting Serial No.

Frame Serial No.

Serial No.	Name Of Q'ty Column	Model Code

Engine Serial No.

Serial No.	Name Of Q'ty Column	Model Code

CONTENTS

ENGINE

CYLINDER HEAD.....	1
CRANKSHAFT & PISTON.....	2
VALVE.....	4
CAMSHAFT & CHAIN.....	6
WATER PUMP.....	7
RADIATOR & HOSE.....	9
OIL PUMP.....	11
OIL CLEANER.....	12
INTAKE.....	13
INTAKE 2.....	14
EXHAUST.....	15
CRANKCASE.....	16
CRANKCASE COVER 1.....	17
STARTER.....	18
CLUTCH.....	19
TRANSMISSION.....	20
SHIFT CAM & FORK.....	22
SHIFT SHAFT.....	23

CHASSIS

FRAME.....	24
FENDER.....	26
SIDE COVER.....	27
REAR ARM.....	29
REAR SUSPENSION.....	31
STEERING.....	32
FRONT FORK.....	33
FUEL TANK.....	35
FUEL TANK 2.....	37
SEAT.....	39
FRONT WHEEL.....	41
FRONT BRAKE CALIPER.....	42
REAR WHEEL.....	44
REAR BRAKE CALIPER.....	46
STEERING HANDLE & CABLE.....	47
FRONT MASTER CYLINDER.....	48
STAND & FOOTREST.....	50
STAND & FOOTREST 2.....	53
REAR MASTER CYLINDER.....	55

GENERATOR.....	57
STARTING MOTOR.....	58
FLASHER LIGHT.....	59
METER.....	60
HEADLIGHT.....	61
TAILLIGHT.....	62
HANDLE SWITCH & LEVER.....	63
ELECTRICAL 1.....	64
ELECTRICAL 2.....	66
ELECTRICAL 3.....	68

INDEX

NUMERICAL INDEX.....	69
----------------------	----

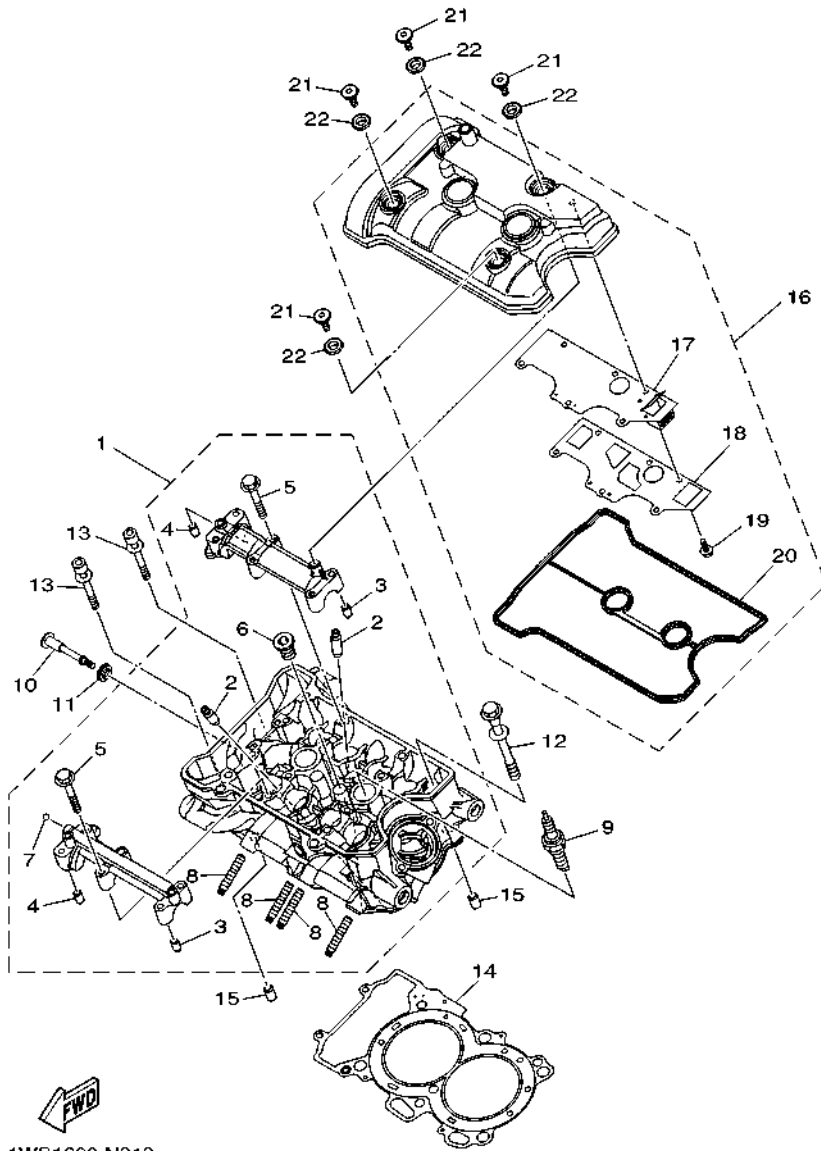

1WS1300-N010

FIG. 1 CYLINDER HEAD

REF. NO.	PART NO.	DESCRIPTION	B7S2				REMARKS
1	1WS-11101-09	CYLINDER HEAD ASSY	1				
2	4D9-11133-10	.GUIDE, VALVE 1	8				
3	91808-16023	.PIN, DOWEL	2				
4	91808-16023	.PIN, DOWEL	2				
5	90105-06027	.BOLT, FLANGE	12				
6	90340-18002	.PLUG, STRAIGHT SCREW	1				
7	93501-04011	.BALL	1				
8	90116-08087	.BOLT, STUD	4				
9	94701-00436	PLUG, SPARK (NGK LMAR8A-9)	2				
10	90109-06293	BOLT	1				
11	5VY-1111G-00	RUBBER, MOUNT 1	1				
12	90119-10056	BOLT, WITH WASHER	6				
13	90110-06081	BOLT, HEXAGON SOCKET HEAD	2				
14	1WS-11181-00	GASKET, CYLINDER HEAD 1	1				
15	99530-10114	PIN, DOWEL	2				
16	1WS-11190-01	COVER, CYLINDER HEAD 1	1				
17	1WS-11165-01	.PLATE, BREATHER	1				
18	1WS-11169-00	.GASKET, BREATHER COVER	1				
19	90105-05024	.BOLT, FLANGE	6				
20	1WS-11193-01	.GASKET, HEAD COVER 1	1				
21	90109-066F0	BOLT	4				
22	5VY-1111G-00	RUBBER, MOUNT 1	4				

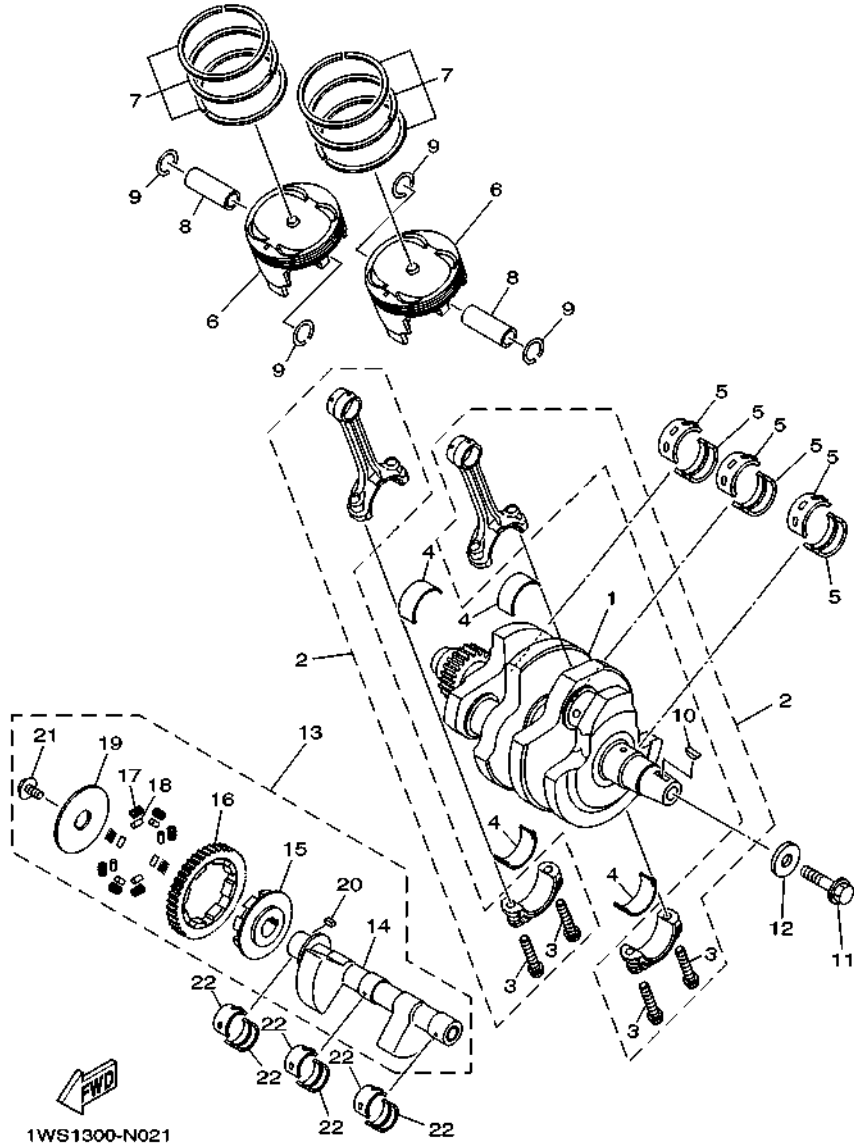

FIG. 2 CRANKSHAFT & PISTON

REF. NO.	PART NO.	DESCRIPTION	B7S2			REMARKS
1	1WS-11400-00	CRANKSHAFT ASSY	1			
2	1WS-11650-00	CONNECTING ROD ASSY	2			
3	1RC-11654-00	.BOLT, CONNECTING ROD	2			
4	1RC-11656-00	PLANE BEARING, CONNECTING ROD	4			UR BLUE
	1RC-11656-10	PLANE BEARING, CONNECTING ROD	4			UR BLACK
	1RC-11656-20	PLANE BEARING, CONNECTING ROD	4			UR BROWN
	1RC-11656-30	PLANE BEARING, CONNECTING ROD	4			UR GREEN
5	3GM-11416-B0	PLANE BEARING, CRANKSHAFT 1	6			UR PURPLE
	3GM-11416-A0	PLANE BEARING, CRANKSHAFT 1	6			UR WHITE
	3GM-11416-00	PLANE BEARING, CRANKSHAFT 1	6			UR BLUE
	3GM-11416-10	PLANE BEARING, CRANKSHAFT 1	6			UR BLACK
	3GM-11416-20	PLANE BEARING, CRANKSHAFT 1	6			UR BROWN
6	1WS-11631-00	PISTON (STD)	2			
7	1WS-11603-00	PISTON RING SET (STD)	2			
8	1WS-11633-00	PIN, PISTON	2			
9	93450-19052	CIRCLIP	4			
10	90280-05029	KEY, WOODRUFF	1			
11	90105-126A8	BOLT, FLANGE	1			
12	90201-12008	WASHER, PLATE	1			
13	1WS-11500-00	BALANCER ASSY	1			
14	1WS-11454-00	.WEIGHT 1	1			
15	1WS-11496-00	.BOSS, BUFFER	1			
16	1WS-11531-00	.GEAR, BALANCE WEIGHT	1			
17	90501-22721	.SPRING, COMPRESSION	8			
18	93605-10090	.PIN, DOWEL	8			
19	1WS-11533-00	.PLATE, ABSORBER	1			
20	90282-04001	.KEY, STRAIGHT	1			

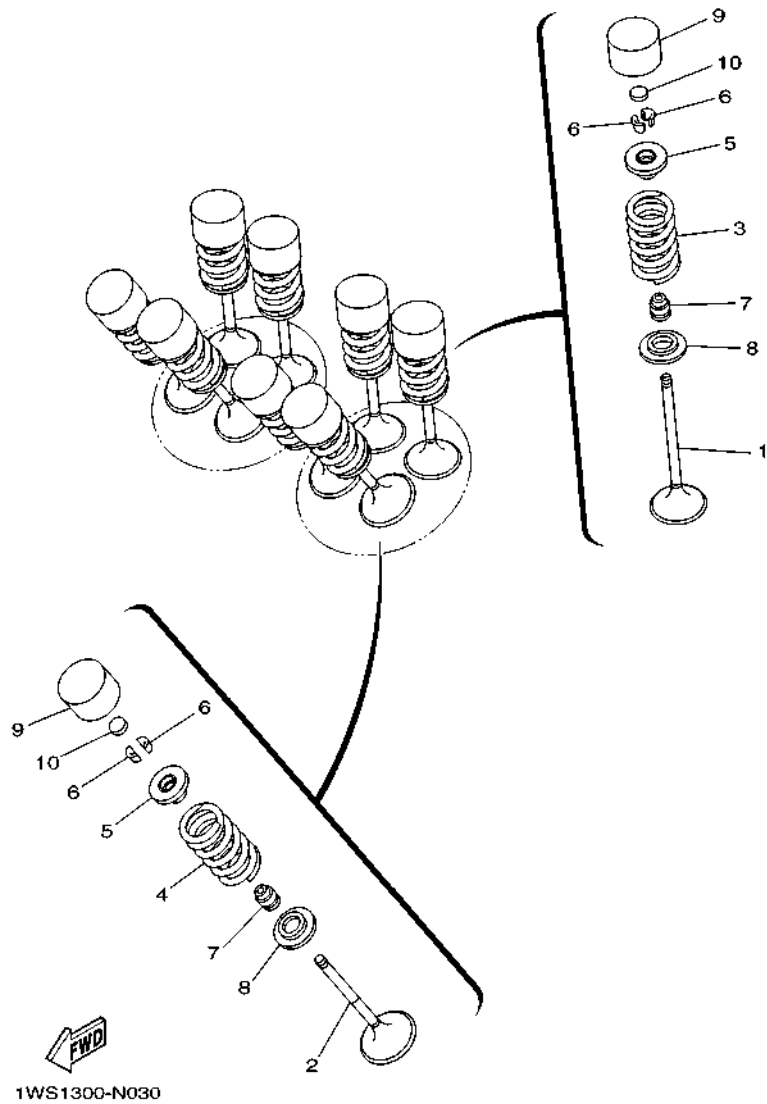
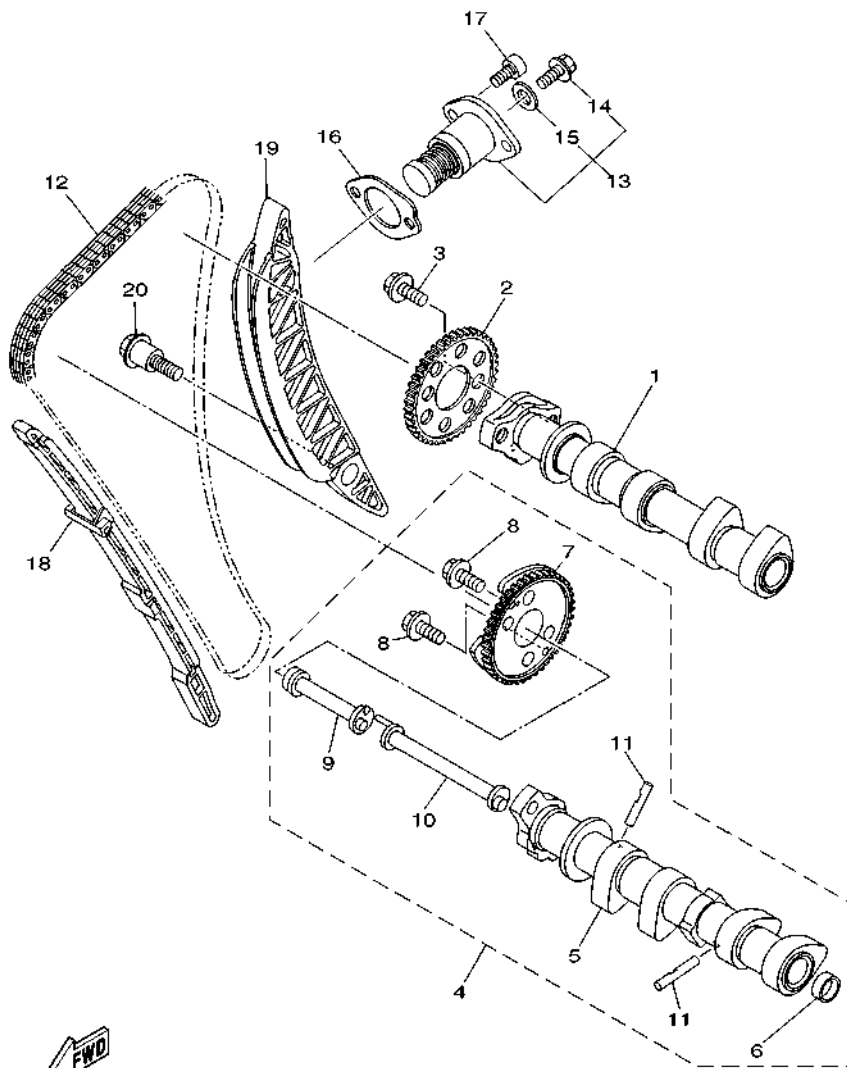

FIG. 3 VALVE

REF. NO.	PART NO.	DESCRIPTION	B7S2				REMARKS
1	1WS-12111-01	VALVE, INTAKE	4				
2	1WS-12121-00	VALVE, EXHAUST	4				
3	1WS-12113-01	SPRING, VALVE INNER	4				
4	1WS-12114-00	SPRING, VALVE OUTER	4				
5	1WS-12117-00	RETAINER, VALVE SPRING	8				
6	1WG-12118-00	LOCK, VALVE SPRING RETAINER	16				
7	4TE-12119-00	SEAL, VALVE STEM	8				
8	1WS-12116-00	SEAT, VALVE SPRING	8				
9	4C8-12153-10	LIFTER, VALVE	8				YELLOW
	4C8-12153-09	LIFTER, VALVE (O/S)	8				AP GREEN
10	1HX-12168-F0	PAD, ADJUSTING 2 (1.50)	8				UR
	1HX-12168-H1	PAD, ADJUSTING 2 (1.55)	8				UR
	1HX-12168-K1	PAD, ADJUSTING 2 (1.60)	8				UR
	1HX-12168-M1	PAD, ADJUSTING 2 (1.65)	8				UR
	1HX-12168-R1	PAD, ADJUSTING 2 (1.70)	8				UR
	1HX-12168-U1	PAD, ADJUSTING 2 (1.75)	8				UR
	1HX-12168-W1	PAD, ADJUSTING 2 (1.80)	8				UR
	1HX-12168-Y1	PAD, ADJUSTING 2 (1.85)	8				UR
	1HX-12169-11	PAD, ADJUSTING 2 (1.90)	8				UR
	1HX-12169-31	PAD, ADJUSTING 2 (1.95)	8				UR
	1HX-12169-50	PAD, ADJUSTING 2 (2.00)	8				UR
	1HX-12169-70	PAD, ADJUSTING 2 (2.05)	8				UR
	1HX-12169-90	PAD, ADJUSTING 2 (2.10)	8				UR
	1HX-12169-E0	PAD, ADJUSTING 2 (2.15)	8				UR
	1HX-12169-G0	PAD, ADJUSTING 2 (2.20)	8				UR
	1HX-12169-J0	PAD, ADJUSTING 2 (2.25)	8				UR
	1HX-12169-L0	PAD, ADJUSTING 2 (2.30)	8				UR



1WS1300-N041

FIG. 4 CAMSHAFT & CHAIN

REF. NO.	PART NO.	DESCRIPTION	B7S2				REMARKS
1	1WS-12170-00	CAMSHAFT ASSY 1	1				
2	2C0-12176-00	SPROCKET, CAM CHAIN	1				
3	90105-07006	BOLT, FLANGE	2				
4	1WS-12180-00	CAMSHAFT ASSY 2	1				
5	1WS-12181-00	.CAMSHAFT 2	1				
6	90331-16001	.PLUG	1				
7	1WS-12280-00	.DECOMPRESSION ASSY	1				
8	90105-07006	.BOLT, FLANGE	2				
9	1WS-12247-00	.SHAFT, TENSIONER	1				
10	1WS-12257-00	.SHAFT 2	1				
11	1PD-12288-00	.CAM, DECOMPRESSION	2				
12	94591-61134	CHAIN (T098XRH2015-134P)	1				
13	1WS-12210-02	TENSIONER ASSY, CAM CHAIN	1				
14	5EL-12228-00	.BOLT	1				
15	5SL-12214-00	.GASKET	1				
16	1WS-12213-00	GASKET, TENSIONER CASE	1				
17	90110-06396	BOLT, HEXAGON SOCKET HEAD	2				
18	1WS-12251-00	DAMPER, CHAIN 1	1				
19	1WS-12252-00	DAMPER, CHAIN 2	1				
20	90109-06295	BOLT	1				

FIG. 5 WATER PUMP

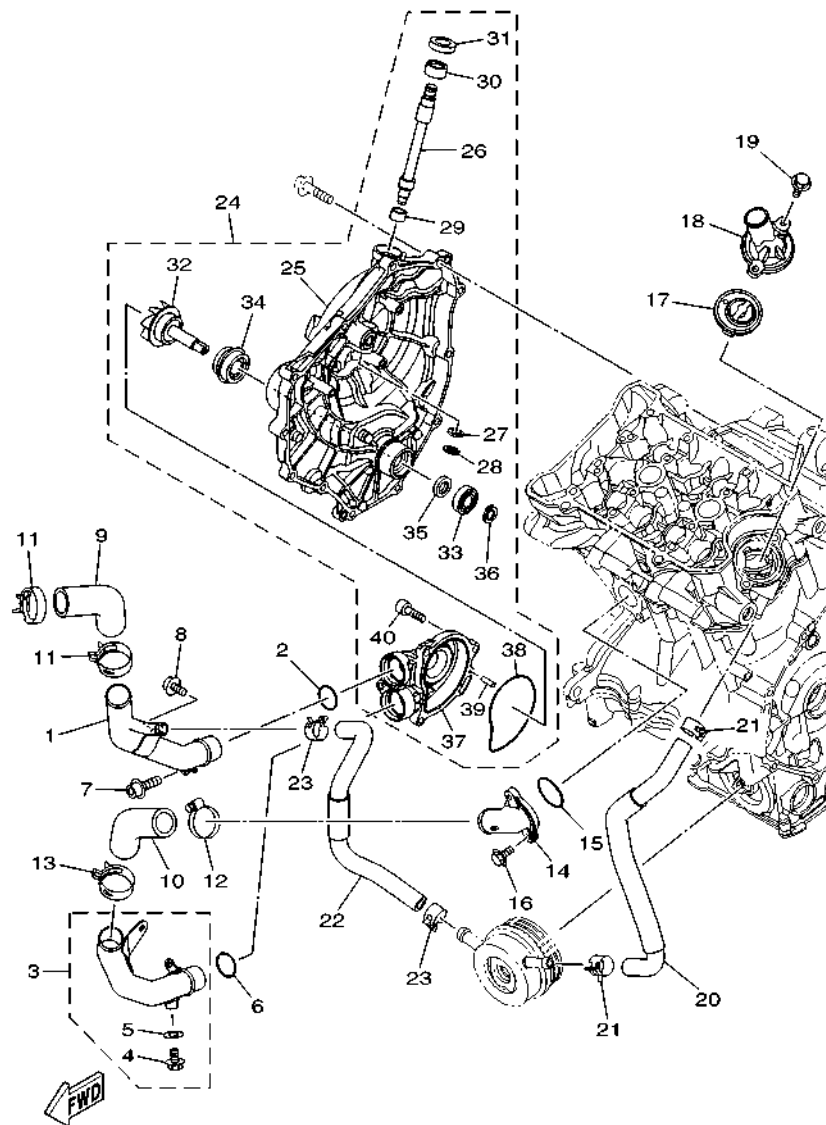

BU28010-S050

REF. NO.	PART NO.	DESCRIPTION	B7S2				REMARKS
1	1WS-12481-00	PIPE 1	1				
2	93210-235A1	O-RING	1				
3	1WS-12482-00	PIPE 2	1				
4	95022-06010	.BOLT, FLANGE	1				
5	90430-06014	.GASKET	1				
6	93210-235A1	O-RING	1				
7	91314-06014	BOLT, HEXAGON SOCKET HEAD	1				
8	90110-06152	BOLT, HEXAGON SOCKET HEAD	1				
9	1WS-12576-00	HOSE 1	1				
10	1WS-12576-00	HOSE 1	1				
11	90467-290A0	CLIP	2				
12	90450-35001	HOSE CLAMP ASSY	1				
13	90467-290A0	CLIP	1				
14	1WS-12469-00	JOINT 1	1				
15	93210-33786	O-RING	1				
16	95812-06020	BOLT, FLANGE	2				
17	1WS-12410-00	THERMOSTAT ASSY	1				
18	1WS-12413-00	COVER, THERMOSTAT	1				
19	95817-06020	BOLT, FLANGE	2				
20	1WS-12588-00	HOSE 5	1				
21	90467-170A6	CLIP	2				
22	1WS-12589-00	HOSE 6	1				
23	90467-170A6	CLIP	2				
24	1WS-12420-01	WATER PUMP ASSY	1				
25	1WS-15421-00	.COVER, CRANKCASE 2	1				
26	2D1-16382-00	.AXLE, PUSH LEVER	1				
27	92907-08600	.WASHER, PLATE	1				

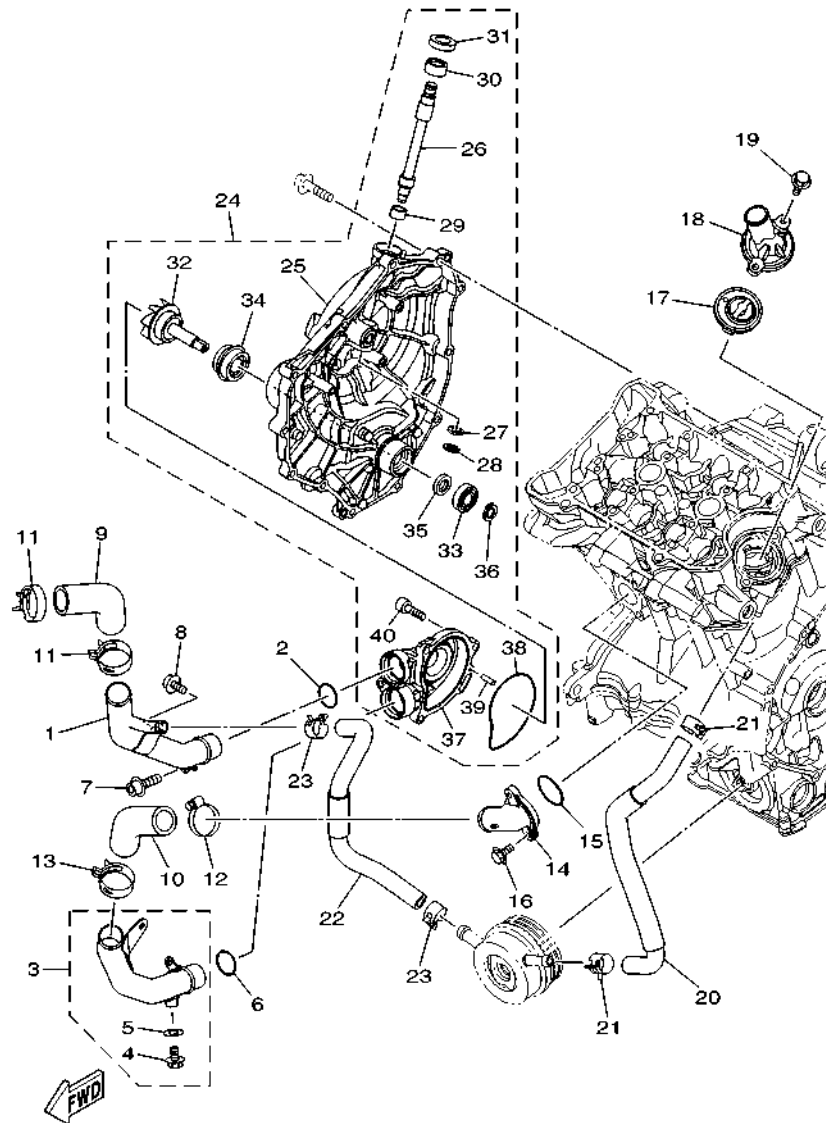

BU28010-S050

FIG. 5 WATER PUMP

REF. NO.	PART NO.	DESCRIPTION	B7S2				REMARKS
28	99001-07600	.CIRCLIP	1				
29	93317-11096	.BEARING	1				
30	93315-21570	.BEARING	1				
31	93102-15212	.OIL SEAL	1				
32	1WS-12450-00	.IMPELLER SHAFT ASSY	1				
33	93306-00106	.BEARING	1				
34	5VK-12438-00	.SEAL, MECHANICAL	1				
35	2CR-13338-00	.SEAL	1				
36	99009-12400	.CIRCLIP	1				
37	1WS-12422-00	.COVER, HOUSING	1				
38	1WS-12439-00	.O-RING	1				
39	93603-12007	.PIN, DOWEL	1				
40	90110-06274	.BOLT, HEXAGON SOCKET HEAD	3				

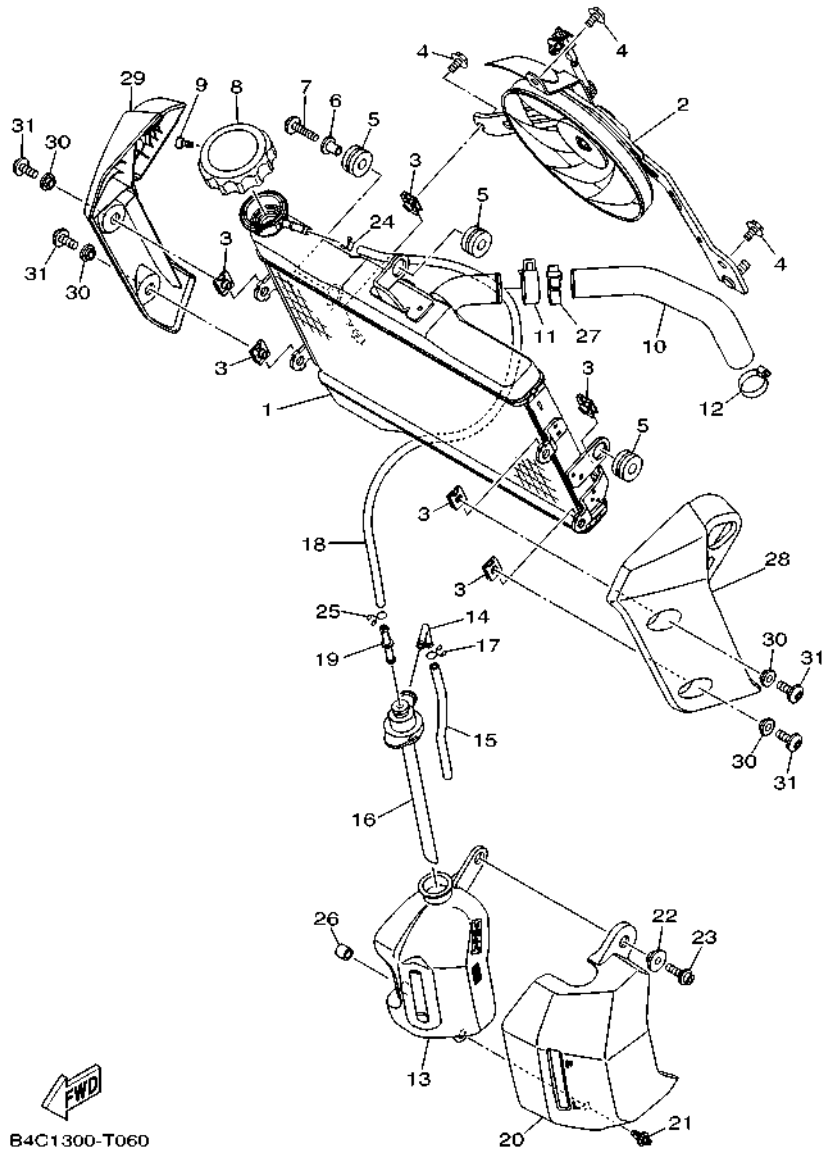

B4C1300-T060

FIG. 6 RADIATOR & HOSE

REF. NO.	PART NO.	DESCRIPTION	B7S2	REMARKS
1	B34-12461-00	RADIATOR COMP	1	
2	1WS-12405-00	BLOWER ASSY	1	
3	1WS-12671-00	NUT 1	6	
4	5GJ-12675-00	BOLT, BLOWER HOLDING	3	
5	90480-15363	GROMMET	3	
6	90387-07391	COLLAR	1	
7	90111-06156	BOLT,HEX. SOCKET BUTTON	1	
8	3D7-12462-00	CAP, RADIATOR	1	
9	91317-03006	BOLT,HEX.SOCKET HEAD	1	
10	1WS-12578-00	HOSE 3	1	
11	90467-290A0	CLIP	1	
12	90450-35001	HOSE CLAMP ASSY	1	
13	1WS-21871-00	TANK, RECOVERY	1	
14	26H-21828-00	ELBOW	1	
15	90445-08020	HOSE	1	
16	3P6-21875-00	CAP	1	
17	90467-08075	CLIP	1	
18	1WS-21816-00	PIPE 1	1	
19	4XY-14568-00	JOINT	1	
20	1WS-2172W-00	COVER	1	
21	90269-06008	RIVET	1	
22	90387-06024	COLLAR	1	
23	90110-06163	BOLT, HEXAGON SOCKET HEAD	1	
24	90467-08075	CLIP	1	
25	90467-08003	CLIP	1	
26	90445-10064	HOSE	1	
27	90464-07M40	CLAMP	1	

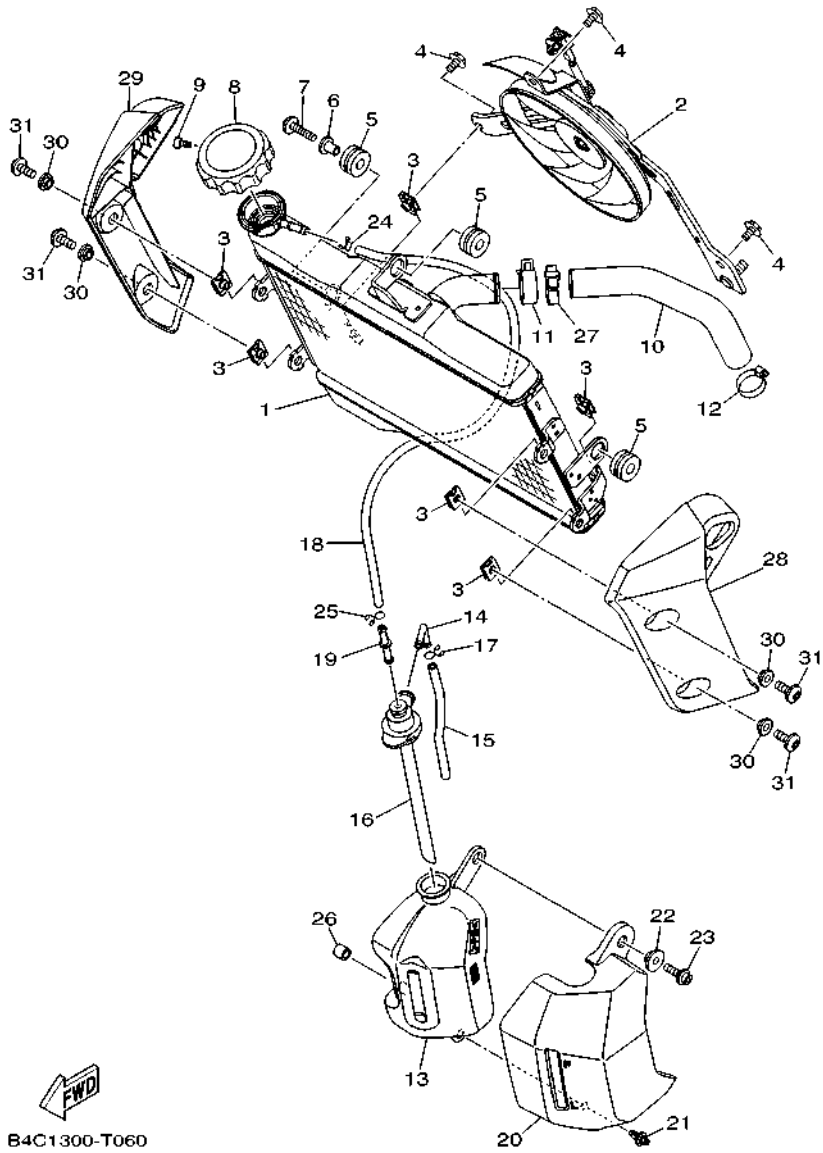

B4C1300-T060

FIG. 6 RADIATOR & HOSE

REF. NO.	PART NO.	DESCRIPTION	B7S2	REMARKS
28	B4C-21731-00	COVER, SIDE 3	1	
29	B4C-21741-00	COVER, SIDE 4	1	
30	90387-06130	COLLAR	4	
31	90111-06151	BOLT,HEX. SOCKET BUTTON	4	
<hr/>				
<hr/>				
<hr/>				
<hr/>				
<hr/>				
<hr/>				
<hr/>				
<hr/>				
<hr/>				
<hr/>				

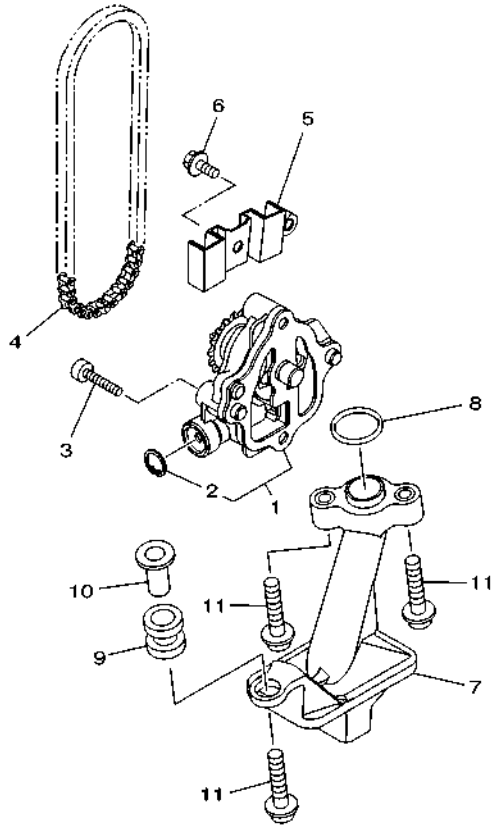
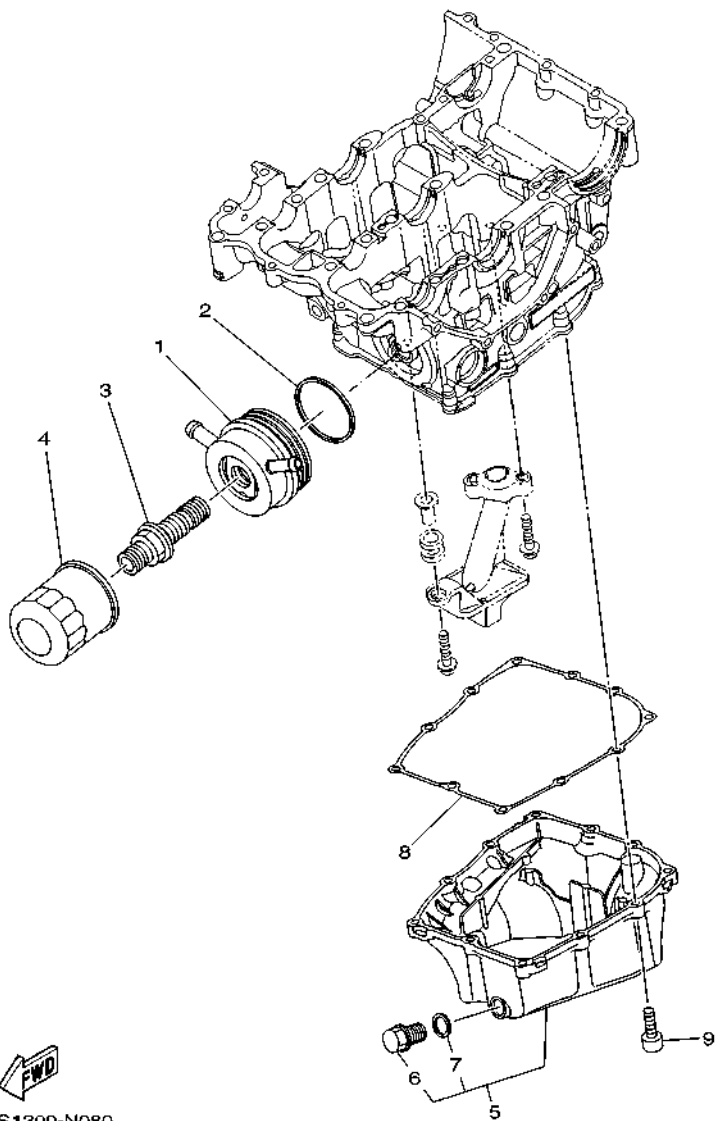

FIG. 7 OIL PUMP

REF. NO.	PART NO.	DESCRIPTION	B7S2	REMARKS
1	1WS-13300-00	OIL PUMP ASSY	1	
2	99009-15500	.CIRCLIP	1	
3	95812-06040	BOLT, FLANGE	4	
4	94581-79060	CHAIN (DID25H-66L)	1	
5	1WS-13898-00	HOLDER	1	
6	90110-06168	BOLT, HEXAGON SOCKET HEAD	2	
7	1WS-13410-00	STRAINER HOUSING ASSY	1	
8	93210-207A0	O-RING	1	
9	90480-13010	GROMMET	1	
10	5VY-13117-10	COLLAR, DISTANCE	1	
11	90110-06173	BOLT, HEXAGON SOCKET HEAD	3	

FIG. 8 OIL CLEANER



1WS1300-N080

REF. NO.	PART NO.	DESCRIPTION	B7S2				REMARKS
1	1WS-13470-00	OIL COOLER ASSY	1				
2	1XD-13475-00	GASKET	1				
3	90401-20009	BOLT, UNION	1				
4	5GH-13440-60	ELEMENT ASSY, OIL CLEANER	1				
5	1WS-13400-00	STRAINER COVER ASSY	1				
6	90340-14132	.PLUG, STRAIGHT SCREW	1				
7	214-11198-01	.GASKET	1				
8	1WS-13414-00	GASKET, STRAINER COVER	1				
9	91312-06030	BOLT, HEXAGON SOCKET HEAD	11				

FIG. 9 INTAKE

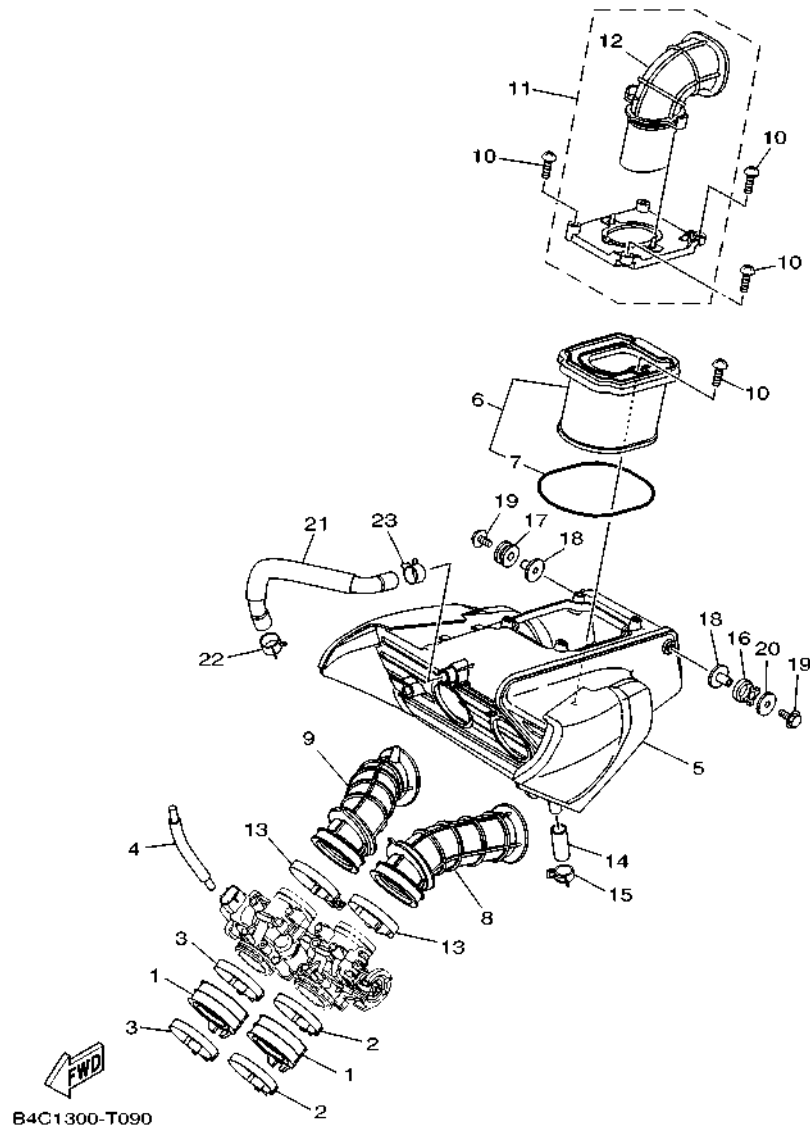

REF. NO.	PART NO.	DESCRIPTION	B7S2				REMARKS
1	1WS-13635-00	JOINT, INTAKE 1	2				
2	90450-56011	HOSE CLAMP ASSY	2				
3	90450-56012	HOSE CLAMP ASSY	2				
4	1WS-13542-00	HOSE, VACUUM SENSING 1	1				
5	B4C-14401-00	AIR CLEANER CASE ASSY	1				
6	1WS-14450-00	ELEMENT ASSY, AIR CLEANER	1				
7	1WS-14452-00	.SEAL	1				
8	1WS-14469-00	FUNNEL, AIR	1				
9	1WS-1446C-00	FUNNEL 2	1				
10	90160-05013	SCREW, ROUND TAPPING	5				
11	1WS-14430-10	DUCT ASSY	1				
12	1WS-14437-10	.DUCT	1				
13	90450-56011	HOSE CLAMP ASSY	2				
14	1WS-1443E-00	PIPE, DRAIN	1				
15	90467-13083	CLIP	1				
16	90480-15001	GROMMET	1				
17	90480-15014	GROMMET	1				
18	90387-06300	COLLAR	2				
19	95817-06025	BOLT, FLANGE	2				
20	90201-064K6	WASHER, PLATE	1				
21	1WS-11166-00	PIPE, BREATHER 1	1				
22	90467-17128	CLIP	1				
23	90467-160A2	CLIP	1				

FIG. 10 INTAKE 2

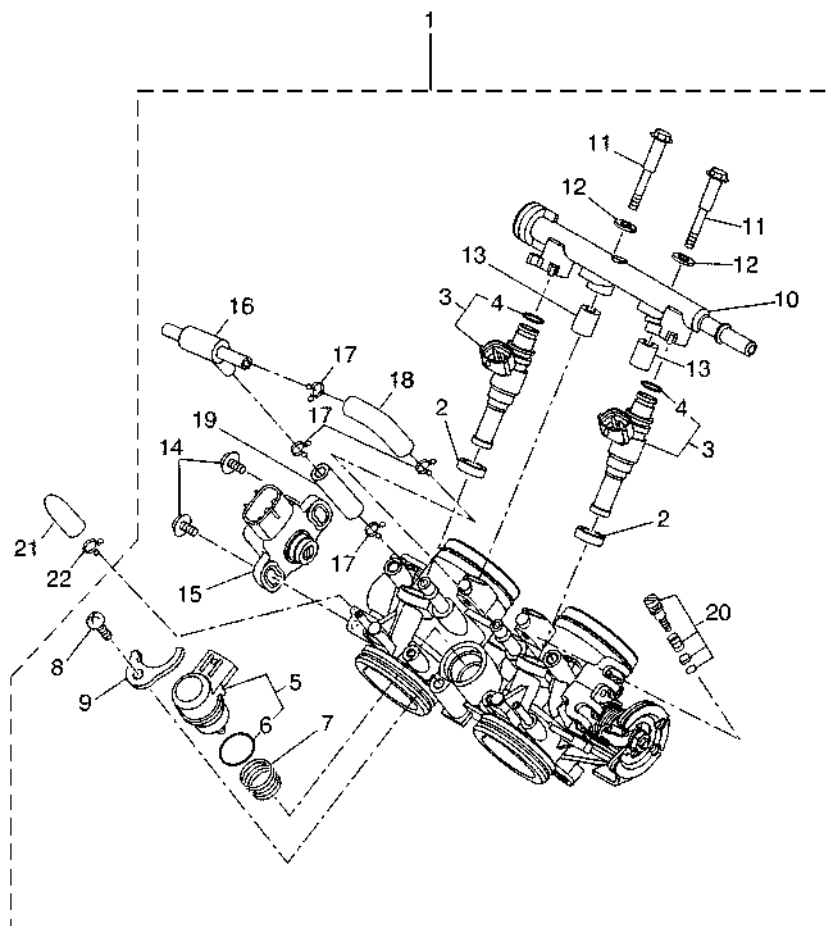

FWD
B341300-R100

REF. NO.	PART NO.	DESCRIPTION	B7S2				REMARKS
1	1WS-13750-10	THROTTLE BODY ASSY	1				
2	8FP-13556-00	.RUBBER, INJECTOR	2				
3	1WS-13761-00	.INJECTOR	2				
4	5PS-14147-00	.O-RING	1				
5	1WS-85801-00	.STEPPING MOTOR	1				
6	54P-E416A-00	.O-RING	1				
7	1WS-14335-00	.SPRING, PLUNGER	1				
8	98502-06012	.SCREW, PAN HEAD	1				
9	54P-14243-00	.PLATE	1				
10	1WS-13938-00	.PIPE	1				
11	8HG-13573-00	.BOLT 1	2				
12	8GL-13571-00	.WASHER	2				
13	8HG-14534-00	.COLLAR	2				
14	8CC-14216-10	.SCREW	2				
15	3B4-85885-00	.THROTTLE SENSOR ASSY	1				
16	90413-06031	.WAY 3	1				
17	90467-090A2	.CLIP	4				
18	1WS-14465-00	.PIPE	1				
19	14B-14466-00	.PIPE	1				
20	2C0-14105-00	.PILOT SCREW SET	2				
21	895-14169-00	CAP	1				
22	8A7-14139-00	CLIP, PIPE	1				

FIG. 11 EXHAUST

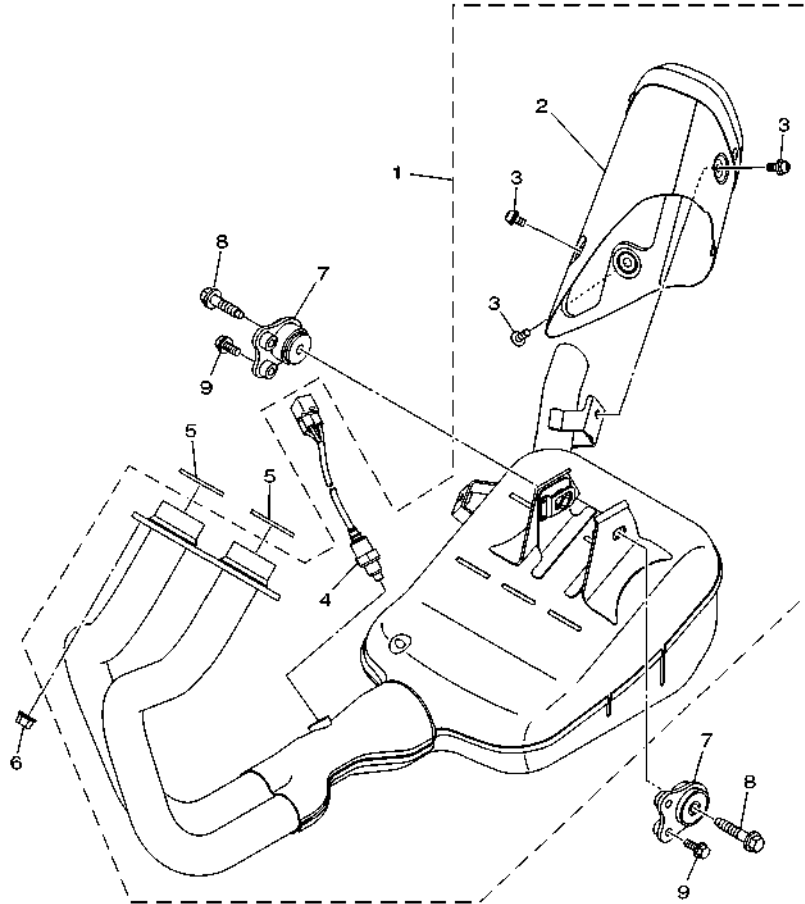

1WS1300-N110

REF. NO.	PART NO.	DESCRIPTION	B7S2				REMARKS
1	BU2-14710-00	MUFFLER ASSY 1	1				
2	1WS-14708-00	.PROTECTOR ASSY	1				
3	90111-06060	.BOLT HEX. SOCKET BUTTON	3				
4	1WS-8592A-00	.SENSOR, OXYGEN	1				
5	3YF-14613-01	GASKET, EXHAUST PIPE	2				
6	90179-08410	NUT	4				
7	20S-21445-01	STAY, MUFFLER 1	2				
8	90105-08164	BOLT, FLANGE	2				
9	95D34-06016	BOLT, FLANGE DEEP RECESS	4				

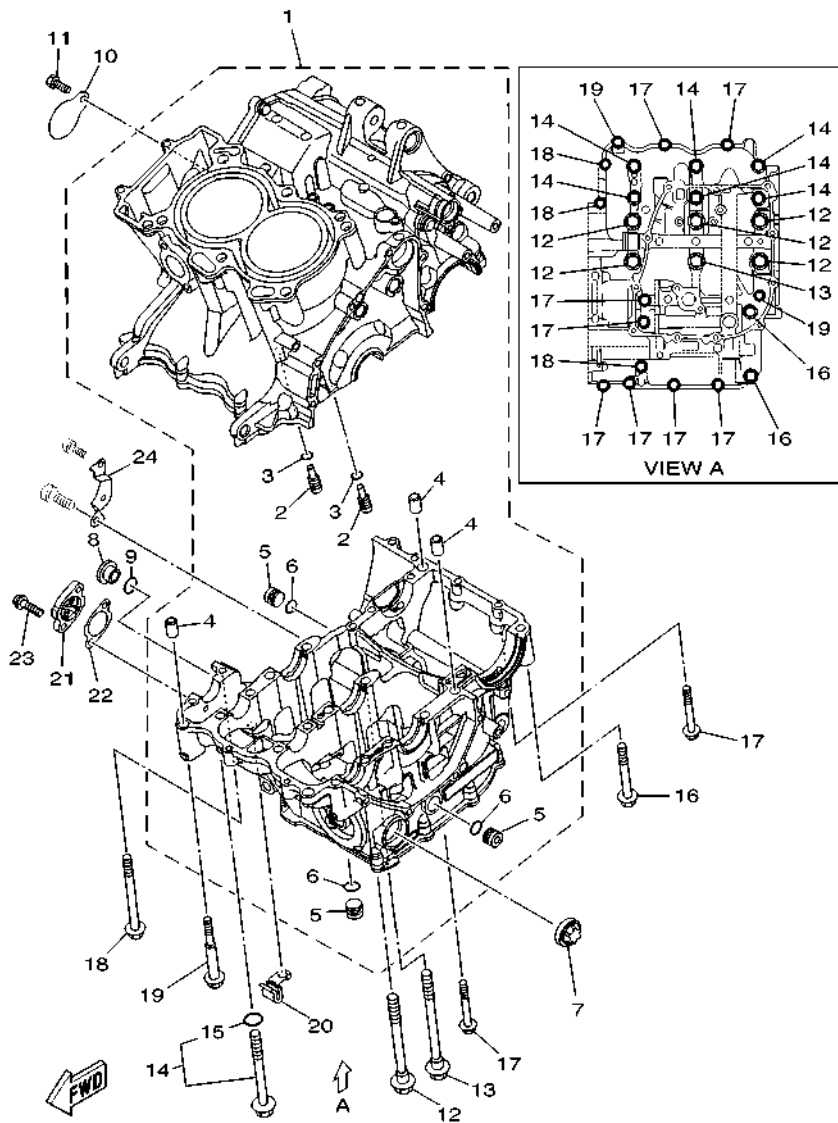

B4C7431-T120

FIG. 12 CRANKCASE

REF. NO.	PART NO.	DESCRIPTION	B7S2	REMARKS
1	1WS-15100-08	CRANKCASE ASSY	1	
2	5EB-15155-00	.NOZZLE 3	2	
3	93210-04092	.O-RING	2	
4	99530-10014	.PIN, DOWEL	3	
5	90338-16262	.PLUG	3	
6	93210-12790	.O-RING	3	
7	2H7-15361-00	GAUGE, LEVEL	1	
8	36Y-15189-00	PLUG	1	
9	93210-16325	O-RING	1	
10	1WS-15189-00	PLUG	1	
11	90101-06043	BOLT	1	
12	90119-09014	BOLT, WITH WASHER	5	(M9X1.25 - 80mm)
13	90119-09018	BOLT, WITH WASHER	1	(M9X1.25 - 90mm)
14	1WS-15156-00	BOLT, CRANKCASE JOURNAL	6	
15	93210-07540	.O-RING	1	
16	95812-08065	BOLT, FLANGE	2	
17	95812-06040	BOLT, FLANGE	8	
18	95812-06060	BOLT, FLANGE	3	
19	90109-06100	BOLT	2	
20	90462-10064	CLAMP	1	
21	1WS-15416-00	COVER, OIL PUMP	1	
22	1WS-15456-00	GASKET, OIL PUMP COVER 1	1	
23	90110-06395	BOLT, HEXAGON SOCKET HEAD	2	
24	1WS-15128-00	HOLDER	1	

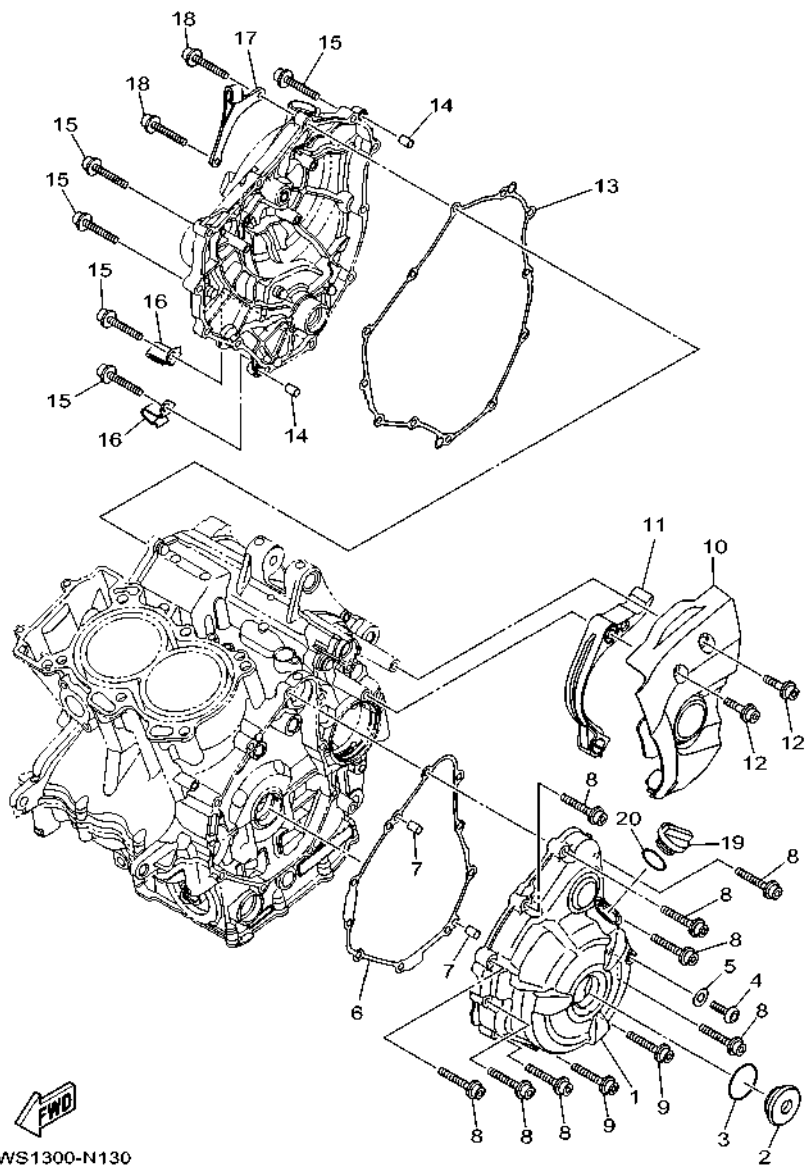

1WS1300-N130

FIG. 13 CRANKCASE COVER 1

REF. NO.	PART NO.	DESCRIPTION	B7S2	REMARKS
1	1WS-15411-00	COVER, CRANKCASE 1	1	
2	90340-36005	PLUG, STRAIGHT SCREW	1	
3	93210-357A3	O-RING	1	
4	92017-08012	BOLT, BUTTON HEAD	1	
5	90430-08143	GASKET	1	
6	1WS-15451-00	GASKET, CRANKCASE COVER 1	1	
7	99530-08012	PIN, DOWEL	2	
8	90110-06388	BOLT, HEXAGON SOCKET HEAD	8	
9	90110-06389	BOLT, HEXAGON SOCKET HEAD	2	
10	1WS-15418-00	COVER, CHAIN CASE	1	
11	1WS-15377-00	GUIDE, INLET	1	
12	90110-06396	BOLT, HEXAGON SOCKET HEAD	3	
13	1WS-15461-00	GASKET, CRANKCASE COVER 2	1	
14	99530-08012	PIN, DOWEL	2	
15	90110-06388	BOLT, HEXAGON SOCKET HEAD	10	
16	90465-08045	CLAMP	2	
17	1WS-15441-00	HOLDER, CLUTCH CABLE	1	
18	90110-06389	BOLT, HEXAGON SOCKET HEAD	2	
19	3F9-15362-10	PLUG, OIL LEVEL	1	
20	93210-27194	O-RING	1	

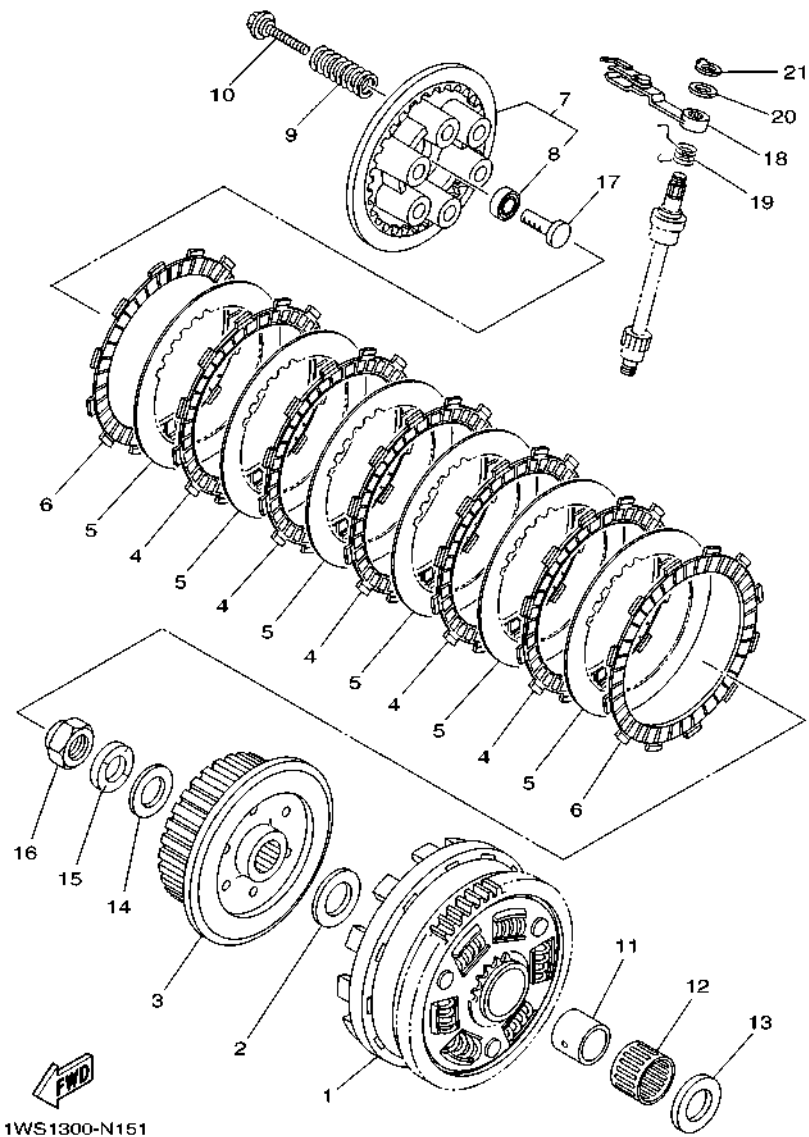

FIG. 15 CLUTCH

REF. NO.	PART NO.	DESCRIPTION	B7S2	REMARKS
1	1WS-16150-00	PRIMARY DRIVEN GEAR COMP.	1	
2	363-16154-00	PLATE, THRUST 1	1	
3	1WS-16371-01	BOSS, CLUTCH	1	
4	5VY-16321-00	PLATE, FRICTION	5	
5	5VY-16325-00	PLATE, CLUTCH 2	6	(T2.0)
6	5TG-16321-00	PLATE, FRICTION	2	
7	1WS-16350-00	PRESSURE PLATE ASSY	1	
8	93306-00106	.BEARING	1	
9	90501-230E4	SPRING, COMPRESSION	6	
10	90119-06263	BOLT, WITH WASHER	6	
11	1WS-16181-00	SPACER 1	1	
12	93310-232R9	BEARING	1	
13	363-16154-00	PLATE, THRUST 1	1	
14	90201-20030	WASHER, PLATE	1	
15	90208-20001	WASHER, CONICAL SPRING	1	
16	90179-20007	NUT	1	
17	1WS-16356-00	ROD, PUSH 1	1	
18	1WS-16340-00	PUSH LEVER ASSY	1	
19	90508-18132	SPRING, TORSION	1	
20	90201-10029	WASHER, PLATE	1	
21	99009-10400	CIRCLIP	1	

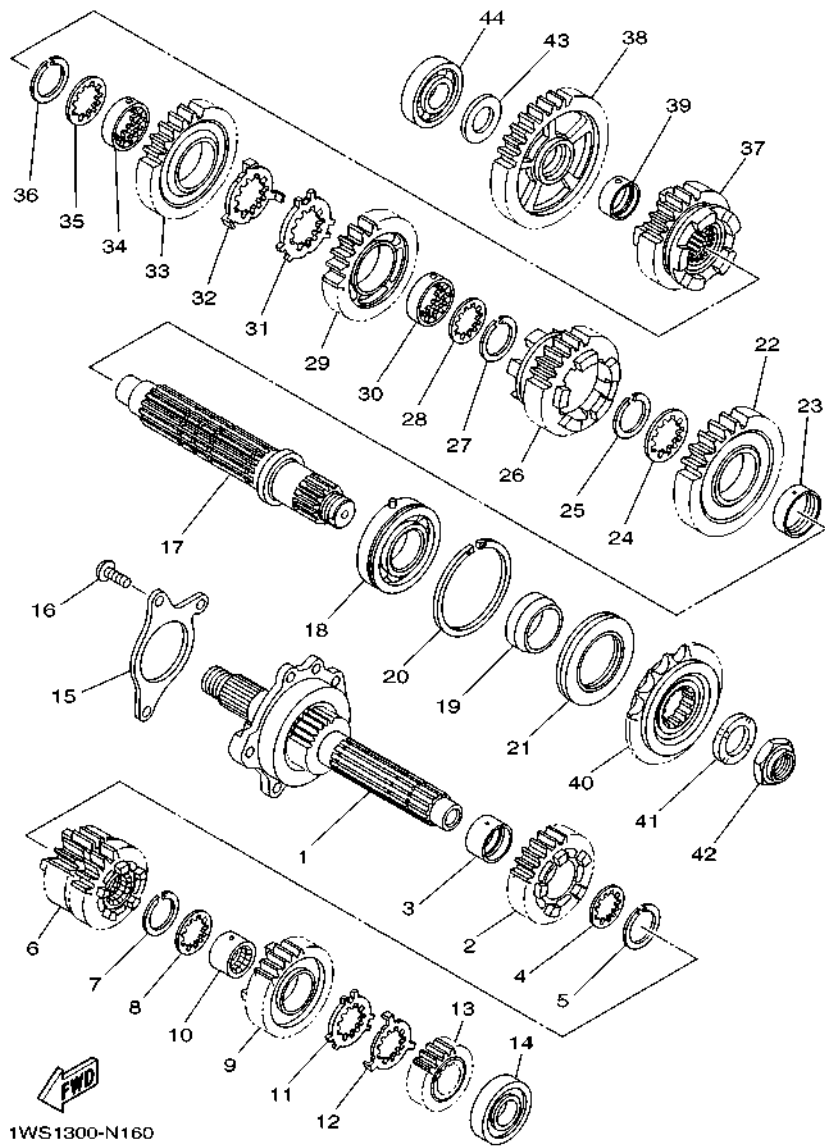

FIG. 16 TRANSMISSION

REF. NO.	PART NO.	DESCRIPTION	B7S2	REMARKS
1	1WS-17401-00	MAIN AXLE ASSY	1	
2	1WS-17151-00	GEAR, 5TH PINION (22T)	1	
3	90387-250R3	COLLAR	1	
4	90209-21332	WASHER	1	
5	93440-25186	CIRCLIP	1	
6	1WS-17131-00	GEAR, 3RD PINION (20T/19T)	1	
7	93440-25186	CIRCLIP	1	
8	90209-21332	WASHER	1	
9	1WS-17161-00	GEAR, 6TH PINION (28T)	1	
10	90387-21003	COLLAR	1	
11	90209-22352	WASHER	1	
12	90209-21351	WASHER	1	
13	1WS-17121-00	GEAR, 2ND PINION (16T)	1	
14	93306-20464	BEARING	1	
15	1WS-17446-00	PLATE	1	
16	90149-06189	SCREW	3	
17	1WS-17421-00	AXLE, DRIVE	1	
18	93306-20663	BEARING	1	
19	90387-30012	COLLAR	1	
20	93440-64199	CIRCLIP	1	
21	93102-40030	OIL SEAL	1	
22	1WS-17221-00	GEAR, 2ND WHEEL (34T)	1	
23	90387-31003	COLLAR	1	
24	90209-28008	WASHER	1	
25	93440-31187	CIRCLIP	1	
26	1WS-17261-00	GEAR, 6TH WHEEL (27T)	1	
27	93440-31187	CIRCLIP	1	

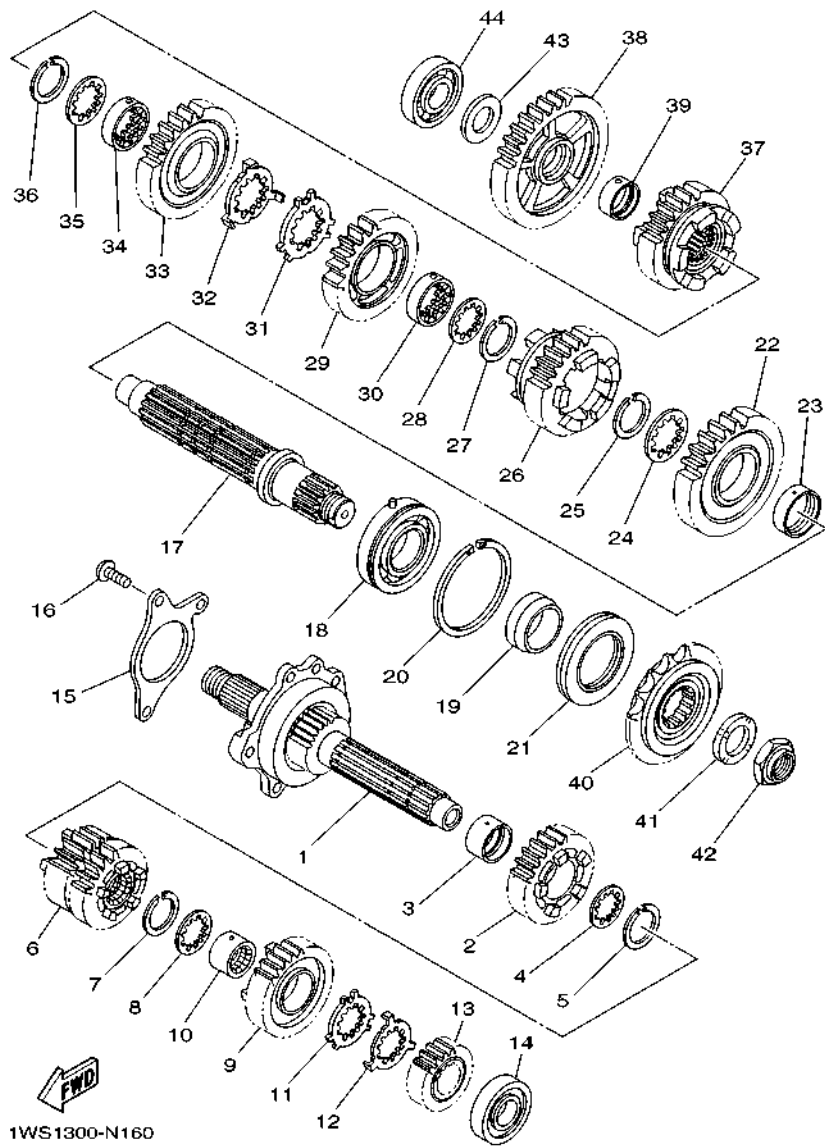
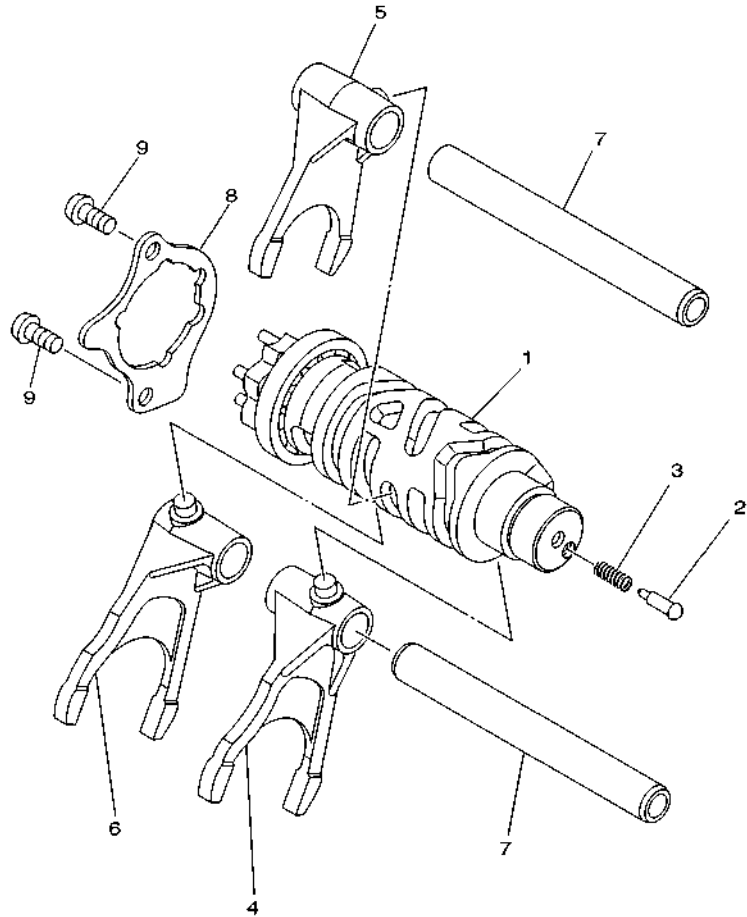

FIG. 16 TRANSMISSION

REF. NO.	PART NO.	DESCRIPTION	B7S2				REMARKS
28	90209-28008	WASHER	1				
29	1WS-17241-00	GEAR, 4TH WHEEL (26T)	1				
30	90387-28004	COLLAR	1				
31	90214-29002	WASHER, CLAW	1				
32	90214-28002	WASHER, CLAW	1				
33	1WS-17231-00	GEAR, 3RD WHEEL (31T)	1				
34	90387-28004	COLLAR	1				
35	90209-28008	WASHER	1				
36	93440-31187	CIRCLIP	1				
37	1WS-17251-00	GEAR, 5TH WHEEL (24T)	1				
38	1WS-17211-00	GEAR, 1ST WHEEL (37T)	1				
39	90387-25008	COLLAR	1				
40	1WS-17460-00	SPROCKET, DRIVE (16T)	1				
41	90208-22002	WASHER, CONICAL SPRING	1				
42	90179-22018	NUT	1				
43	90201-20008	WASHER, PLATE	1				
44	93306-20464	BEARING	1				

FIG. 17 SHIFT CAM & FORK



REF. NO.	PART NO.	DESCRIPTION	B7S2	REMARKS
1	1WS-18540-00	SHIFT CAM ASSY	1	
2	3D7-18542-00	POINT, NEUTRAL	1	
3	90501-06022	SPRING, COMPRESSION	1	
4	1WS-18511-00	FORK, SHIFT 1	1	
5	1WS-18512-00	FORK, SHIFT 2	1	
6	1WS-18513-00	FORK, SHIFT 3	1	
7	20S-18535-00	BAR, SHIFT FORK GUIDE 2	2	
8	1WS-18536-00	STOPPER, SHIFT BAR	1	
9	90149-06158	SCREW	2	



1WS1300-N170

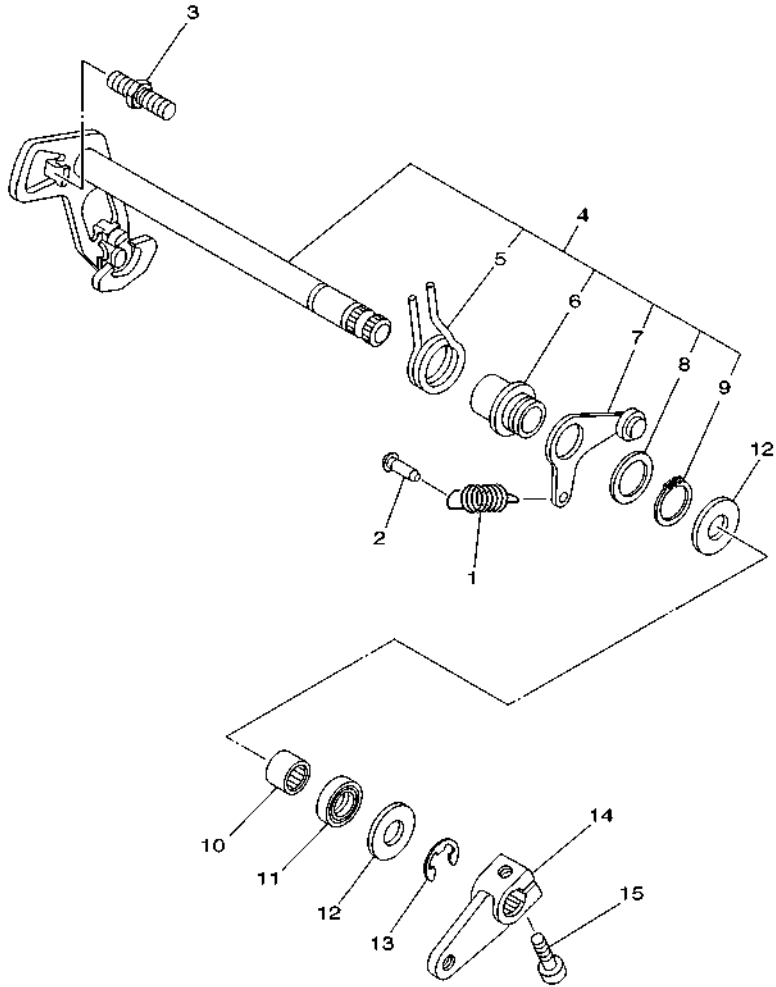

1WS1300-N180

FIG. 18 SHIFT SHAFT

REF. NO.	PART NO.	DESCRIPTION	B7S2				REMARKS
1	90506-18021	SPRING, TENSION	1				
2	132-16346-00	HOOK, SPRING	1				
3	1D7-18127-00	STOPPER, SCREW	1				
4	1WS-18101-00	SHIFT SHAFT ASSY	1				
5	90508-29040	.SPRING, TORSION	1				
6	2C0-18175-00	.SPACER	1				
7	1WS-18140-00	.STOPPER LEVER ASSY	1				
8	90201-177G4	.WASHER, PLATE	1				
9	99009-17400	.CIRCLIP	1				
10	93317-11295	BEARING	1				
11	93102-12106	OIL SEAL (SD 12-22-5 HS)	1				
12	90201-12575	WASHER, PLATE	2				
13	99002-10600	CIRCLIP	1				
14	1WS-18112-00	ARM, SHIFT	1				
15	91317-06020	BOLT,HEX.SOCKET HEAD	1				

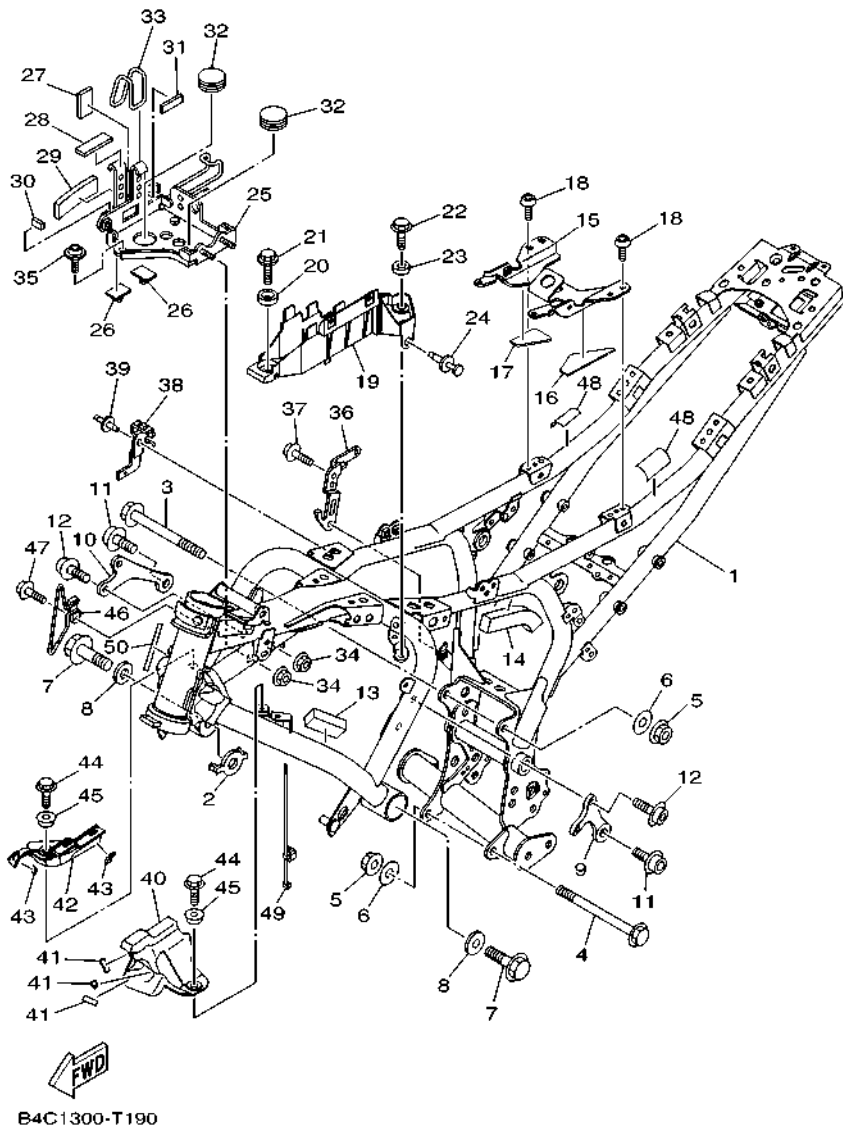

FIG. 19 FRAME

REF. NO.	PART NO.	DESCRIPTION	B7S2				REMARKS
1	BU2-21110-10	FRAME COMP.	1				
2	1WS-2191B-00	PLATE 1	1				
3	90105-10219	BOLT, FLANGE	1				
4	90105-10349	BOLT, FLANGE	1				
5	90179-10024	NUT	2				
6	90201-10035	WASHER, PLATE	2				
7	90105-12092	BOLT, FLANGE	2				
8	90201-13020	WASHER, PLATE	2				
9	1WS-21315-00	STAY, ENGINE 1	1				
10	1WS-21316-00	STAY, ENGINE 2	1				
11	90110-10044	BOLT, HEXAGON SOCKET HEAD	2				
12	90110-08111	BOLT, HEXAGON SOCKET HEAD	4				
13	90520-20004	DAMPER, PLATE	1				
14	90520-20003	DAMPER, PLATE	1				
15	B4C-21946-00	BRACKET, SEAT FITTING	1				
16	B4C-2112B-00	SEAT 1	1				
17	B4C-2113C-00	SHEET,2	1				
18	92012-06010	BOLT, BUTTON HEAD	4				
19	1WS-2117N-00	COVER 3	1				
20	90387-1001B	COLLAR	1				
21	90119-06209	BOLT, WITH WASHER	1				
22	95D32-06012	BOLT, FLANGE DEEP RECESS	1				
23	90387-06372	COLLAR	1				
24	90269-06002	RIVET	1				
25	1WS-21158-00	BRACKET	1				
26	90464-25160	CLAMP	2				
27	90520-01004	DAMPER, PLATE	1				

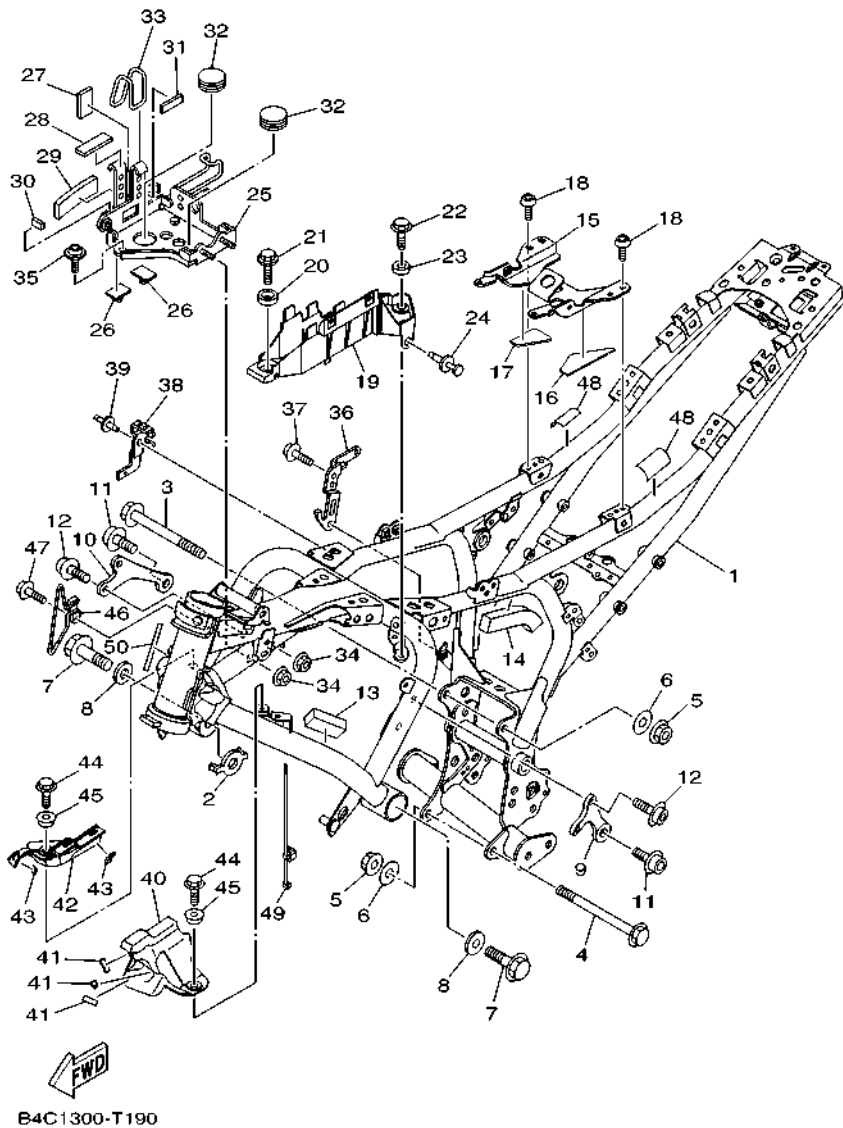
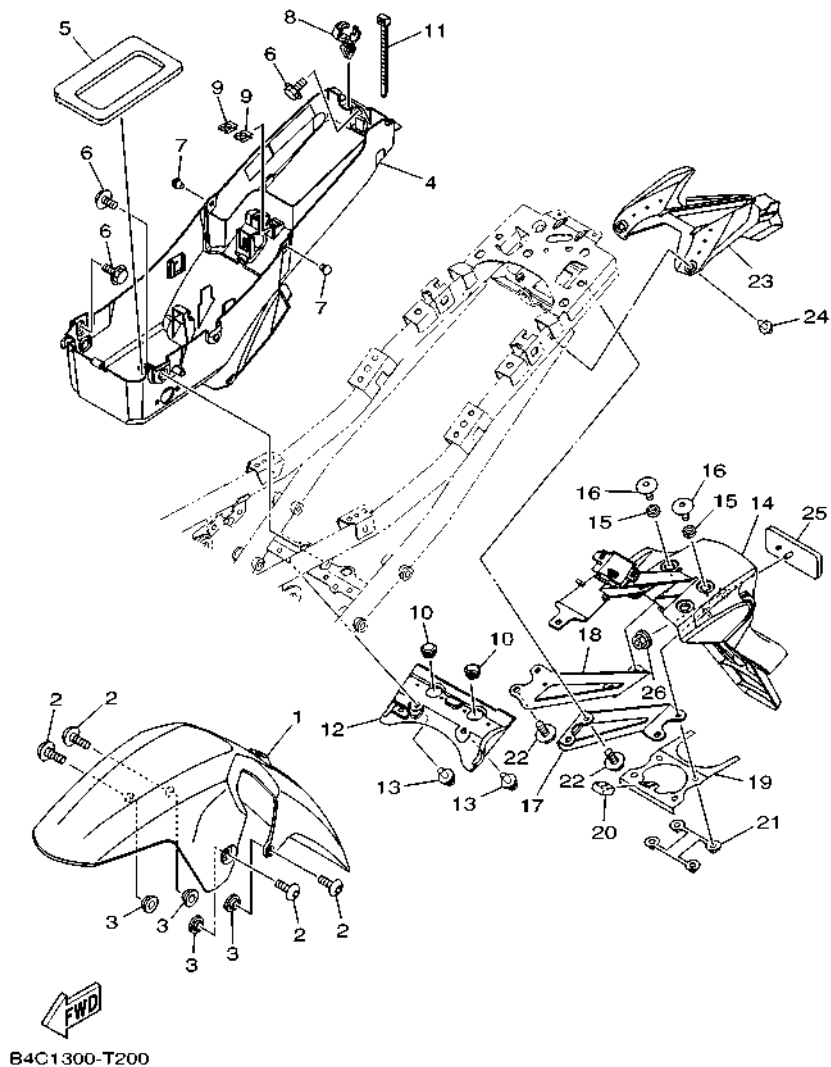

FIG. 19 FRAME

REF. NO.	PART NO.	DESCRIPTION	B7S2			REMARKS
28	3UF-24737-00	DAMPER, SEAT	1			
29	3KJ-15337-00	DAMPER 4	1			
30	1HX-27415-00	PLATE, DAMPER	1			
31	5DM-28371-00	DAMPER	1			
32	90480-30167	GROMMET	2			
33	4XV-21376-00	BAND, TOOL	1			
34	95702-06500	NUT, FLANGE	2			
35	90111-06122	BOLT, HEX. SOCKET BUTTON	1			
36	1WS-2161J-00	BRACKET 8	1			
37	92017-06010	BOLT, BUTTON HEAD	1			
38	1WS-2175U-00	BRACKET 2	1			
39	90269-07077	RIVET	1			
40	1WS-2117R-00	COVER 4	1			
41	1HX-27415-00	PLATE, DAMPER	3			
42	1WS-2117T-00	COVER 5	1			
43	1HX-27415-00	PLATE, DAMPER	2			
44	95D07-06012	BOLT, FLANGE DEEP RECESS	2			
45	90387-062M9	COLLAR	2			
46	BU2-21288-00	GUIDE, CABLE	1			
47	95027-06010	BOLT, FLANGE	1			
48	5VN-21268-00	SEAL	2			
49	90464-45003	CLAMP	1			
50	3HA-24141-00	PROTECTOR, FUEL TANK	1			

FIG. 20 FENDER



REF. NO.	PART NO.	DESCRIPTION	B7S2				REMARKS
1	B4C-21511-00	FENDER, FRONT	1				
2	90111-06151	BOLT,HEX. SOCKET BUTTON	4				
3	90387-06153	COLLAR	4				
4	1WS-8212B-00	BOX, BATTERY 1	1				
5	1WS-21639-00	DAMPER 2	1				
6	90109-06202	BOLT	3				
7	90338-06018	PLUG	2				
8	90464-18002	CLAMP	1				
9	90183-04039	NUT, SPRING	2				
10	90480-14100	GROMMET	2				
11	90465-13275	CLAMP	1				
12	1WS-21642-00	GUARD, FLAP	1				
13	90269-06002	RIVET	2				
14	1WS-21629-00	GUARD, MUD	1				
15	90387-06372	COLLAR	4				
16	90111-06089	BOLT,HEX. SOCKET BUTTON	4				
17	1WS-2164F-00	STAY 1	1				
18	1WS-2164G-00	STAY 2	1				
19	1WS-21682-00	STAY, PLATE	1				
20	1WS-21746-00	DAMPER	1				
21	1WS-2161G-00	BRACKET 6	1				
22	90105-06206	BOLT, FLANGE	4				
23	1WS-2163A-00	COVER, REAR FENDER 1	1				
24	90269-07008	RIVET	2				
25	3Y6-85130-02	REAR REFLECTOR ASSY	1				
26	95602-05200	NUT, SELF-LOCKING	1				

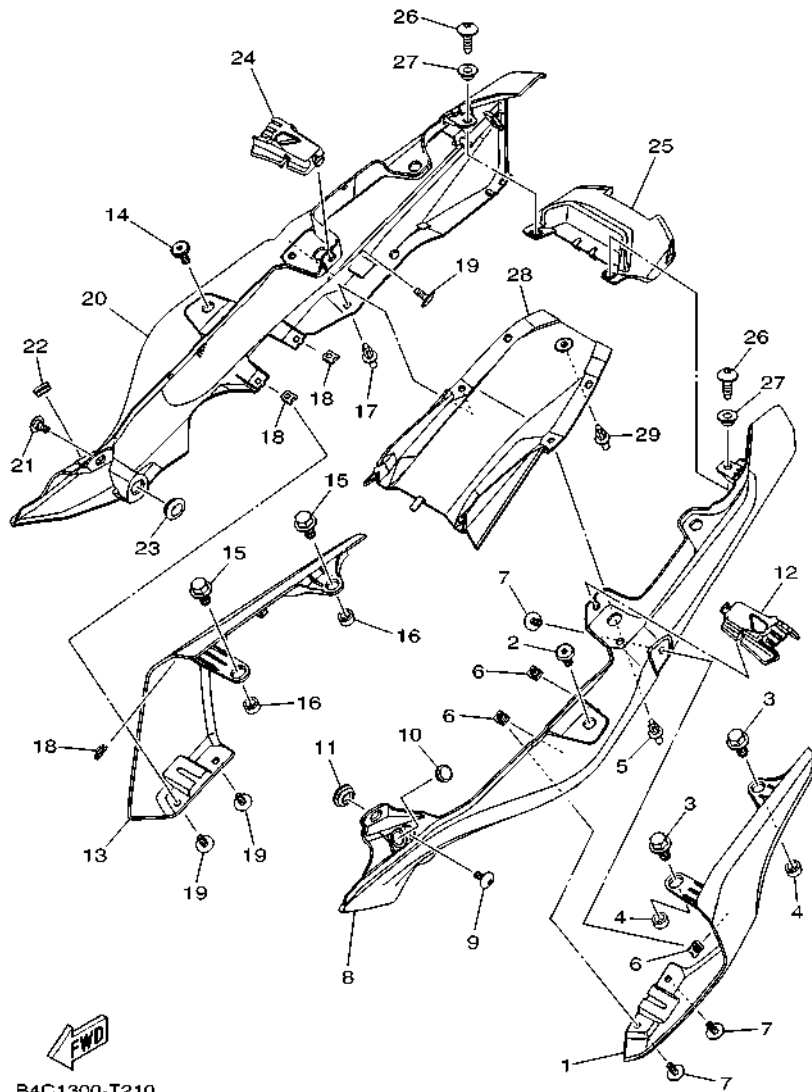
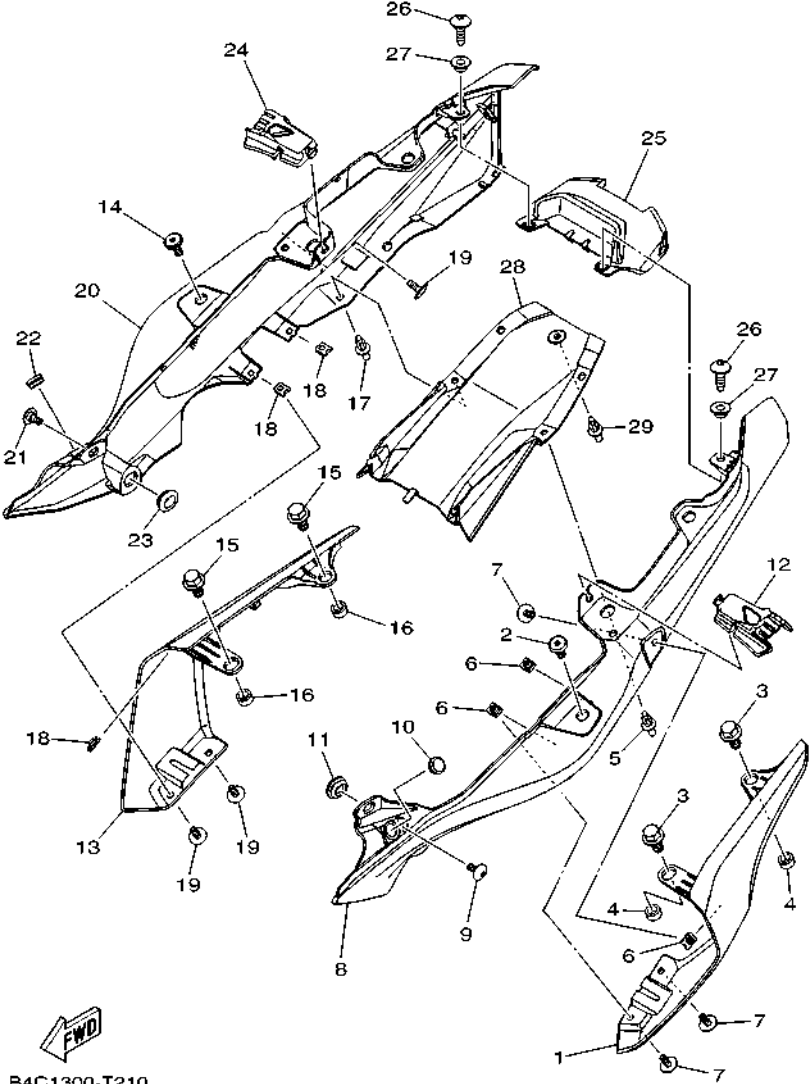

FIG. 21 SIDE COVER

REF. NO.	PART NO.	DESCRIPTION	B7S2	REMARKS
1	B4C-21711-00-33	COVER, SIDE 1	1	UR YB FOR DPBMC
	B4C-21711-00-P3	COVER, SIDE 1	1	UR FOR MLNM4
2	90109-06259	BOLT	1	
3	90105-08021	BOLT, FLANGE	2	
4	90387-08088	COLLAR	2	
5	90269-06008	RIVET	1	
6	90183-05076	NUT, SPRING	3	
7	90111-05003	BOLT,HEX. SOCKET BUTTON	3	
8	B4C-2171E-00	COVER, SIDE 5	1	
9	90111-05011	BOLT,HEX. SOCKET BUTTON	1	
10	90480-14100	GROMMET	1	
11	90480-01559	GROMMET	1	
12	B4C-2171L-00	MOLE, SIDE COVER 1	1	
13	B4C-21721-00-33	COVER, SIDE 2	1	UR YB FOR DPBMC
	B4C-21721-00-P3	COVER, SIDE 2	1	UR FOR MLNM4
14	90109-06259	BOLT	1	
15	90105-08021	BOLT, FLANGE	2	
16	90387-08088	COLLAR	2	
17	90269-06008	RIVET	1	
18	90183-05076	NUT, SPRING	3	
19	90111-05003	BOLT,HEX. SOCKET BUTTON	3	
20	B4C-2171X-00	COVER, SIDE 6	1	
21	90111-05011	BOLT,HEX. SOCKET BUTTON	1	
22	90480-14100	GROMMET	1	
23	90480-01559	GROMMET	1	
24	B4C-2171M-00	MOLE, SIDE COVER 2	1	
25	B4C-2172X-00	COVER, TAILLIGHT	1	

FIG. 21 SIDE COVER



B4C1300-T210

REF. NO.	PART NO.	DESCRIPTION	B7S2				REMARKS
26	90167-05076	SCREW, TAPPING	2				
27	90387-05021	COLLAR	2				
28	1WS-21651-00	COVER, REAR FENDER	1				
29	90269-06008	RIVET	1				

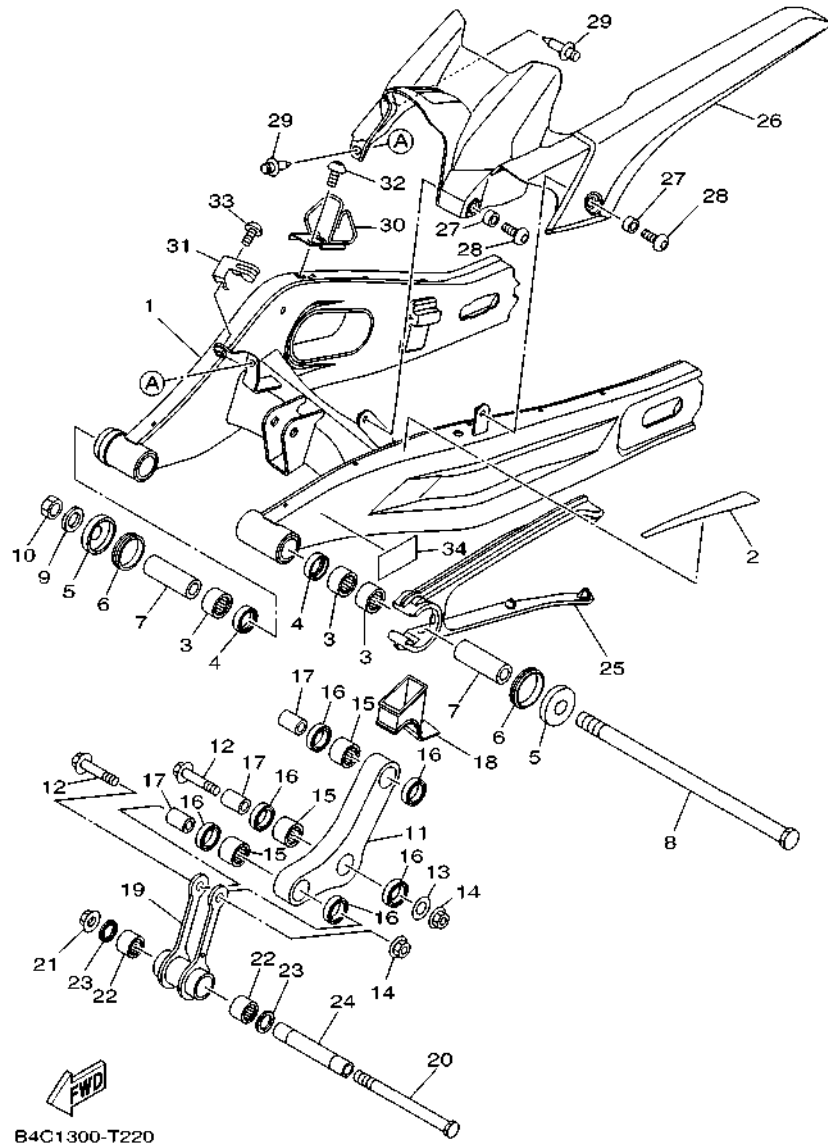

B4C1300-T220

FIG. 22 REAR ARM

REF. NO.	PART NO.	DESCRIPTION	B7S2				REMARKS
1	1WS-22110-10	REAR ARM COMP.	1				
2	BU2-22358-00	SEAL 1	1				
3	93317-22262	BEARING	3				
4	93106-22019	OIL SEAL (DC 22-28-8)	2				
5	30X-2219X-00	COVER	2				
6	93108-35004	OIL SEAL (35-41-8)	2				
7	90380-16158	BUSH, SOLID	2				
8	1UY-22141-10	SHAFT, PIVOT	1				
9	90201-164H4	WASHER, PLATE	1				
10	90185-16002	NUT, SELF-LOCKING	1				
11	1WS-2217A-00	ARM, RELAY	1				
12	90105-102A6	BOLT, FLANGE	2				
13	90201-10045	WASHER, PLATE	1				
14	95602-10200	NUT, S/L FLANGE	2				
15	93315-31758	BEARING	3				
16	93109-17071	OIL SEAL	6				
17	90387-1012A	COLLAR	3				
18	1WS-22189-00	BOOT, RUBBER	1				
19	1WS-2217F-00	ROD, CONNECTING 1	1				
20	90101-12049	BOLT	1				
21	95602-12200	NUT, SELF-LOCKING	1				
22	93317-31771	BEARING	2				
23	93109-17071	OIL SEAL	2				
24	1WS-22184-00	BUSH	1				
25	1WS-22151-00	SEAL, GUARD	1				
26	B4C-21650-00	REAR FENDER COMP.	1				
27	90387-06344	COLLAR	2				

FIG. 23 REAR SUSPENSION

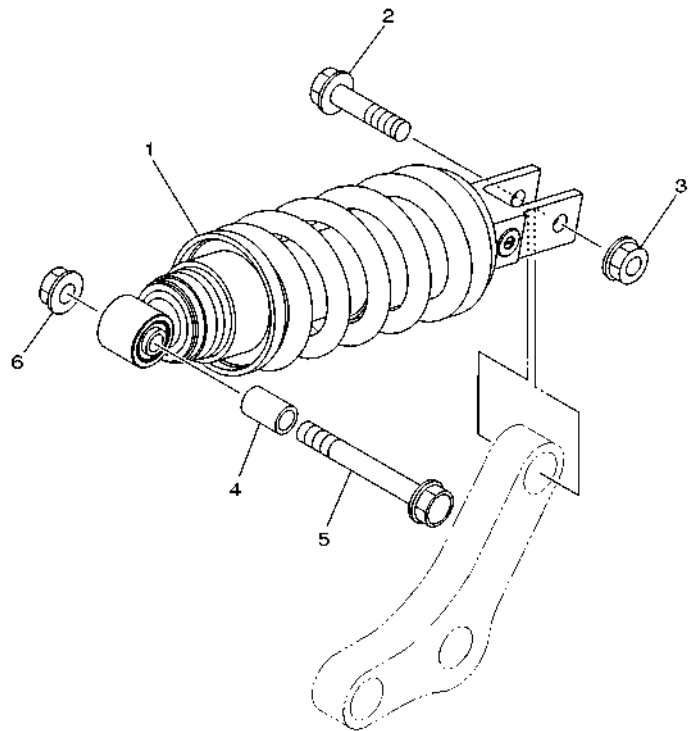

B4C1300-T230

REF. NO.	PART NO.	DESCRIPTION	B7S2			REMARKS
1	B4C-22210-00	SHOCK ABSORBER ASSY, REAR	1			UR FOR DPBMC
	B4C-22210-40	SHOCK ABSORBER ASSY, REAR	1			UR FOR MLNM4
2	90105-10283	BOLT, FLANGE	1			
3	95602-10200	NUT, S/L FLANGE	1			
4	90387-1012A	COLLAR	1			
5	90105-10212	BOLT, FLANGE	1			
6	95602-10200	NUT, S/L FLANGE	1			

FIG. 24 STEERING

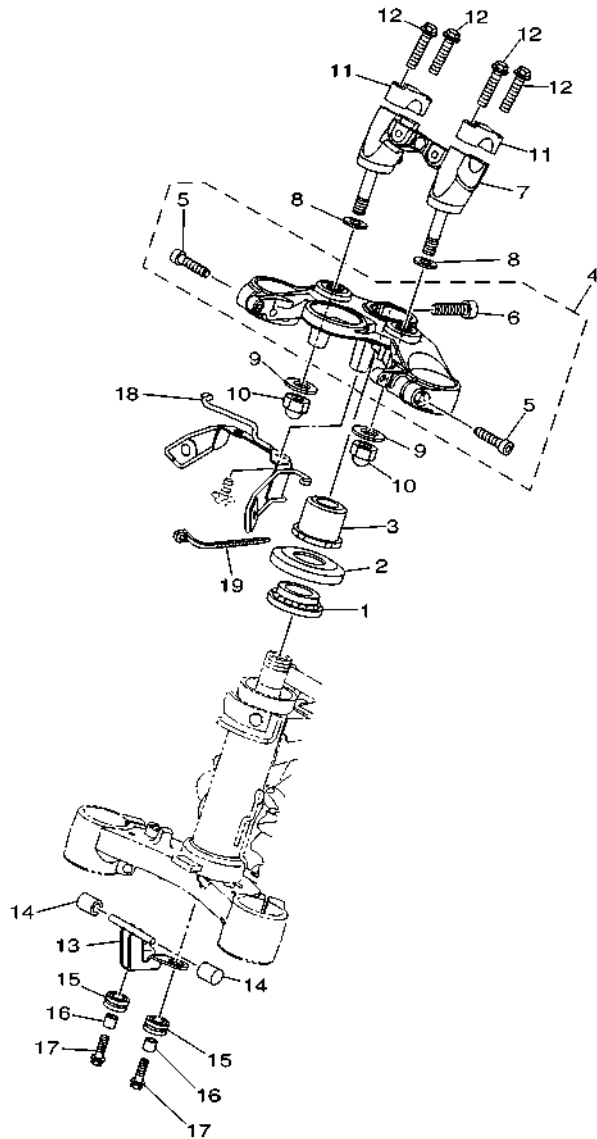

B4C9300-U240

REF. NO.	PART NO.	DESCRIPTION	B7S2	REMARKS
1	93399-99931	BEARING	1	
2	1W1-23416-00	COVER, BALL RACE 2	1	
3	1WS-23357-00	NUT	1	
4	BC6-23430-00	HANDLE CROWN COMP.	1	
5	91314-08030	.BOLT, HEXAGON SOCKET HEAD	2	
6	91314-10035	.BOLT, HEXAGON SOCKET HEAD	1	
7	1WS-23442-00-P0	HOLDER, HANDLE LOWER	1	MBL2
8	92902-10200	WASHER	2	
9	90201-10043	WASHER, PLATE	2	
10	90176-10003	NUT, CROWN	2	
11	1E6-23441-10-P0	HOLDER, HANDLE UPPER	2	MBL2
12	95022-08035	BOLT, FLANGE	4	
13	B4C-2334G-00	BRACKET 1	1	
14	1WS-84527-00	DAMPER	2	
15	3C3-83513-00	DAMPER	2	
16	90387-06026	COLLAR	2	
17	95D37-06025	BOLT, FLANGE DEEP RECESS	2	
18	B4C-2334H-00	BRACKET 2	1	
19	90464-25004	CLAMP	1	(101.0x7.0)

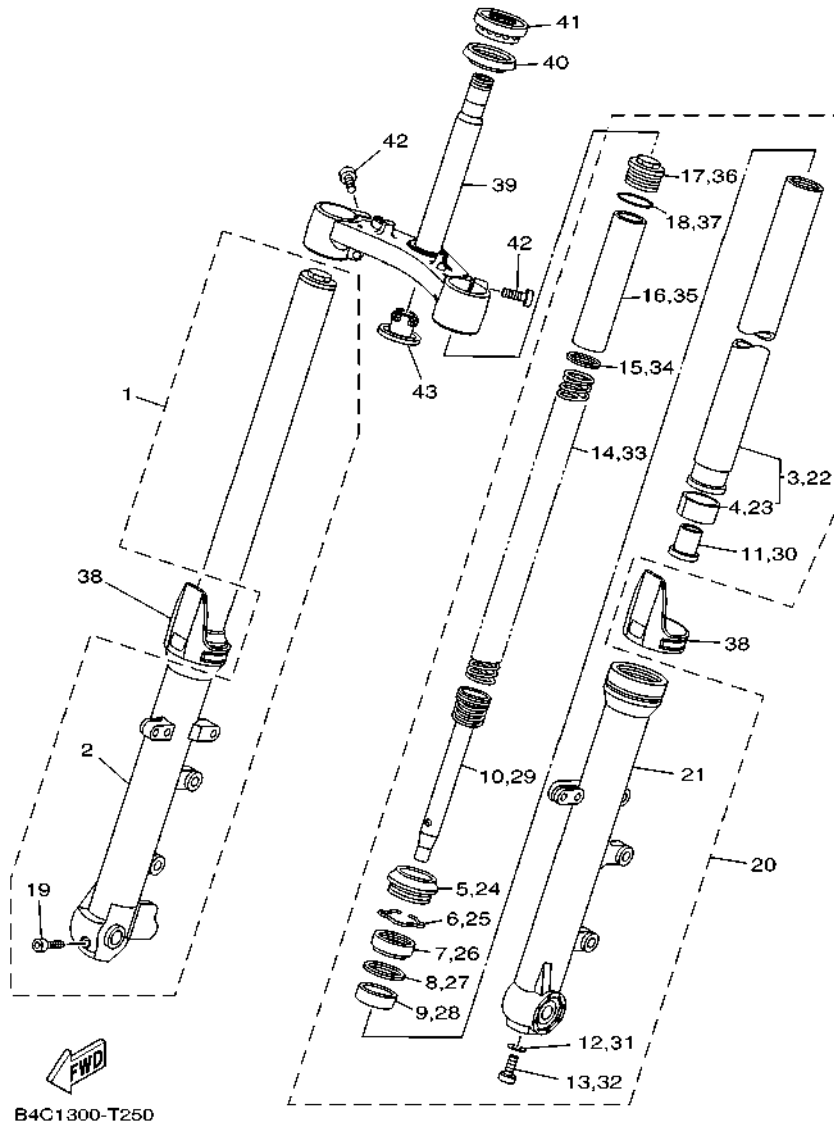

FIG. 25 FRONT FORK

REF. NO.	PART NO.	DESCRIPTION	B7S2				REMARKS
1	B4C-23103-00	FRONT FORK ASSY (R.H)	1				
2	1XB-23136-01	.TUBE, OUTER 2	1				
3	1WS-23110-00	.INNER TUBE COMP.1	1				
4	5BN-23171-00	..PISTON, FRONT FORK	1				
5	4EB-23144-00	.SEAL, DUST	1				
6	26H-23156-00	.RING, SNAP	1				
7	4EB-23145-01	.OIL SEAL	1				
8	36Y-23146-10	.WASHER, OIL SEAL	1				
9	4FM-23125-40	.METAL, SLIDE 1	1				
10	B4C-23170-00	.CYLINDER COMP., FRONT FORK	1				
11	4YR-23173-00	.SPINDLE, TAPER	1				(KYB)
12	509-23158-L0	.GASKET	1				(KYB)
13	278-23181-50	.BOLT, HEXAGON SOCKET HEAD	1				
14	BC6-23141-00	.SPRING, FRONT FORK	1				
15	3EN-23149-50	.WASHER, SPRING UPPER	1				
16	3FW-23118-00	.SPACER	1				
17	1D0-23111-00	.BOLT, CAP	1				
18	43F-23188-10	.O-RING	1				
19	91314-08040	.BOLT, HEXAGON SOCKET HEAD	1				
20	B4C-23102-00	FRONT FORK ASSY (L.H)	1				
21	1WS-23126-01	.TUBE, OUTER (L.H)	1				
22	1WS-23110-00	.INNER TUBE COMP.1	1				
23	5BN-23171-00	..PISTON, FRONT FORK	1				
24	4EB-23144-00	.SEAL, DUST	1				
25	26H-23156-00	.RING, SNAP	1				
26	4EB-23145-01	.OIL SEAL	1				
27	36Y-23146-10	.WASHER, OIL SEAL	1				

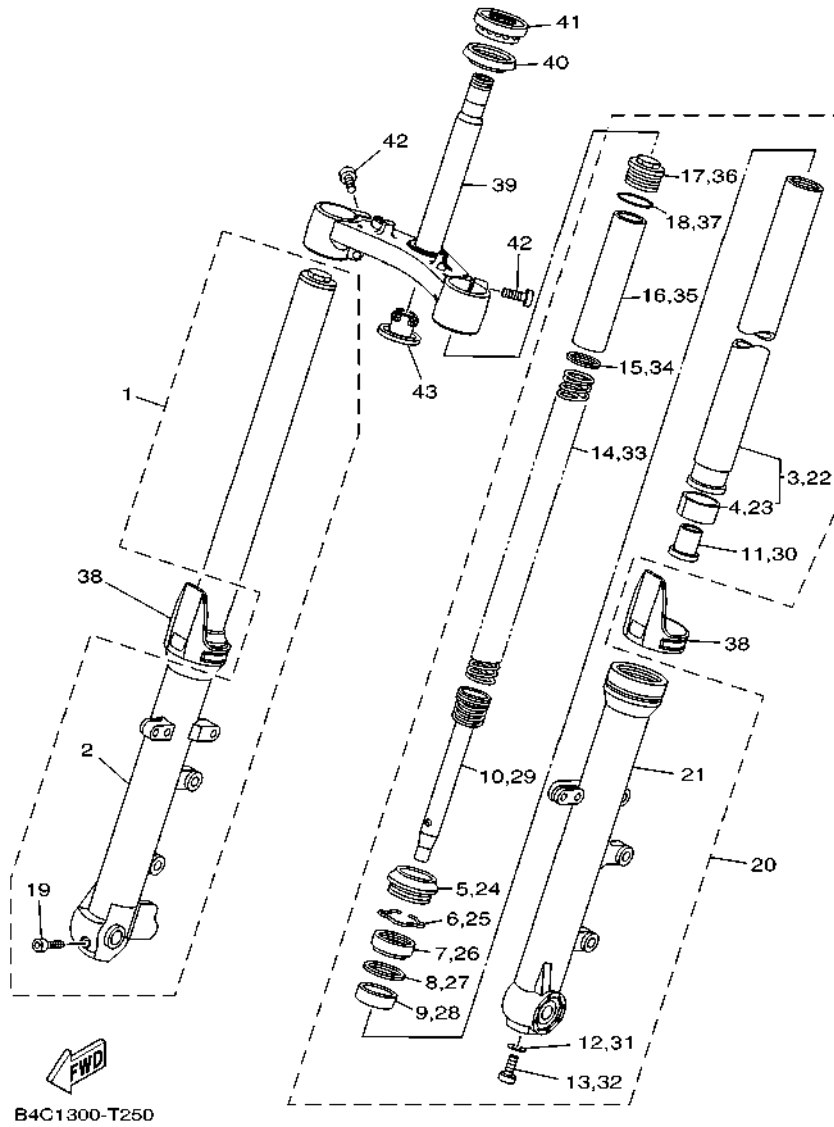
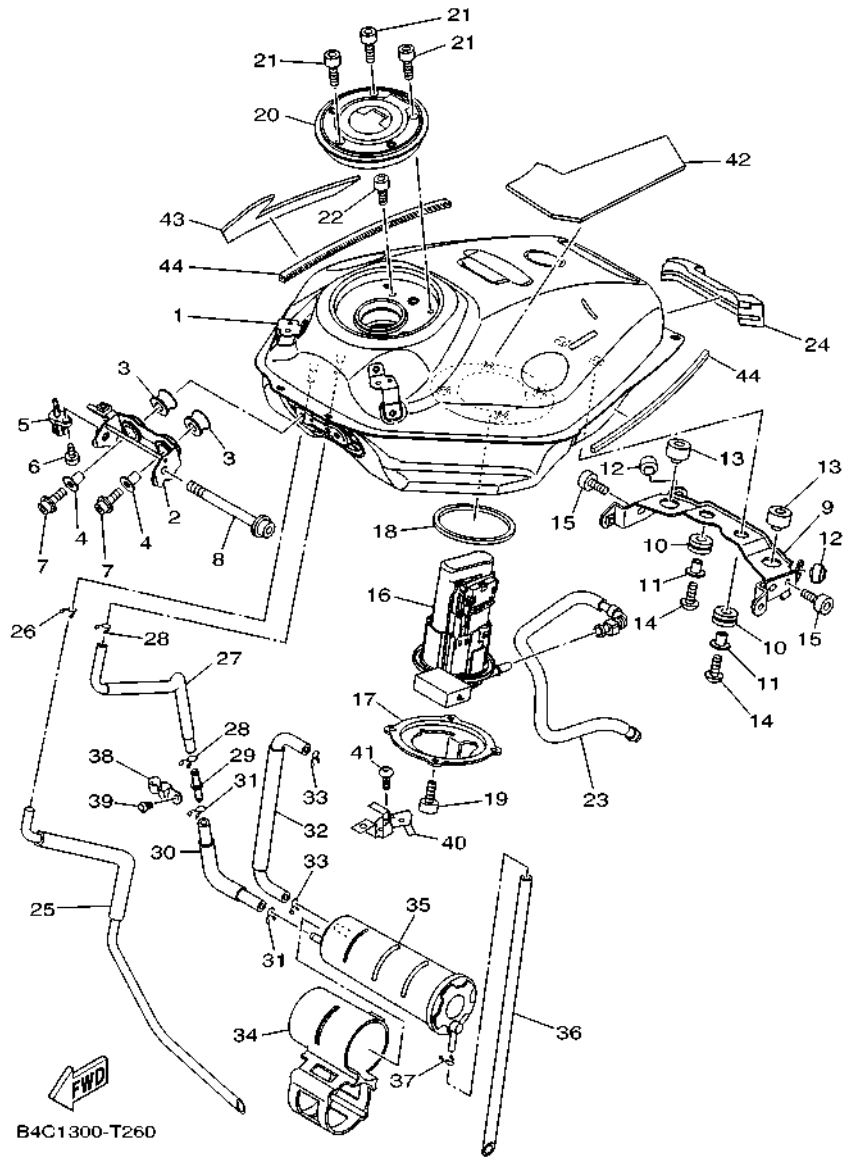

FIG. 25 FRONT FORK

REF. NO.	PART NO.	DESCRIPTION	B7S2	REMARKS
28	4FM-23125-40	.METAL, SLIDE 1	1	
29	B4C-23170-00	.CYLINDER COMP., FRONT FORK	1	
30	4YR-23173-00	.SPINDLE, TAPER	1	(KYB)
31	509-23158-L0	.GASKET	1	(KYB)
32	278-23181-50	.BOLT, HEXAGON SOCKET HEAD	1	
33	BC6-23141-00	.SPRING, FRONT FORK	1	
34	3EN-23149-50	.WASHER, SPRING UPPER	1	
35	3FW-23118-00	.SPACER	1	
36	1D0-23111-00	.BOLT, CAP	1	
37	43F-23188-10	.O-RING	1	
38	1WS-2331G-00	COVER	2	
39	B34-23340-00	UNDER BRACKET COMP.	1	
40	3FV-23462-00	SEAL, STEERING	1	
41	93399-99932	BEARING	1	
42	91314-08030	BOLT, HEXAGON SOCKET HEAD	4	
43	4KM-23123-01	COVER, UNDER 1	1	

FIG. 26 FUEL TANK



REF. NO.	PART NO.	DESCRIPTION	B7S2			REMARKS
1	B4C-24110-00	FUEL TANK COMP.	1			
2	1WS-2412Y-00	BRACKET, TANK FITTING	1			
3	3D7-24339-00	GROMMET	2			
4	90387-06136	COLLAR	2			
5	5YU-85886-00	SENSOR, AIR TEMPERATURE	1			
6	98502-05012	SCREW, PAN HEAD	1			
7	90110-06172	BOLT, HEXAGON SOCKET HEAD	2			
8	95817-08100	BOLT, FLANGE	1			
9	B4C-2413Y-00	BRACKET, TANK FITTING	1			
10	90480-16003	GROMMET	2			
11	90387-06287	COLLAR	2			
12	5UY-27114-00	STOPPER, MAIN STAND	2			
13	278-27114-00	STOPPER, MAIN STAND	2			
14	90111-06084	BOLT, HEX. SOCKET BUTTON	2			
15	91312-06014	BOLT, HEXAGON SOCKET HEAD	4			
16	1WS-13907-00	FUEL PUMP COMP.	1			
17	1WS-24491-00	BRACKET, FUEL PUMP	1			
18	1RC-24486-00	O-RING	1			
19	91312-05010	BOLT, HEXAGON SOCKET HEAD	4			
20	1WS-24602-00	CAP ASSY	1			
21	90110-05112	BOLT, HEXAGON SOCKET HEAD	3			
22	91317-05010	BOLT, HEX. SOCKET HEAD	1			
23	1WS-13971-00	PIPE, FUEL 1	1			
24	B4C-2411J-00	DAMPER, SIDE COVER	1			
25	2RC-24318-00	PIPE, OVERFLOW	1			
26	90467-090A2	CLIP	1			
27	B2G-24321-00	PIPE 10	1			

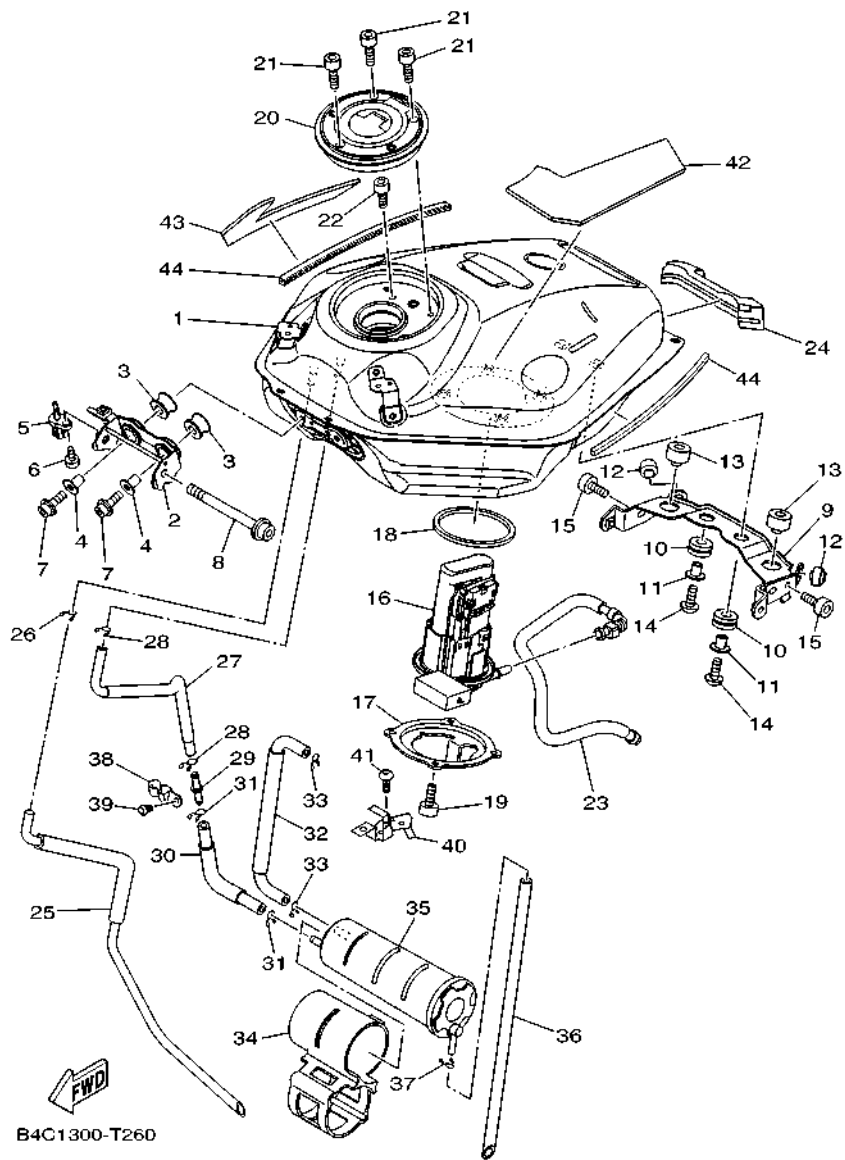
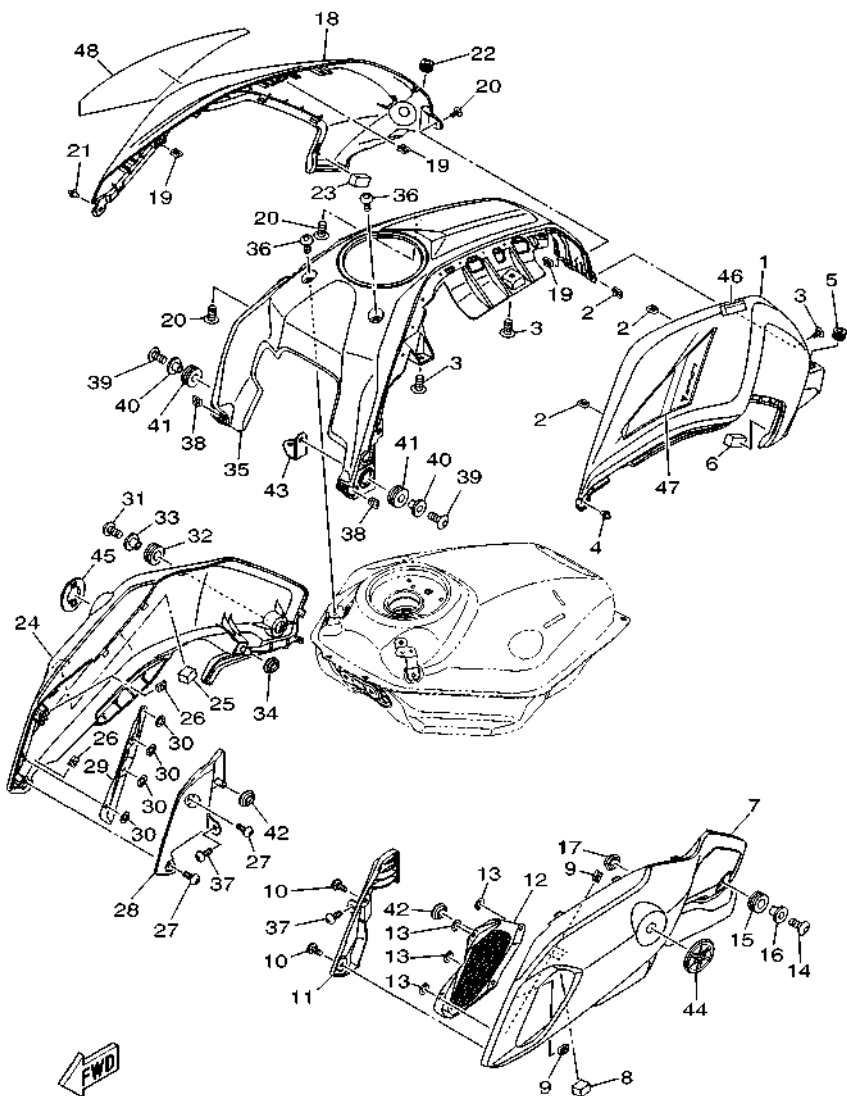

FIG. 26 FUEL TANK

REF. NO.	PART NO.	DESCRIPTION	B7S2	REMARKS
28	90467-090A2	CLIP	2	
29	4XY-14568-00	JOINT	1	
30	B2G-24322-00	PIPE 11	1	
31	90467-090A2	CLIP	2	
32	2RC-24323-00	PIPE 12	1	
33	90467-090A2	CLIP	2	
34	2RC-24182-00	DAMPER, LOCATING 2	1	
35	2RC-24170-00	CANISTER ASSY	1	
36	2RC-24324-00	PIPE 13	1	
37	90467-090A2	CLIP	1	
38	1WS-24135-00	CLAMP 1	1	
39	92017-06010	BOLT, BUTTON HEAD	1	
40	2RC-2419F-00	BRACKET, CANISTOR	1	
41	90111-06119	BOLT,HEX. SOCKET BUTTON	1	
42	1WS-2414H-00	DAMPER, PLATE 1	1	
43	1WS-2414J-00	DAMPER, PLATE 2	1	
44	3D7-24188-00	MOLD, FUEL TANK	2	

FIG. 27 FUEL TANK 2



B7S1440-U270

REF. NO.	PART NO.	DESCRIPTION	B7S2	REMARKS
1	B4C-24129-00-P0	COVER, SIDE 1	1	UR FOR DPBMC
	B4C-24129-00-P4	COVER, SIDE 1	1	UR FOR MLNM4
2	90183-05076	NUT, SPRING	3	
3	90111-05003	BOLT,HEX. SOCKET BUTTON	3	
4	90269-06008	RIVET	1	
5	90480-12314	GROMMET	1	
6	2C0-2414R-00	DAMPER, PLATE 6	1	
7	B4C-2137W-01	SCOOP, AIR 1	1	
8	B4C-24181-00	DAMPER, LOCATING 1	1	
9	90183-05076	NUT, SPRING	2	
10	90111-05003	BOLT,HEX. SOCKET BUTTON	2	
11	B4C-2836K-00	PANEL, INNER 1	1	
12	B4C-2837N-00	GRILL, AIR INTAKE 1	1	
13	90183-05M02	NUT, SPRING	4	
14	90109-06317	BOLT	1	
15	90480-17007	GROMMET	1	
16	90387-10107	COLLAR	1	
17	90480-01558	GROMMET	1	
18	B4C-24139-00-P0	COVER, SIDE 2	1	UR FOR DPBMC
	B4C-24139-00-P4	COVER, SIDE 2	1	UR FOR MLNM4
19	90183-05076	NUT, SPRING	3	
20	90111-05003	BOLT,HEX. SOCKET BUTTON	3	
21	90269-06008	RIVET	1	
22	90480-12314	GROMMET	1	
23	2C0-2414R-00	DAMPER, PLATE 6	1	
24	B4C-2137X-01	SCOOP, AIR 2	1	
25	B4C-24182-00	DAMPER, LOCATING 2	1	

FIG. 27 FUEL TANK 2

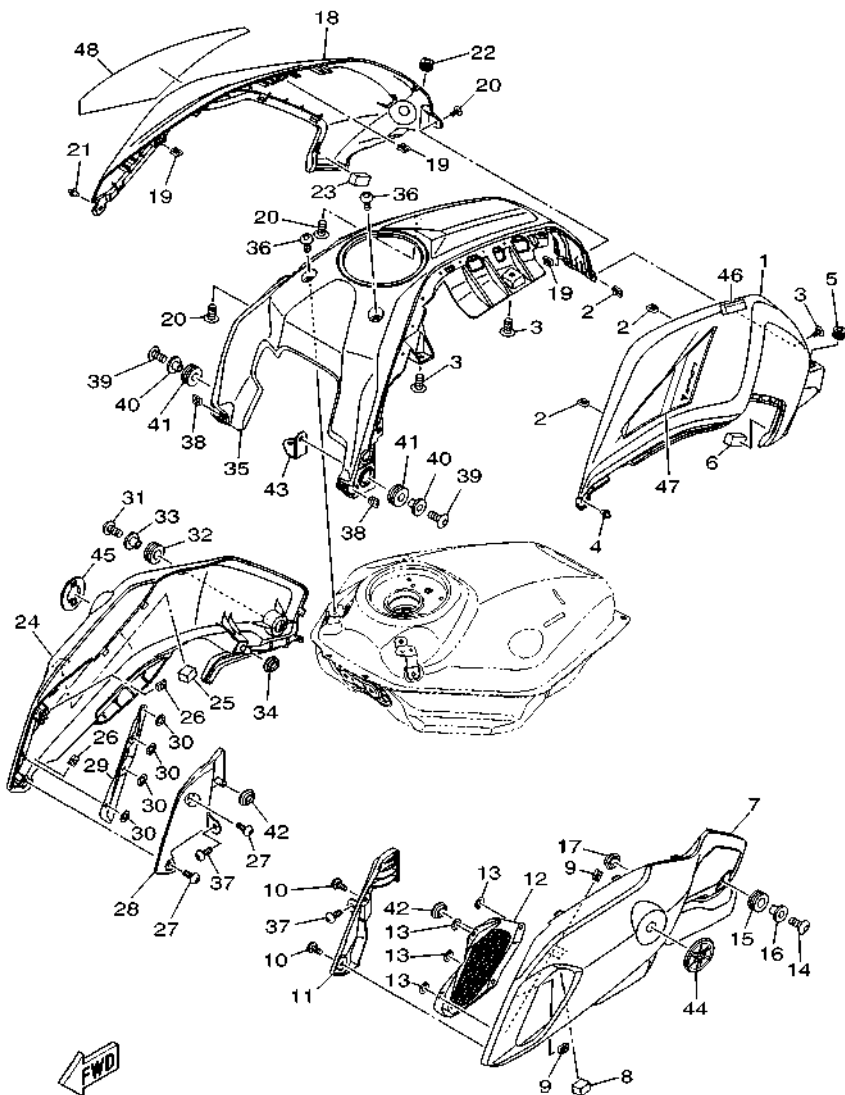

B7S1440-U270

REF. NO.	PART NO.	DESCRIPTION	B7S2	REMARKS
26	90183-05076	NUT, SPRING	2	
27	90111-05003	BOLT,HEX. SOCKET BUTTON	2	
28	B4C-2836L-00	PANEL, INNER 2	1	
29	B4C-2837R-00	GRILL, AIR INTAKE 2	1	
30	90183-05M02	NUT, SPRING	4	
31	90109-06317	BOLT	1	
32	90480-17007	GROMMET	1	
33	90387-10107	COLLAR	1	
34	90480-01558	GROMMET	1	
35	B4C-2464E-00	COVER, CAP	1	
36	90111-05011	BOLT,HEX. SOCKET BUTTON	2	
37	90111-05002	BOLT,HEX. SOCKET BUTTON	2	
38	90183-05076	NUT, SPRING	2	
39	90111-06084	BOLT,HEX. SOCKET BUTTON	2	
40	90387-07042	COLLAR	2	
41	90480-14452	GROMMET	2	
42	90480-01559	GROMMET	2	
43	1WS-2463E-00	BRACKET, CAP	1	
44	1RC-2413B-01	EMBLEM	1	
45	1RC-2413B-01	EMBLEM	1	
46	1XC-21568-00	LABEL, WARNING	1	
47	B4C-217F1-00	GRAPHIC, 1	1	UR FOR DPBMC
	B4C-217F1-40	GRAPHIC, 1	1	UR FOR MLNM4
48	B4C-217F2-00	GRAPHIC, 2	1	UR FOR DPBMC
	B4C-217F2-40	GRAPHIC, 2	1	UR FOR MLNM4

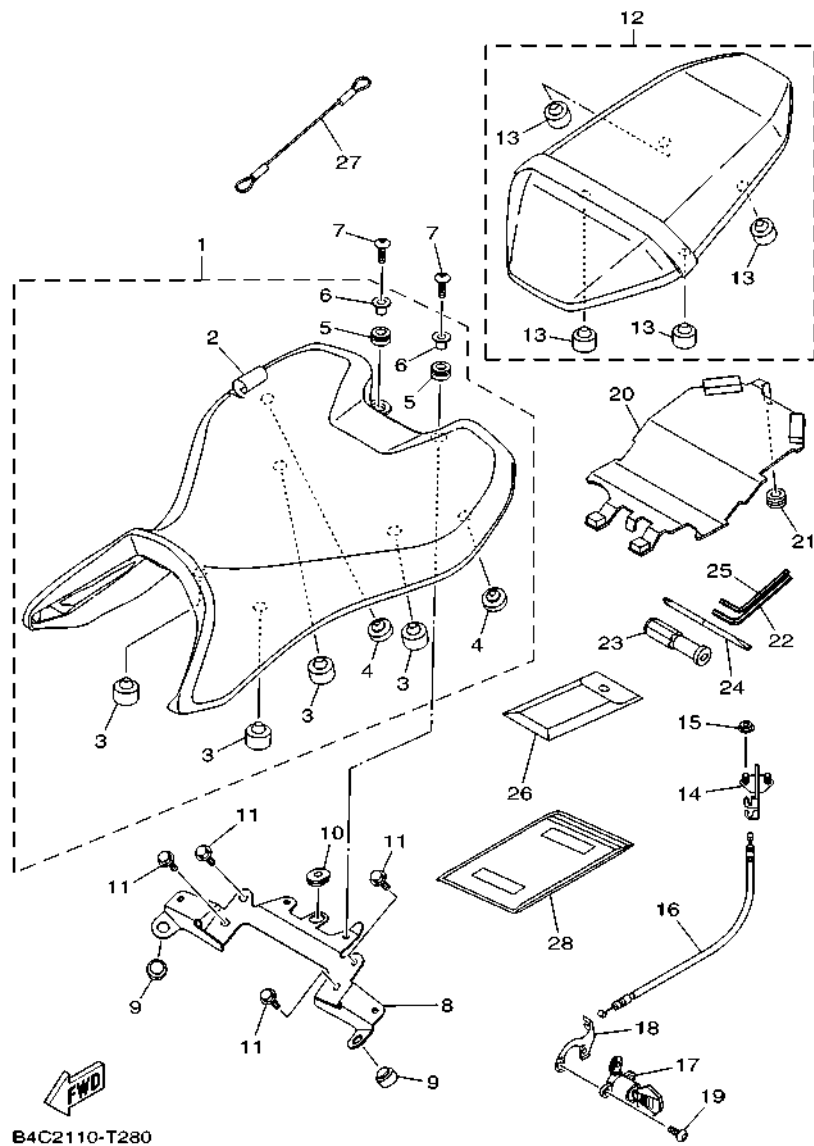

B4C2110-T280

FIG. 28 SEAT

REF. NO.	PART NO.	DESCRIPTION	B7S2	REMARKS
1	B4C-24710-00	SINGLE SEAT ASSY	1	
2	B4C-2470F-00	.SEAT COVER COMP.	1	
3	371-27114-00	.STOPPER, MAIN STAND	4	
4	22W-24741-00	.PAD, SEAT	2	
5	90480-14604	.GROMMET	2	
6	90387-07391	.COLLAR	2	
7	90111-06139	BOLT,HEX. SOCKET BUTTON	2	
8	B4C-21131-00	BRACKET	1	
9	157-27114-00	STOPPER, MAIN STAND	2	
10	90480-01558	GROMMET	1	
11	95D32-06010	BOLT, FLANGE DEEP RECESS	4	
12	B4C-24750-00	TANDEM SEAT ASSY	1	
13	278-27114-00	.STOPPER, MAIN STAND	4	
14	1WS-24780-00	SEAT LOCK ASSY	1	
15	95702-06500	NUT, FLANGE	2	
16	1WS-2478E-00	CABLE, SEAT LOCK	1	
17	2TV-W2470-00	ROTOR SET	1	
18	23P-2117K-00	STAY, LOCK	1	
19	90149-06030	SCREW	2	
20	B4C-2477A-00	SEAT COVER ASSY	1	
21	90480-12237	GROMMET	1	
22	14B-28164-00	WRENCH, HEXAGON 8	1	
23	2H7-28151-00	GRIP, DRIVER	1	
24	137-28152-00	DRIVER	1	
25	23P-28164-00	WRENCH, HEXAGON 8	1	
26	B4C-28100-00	TOOL KIT	1	
27	2S3-21398-00	HANGER, HELMET	1	

FIG. 29 FRONT WHEEL

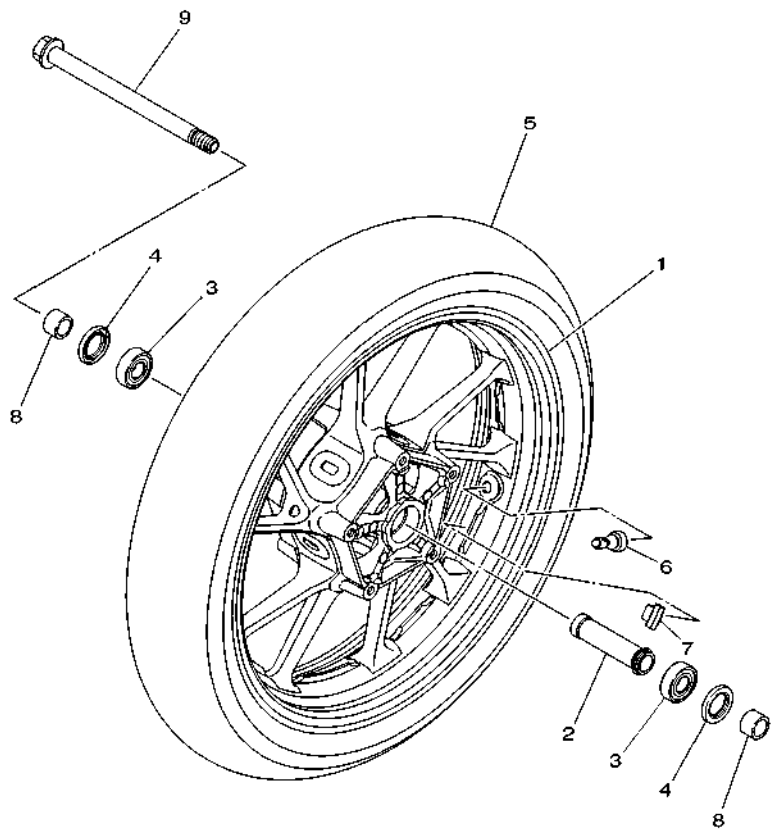

1WSG300-N290

REF. NO.	PART NO.	DESCRIPTION	B7S2	REMARKS
1	1XB-25168-00-P0	CAST WHEEL, FRONT	1	DPBM15 FOR DPBMC
	1XB-25168-00-P5	CAST WHEEL, FRONT	1	VYRS6 FOR MLNM4
2	2PP-25117-00	SPACER, BEARING	1	
3	93306-20352	BEARING	2	
4	93102-25017	OIL SEAL	2	
5	94112-17121	TIRE (120/70ZR17M/C 58W)	1	BRIDGESTONE
6	93900-00030	VALVE, RIM (TR412)	1	TAIHEIYO
7	5MT-25398-00	BALANCER, WHEEL (10G)	1	UN
	5MT-25398-10	BALANCER, WHEEL (20G)	1	UN
	5MT-25398-20	BALANCER, WHEEL (30G)	1	UN
8	90387-17017	COLLAR	2	
9	3MA-25181-10	AXLE, WHEEL	1	

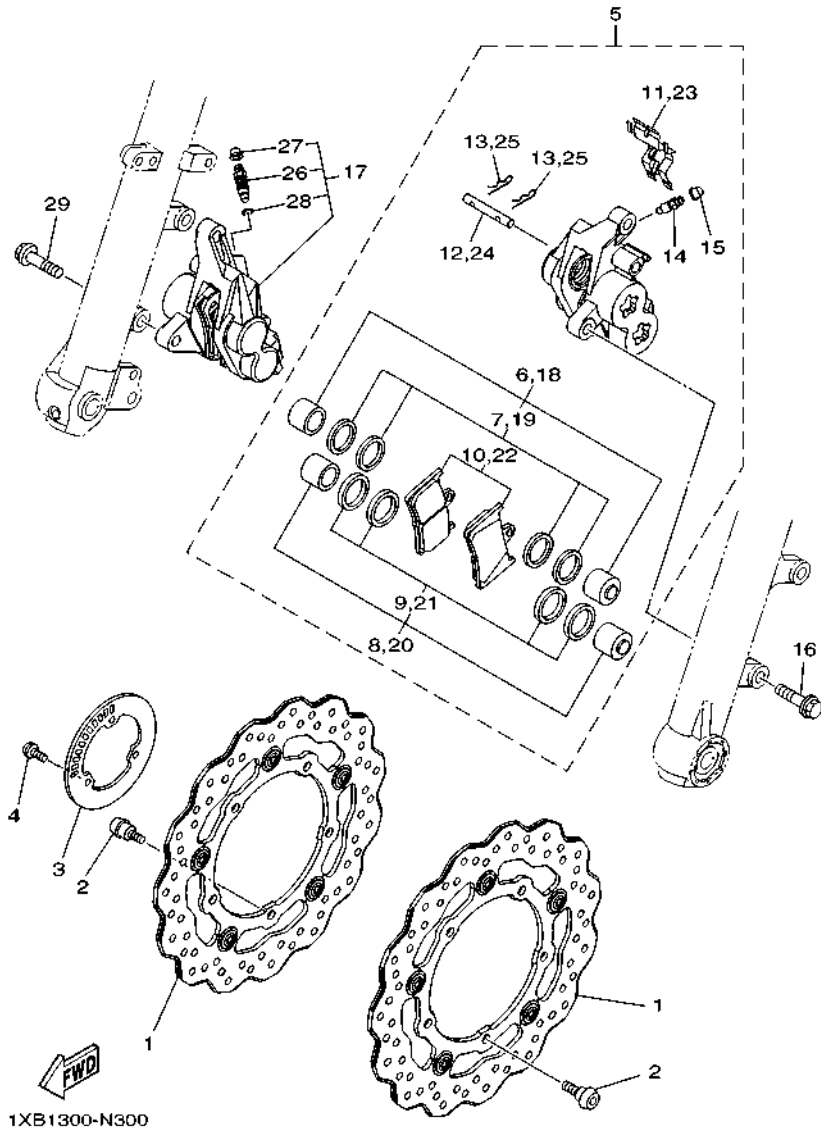

1XB1300-N300

FIG. 30 FRONT BRAKE CALIPER

REF. NO.	PART NO.	DESCRIPTION	B7S2				REMARKS
1	1WS-2581T-00	DISK BRAKE ASSY	2				
2	90109-064G6	BOLT	10				
3	2DR-2517G-00	ROTOR, SENSOR	1				
4	90149-05029	SCREW	3				
5	1WS-2580T-00	CALIPER ASSY (LEFT)	1				
6	4SV-25802-10	.PISTON ASSY, CALIPER	1				
7	3GM-25803-10	..CALIPER SEAL KIT	1				
8	4SV-25802-00	.PISTON ASSY, CALIPER	1				
9	3MA-25803-10	..CALIPER SEAL KIT	1				
10	1WS-25805-00	.BRAKE PAD KIT	1				
11	13S-25919-00	.SUPPORT, PAD	1				
12	4SV-25924-00	.PIN, PAD	1				
13	3GM-25925-00	.CLIP	2				
14	1J3-25824-00	.SCREW, BLEED	1				
15	306-25825-01	.CAP	1				
16	90105-10638	BOLT, FLANGE	2				
17	1XB-2580U-00	CALIPER ASSY (RIGHT)	1				
18	4SV-25802-10	.PISTON ASSY, CALIPER	1				
19	3GM-25803-10	..CALIPER SEAL KIT	1				
20	4SV-25802-00	.PISTON ASSY, CALIPER	1				
21	3MA-25803-10	..CALIPER SEAL KIT	1				
22	1WS-25805-00	.BRAKE PAD KIT	1				
23	13S-25919-00	.SUPPORT, PAD	1				
24	4SV-25924-00	.PIN, PAD	1				
25	3GM-25925-00	.CLIP	2				
26	5VS-25824-00	.SCREW, BLEED	1				
27	306-25825-01	.CAP	1				

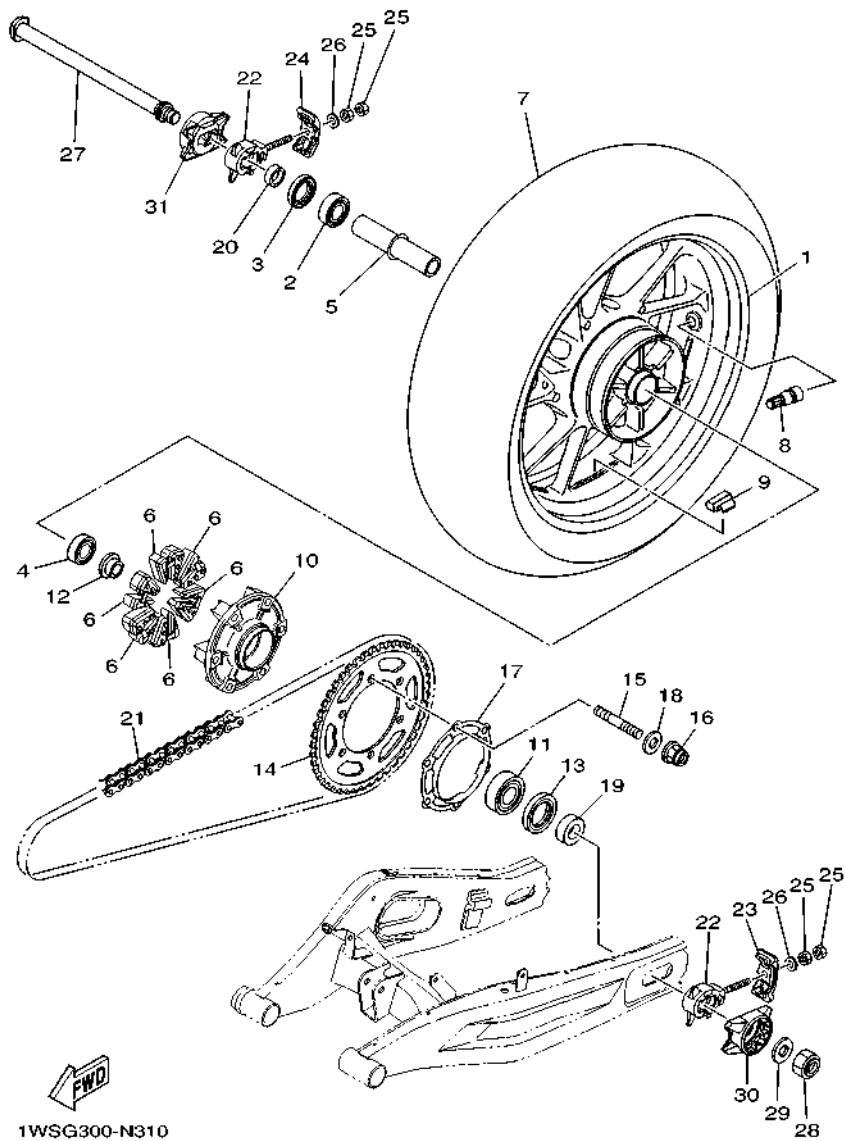

FIG. 31 REAR WHEEL

REF. NO.	PART NO.	DESCRIPTION	B7S2	REMARKS
1	2DR-25338-00-P0	CAST WHEEL, REAR	1	DPBM15 FOR DPBMC
	2DR-25338-00-P6	CAST WHEEL, REAR	1	VYRS6 FOR MLNM4
2	93306-20480	BEARING	1	
3	93102-28022	OIL SEAL	1	
4	93306-00416	BEARING	1	
5	2PP-25317-00	SPACER, BEARING	1	
6	5SL-25364-00	DAMPER	6	
7	94118-17080	TIRE (180/55ZR17 M/C 73W)	1	BRIDGESTONE
8	93900-00030	VALVE, RIM (TR412)	1	TAIHEIYO
9	5MT-25398-00	BALANCER, WHEEL (10G)	1	UR
	5MT-25398-10	BALANCER, WHEEL (20G)	1	UR
	5MT-25398-20	BALANCER, WHEEL (30G)	1	UR
10	5JJ-25366-00	CLUTCH, HUB	1	
11	93306-205B5	BEARING	1	
12	1RC-25383-00	COLLAR, WHEEL	1	
13	93106-40013	OIL SEAL	1	
14	1WS-25443-00	SPROCKET, DRIVEN (43T)	1	
15	90116-10048	BOLT, STUD	6	
16	95602-10200	NUT, S/L FLANGE	6	
17	1WS-2537W-00	BRACKET 1	1	
18	90201-10045	WASHER, PLATE	6	
19	90387-20036	COLLAR	1	
20	90387-20035	COLLAR	1	
21	94582-40108	CHAIN (DID 525VZ-108LE)	1	
22	1WS-25388-00	PULLER, CHAIN 1	2	
23	1WS-22174-00	END 1	1	
24	1WS-22175-00	END 1	1	

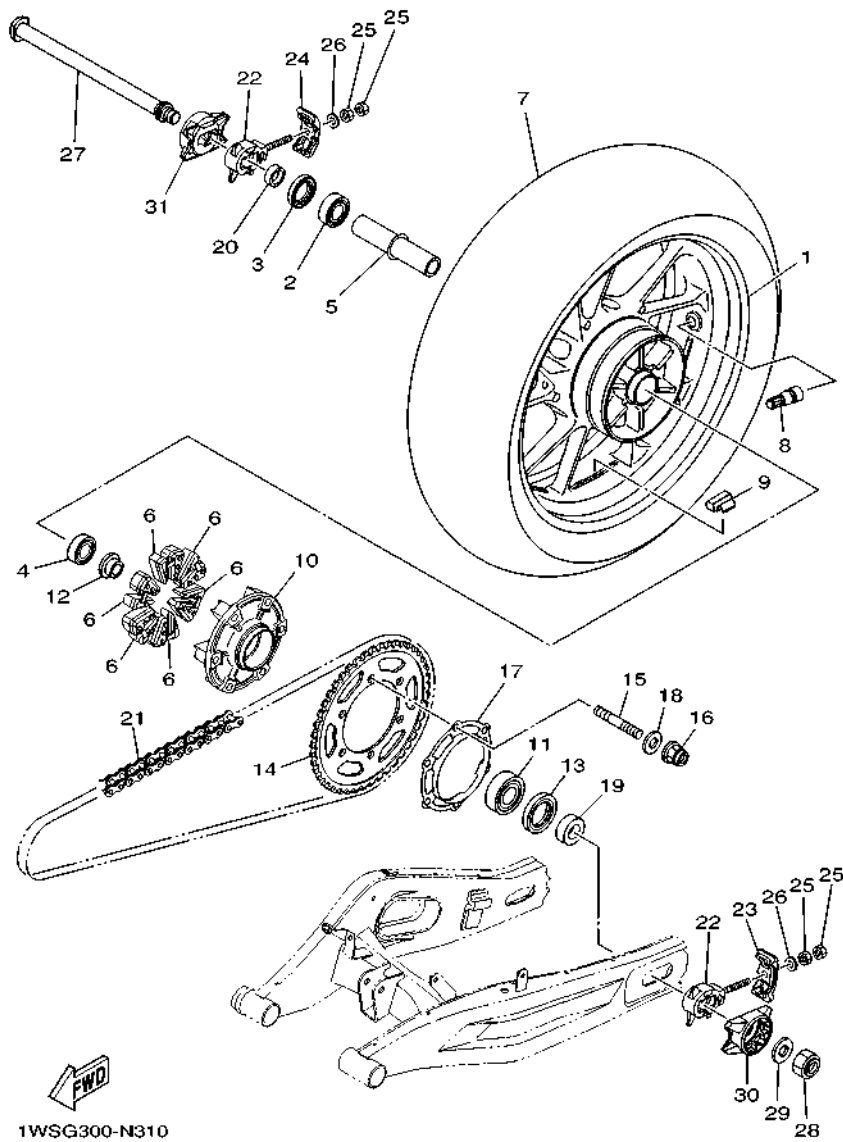
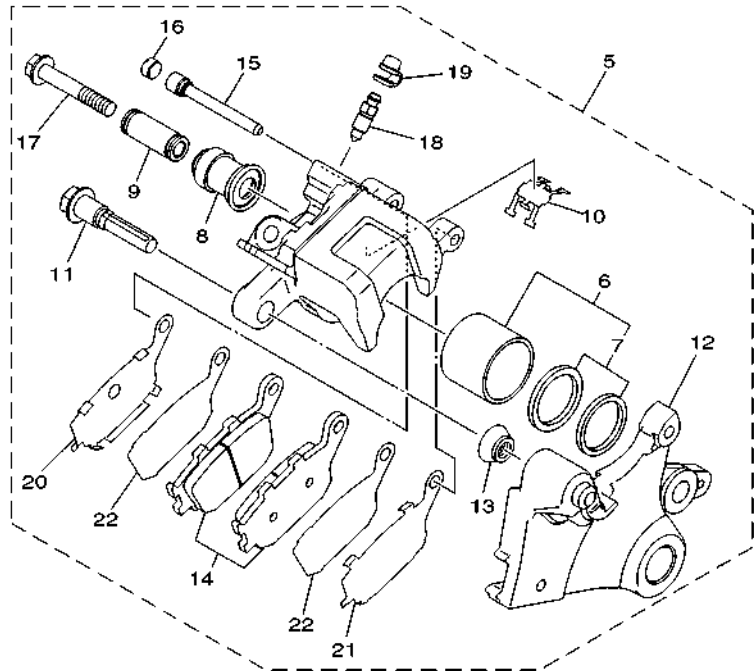

FIG. 31 REAR WHEEL

REF. NO.	PART NO.	DESCRIPTION	B7S2	REMARKS
25	95302-08600	NUT, HEXAGON	4	
26	92902-08600	WASHER, PLATE	2	
27	4FN-22141-00	SHAFT, PIVOT	1	
28	90185-18009	NUT, SELF-LOCKING	1	
29	90201-18021	WASHER, PLATE	1	
30	1WS-2538D-00	COVER, REAR AXLE 1	1	
31	1WS-2538N-00	COVER, REAR AXLE 2	1	



 1XB1300-N321

FIG. 32 REAR BRAKE CALIPER

REF. NO.	PART NO.	DESCRIPTION	B7S2	REMARKS
1	1WS-2582W-00	DISK, REAR BRAKE 2	1	
2	90109-08045	BOLT	5	
3	2DR-2517G-00	ROTOR, SENSOR	1	
4	90149-05029	SCREW	3	
5	2DR-2580W-00	CALIPER ASSY, REAR 2	1	
6	5SL-25802-00	.PISTON ASSY, CALIPER	1	
7	5SL-25803-00	.CALIPER SEAL KIT	1	
8	5SL-25917-00	.BOOT, CALIPER	1	
9	5SL-25838-00	.SLEEVE, CALIPER	1	
10	5SL-25919-00	.SUPPORT, PAD	1	
11	5SL-25914-00	.PIN, SLIDE	1	
12	2DR-25921-50	.BRACKET, SUPPORT	1	
13	3JD-25917-00	.BOOT, CALIPER	1	
14	5VX-25806-00	.BRAKE PAD KIT 2	1	
15	8CR-25924-00	.PIN, PAD	1	
16	5DH-25916-00	.PLUG	1	
17	1RC-25926-00	.BOLT	1	
18	8CR-25824-00	.SCREW, BLEED	1	
19	1UY-25825-51	.CAP	1	
20	5SL-25827-00	.SHIM, CALIPER	1	
21	5SL-25827-10	.SHIM, CALIPER	1	
22	5SL-25828-01	.SHIM, CALIPER	2	

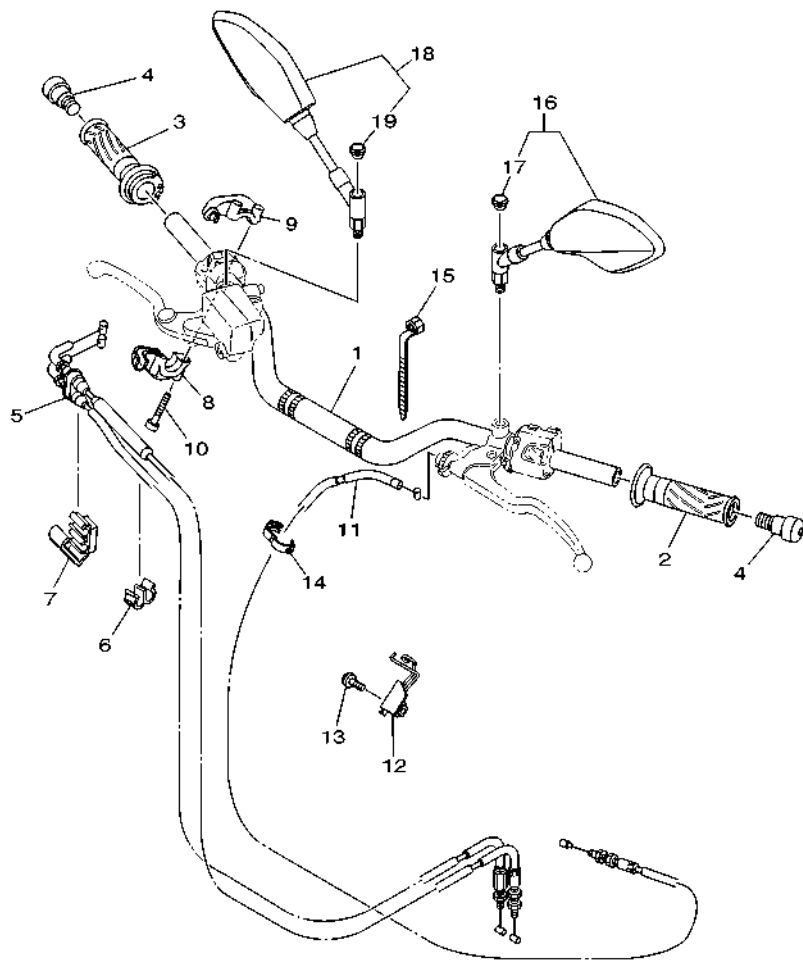

B7S1440-U330

FIG. 33 STEERING HANDLE & CABLE

REF. NO.	PART NO.	DESCRIPTION	B7S2	REMARKS
1	B4C-26111-00	HANDLEBAR	1	
2	4YR-26241-02	GRIP (LEFT)	1	
3	1WS-26240-00	GRIP ASSY	1	
4	5RU-26246-00	END, GRIP	2	
5	1WS-26301-00	THROTTLE CABLE ASSY	1	
6	90468-15139	CLIP	1	
7	39P-2627E-00	CLAMP, WIRE	1	
8	1WS-26281-00	CAP, GRIP UPPER	1	
9	1WS-26282-00	CAP, GRIP LOWER	1	
10	91317-05040	BOLT, HEX. SOCKET HEAD	2	
11	1WS-26335-00	CABLE, CLUTCH	1	
12	1WS-2612E-00	BRACKET	1	
13	90111-06101	BOLT, HEX. SOCKET BUTTON	1	
14	90464-14010	CLAMP	1	
15	90464-25004	CLAMP	1	(101.0x7.0)
16	B5C-26280-00	REAR VIEW MIRROR ASSY (LEFT)	1	
17	23P-26133-00	.CAP	1	
18	B5C-26290-00	REAR VIEW MIRROR ASSY (RIGHT)	1	
19	23P-26133-00	.CAP	1	

FIG. 34 FRONT MASTER CYLINDER

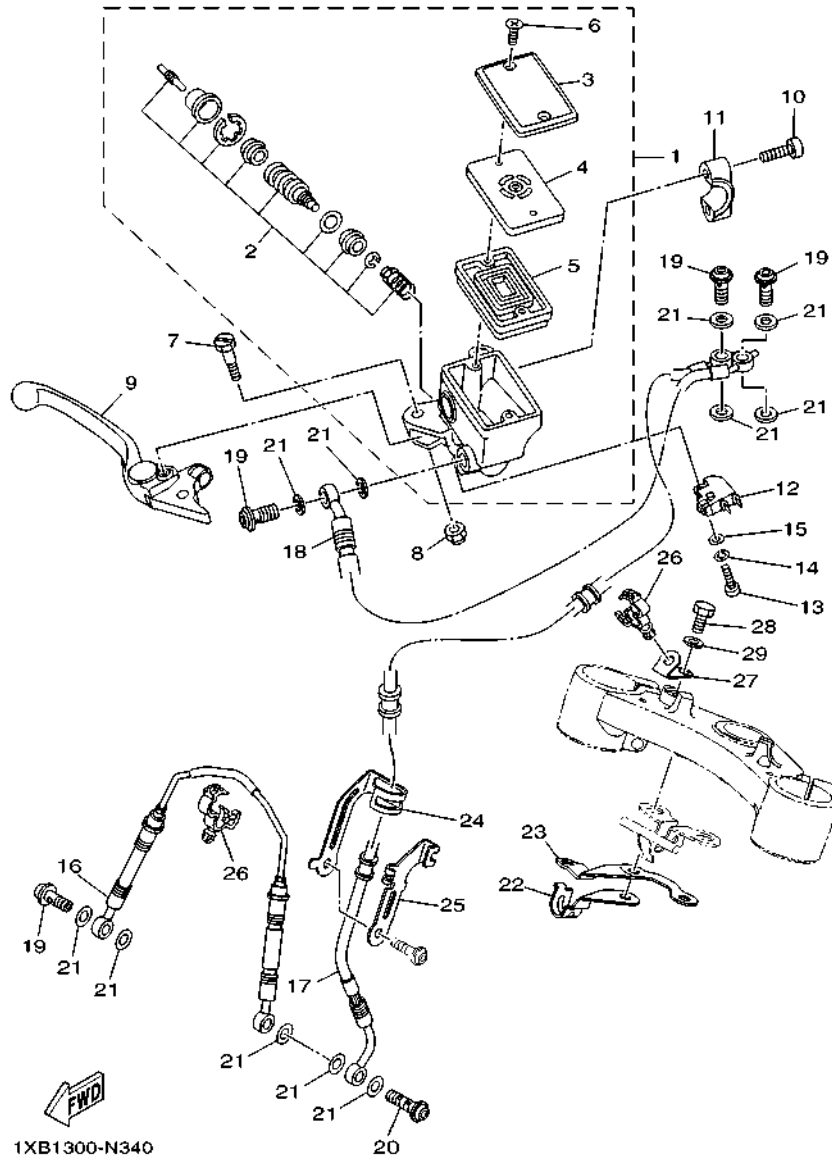

REF. NO.	PART NO.	DESCRIPTION	B7S2				REMARKS
1	1XB-2580A-00	MASTER CYLINDER SUB ASSY 2	1				
2	1WS-25807-00	.CYLINDER KIT, MASTER	1				
3	5VS-25852-00	.CAP, RESERVOIR	1				
4	5VS-25855-00	.BUSH,DIAPHRAGM	1				
5	20S-25854-00	.DIAPHRAGM, RESERVOIR	1				
6	5VS-2589H-00	.SCREW	2				
7	5VS-2589F-00	BOLT, LEVER	1				
8	95617-06100	NUT, SELF-LOCKING	1				
9	5VS-83922-00	LEVER 2	1				
10	5VS-26332-00	BOLT	2				
11	5VS-25867-00	BRACKET, MASTER CYLINDER	1				
12	1HP-83980-01	FRONT STOP SWITCH ASSY	1				
13	98502-04012	SCREW, PAN HEAD	1				
14	92902-04100	WASHER, SPRING	1				
15	92902-04600	WASHER, PLATE	1				
16	1XB-25872-00	HOSE, BRAKE 1	1				
17	BU2-2584A-00	BRAKE HOSE ASSY	1				
18	BU2-2584B-00	HOSE, BRAKE	1				
19	90401-10172	BOLT, UNION	4				
20	90401-10042	BOLT, UNION	1				
21	90430-10005	GASKET	11				
22	1XB-25875-00	HOLDER, BRAKE HOSE 1	1				
23	1WS-2587A-00	HOLDER, BRAKE HOSE	1				
24	1XB-25876-00	HOLDER, BRAKE HOSE 2	1				
25	1XB-25886-00	HOLDER, BRAKE HOSE	1				
26	90464-18002	CLAMP	2				
27	1WS-26296-00	BRACKET	1				

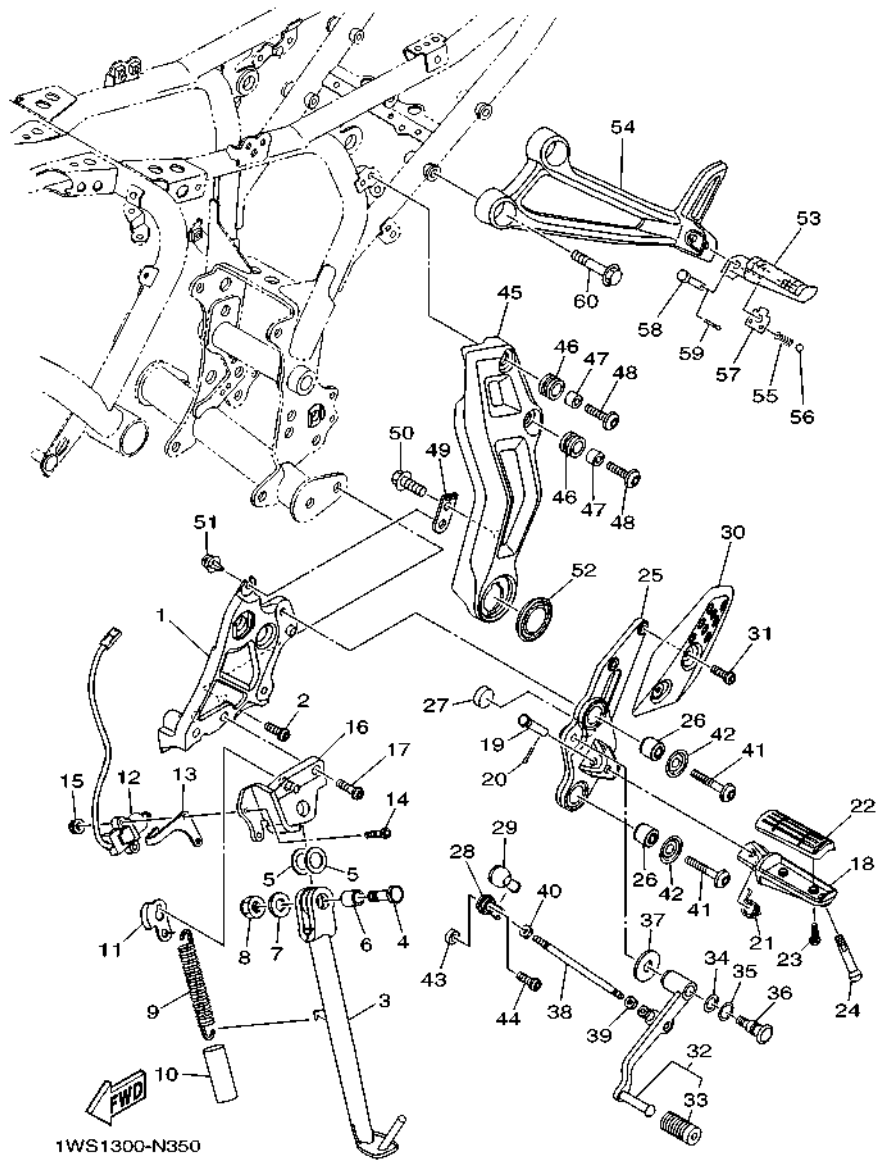

FIG. 35 STAND & FOOTREST

REF. NO.	PART NO.	DESCRIPTION	B7S2	REMARKS
1	B34-274A3-00	BRACKET, ADAPTER 1	1	
2	90111-10006	BOLT,HEX. SOCKET BUTTON	2	
3	1WS-27311-00	STAND, SIDE	1	
4	90101-10025	BOLT	1	
5	90201-17018	WASHER, PLATE	2	
6	90387-10050	COLLAR	1	
7	90201-10035	WASHER, PLATE	1	
8	90185-10023	NUT, SELF-LOCKING	1	
9	90506-23018	SPRING, TENSION	1	
10	5VX-27351-00	GUIDE, SIDE STAND	1	
11	5VX-27315-00	LINK, SIDE STAND	1	
12	1WS-82566-00	SWITCH, SIDE STAND	1	
13	1WS-2419A-00	HOLDER	1	
14	90110-05071	BOLT, HEXAGON SOCKET HEAD	2	
15	95602-05200	NUT, SELF-LOCKING	2	
16	1WS-27321-00	BRACKET, SIDE STAND	1	
17	90111-10059	BOLT,HEX. SOCKET BUTTON	2	
18	1WS-27451-00	FOOTREST	1	
19	91701-08040	PIN	1	
20	91402-25015	PIN, COTTER	1	
21	90508-18056	SPRING, TORSION	1	
22	3YX-27413-00	COVER, FOOTREST	1	
23	90157-05025	SCREW, PAN HEAD	2	
24	90109-086F8	BOLT	1	
25	1WS-27442-10	BRACKET 2	1	
26	36Y-27414-00	DAMPER, FOOTREST	2	
27	5VX-27114-00	STOPPER, MAIN STAND	1	

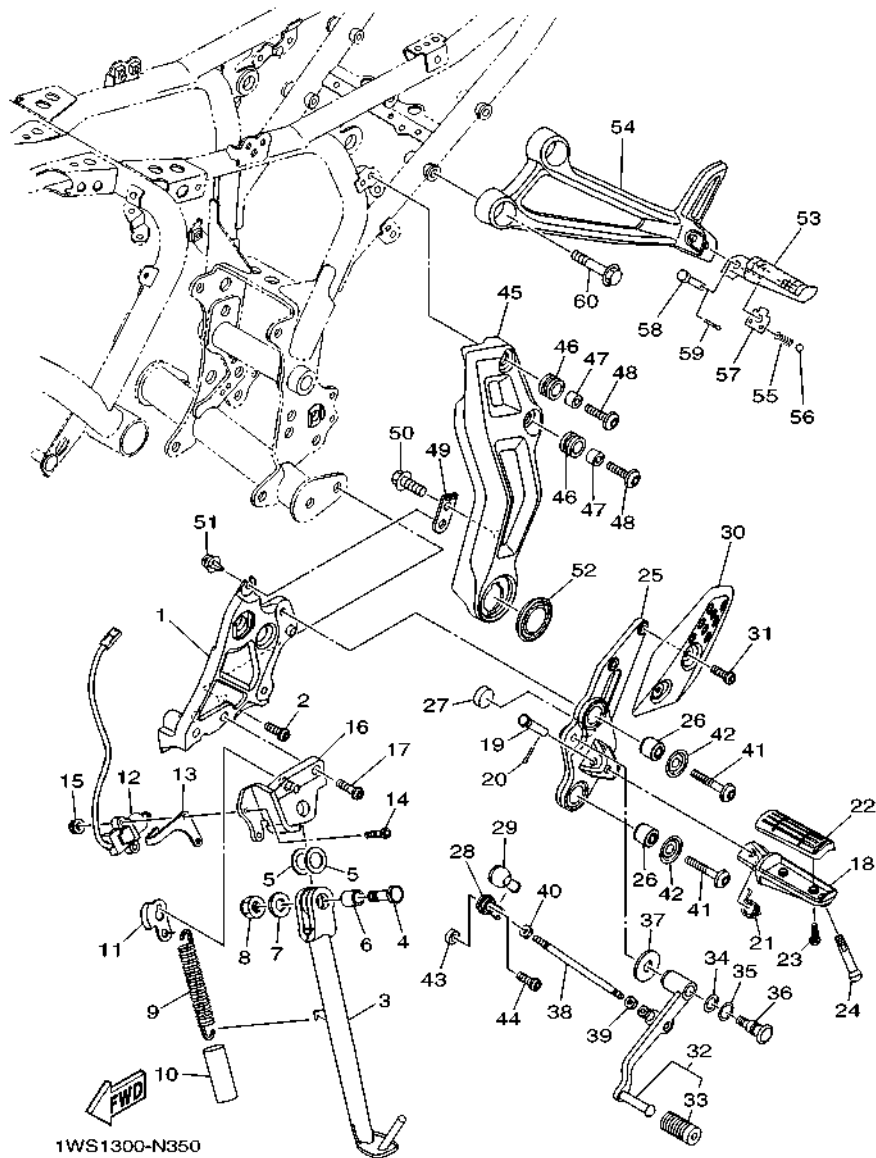
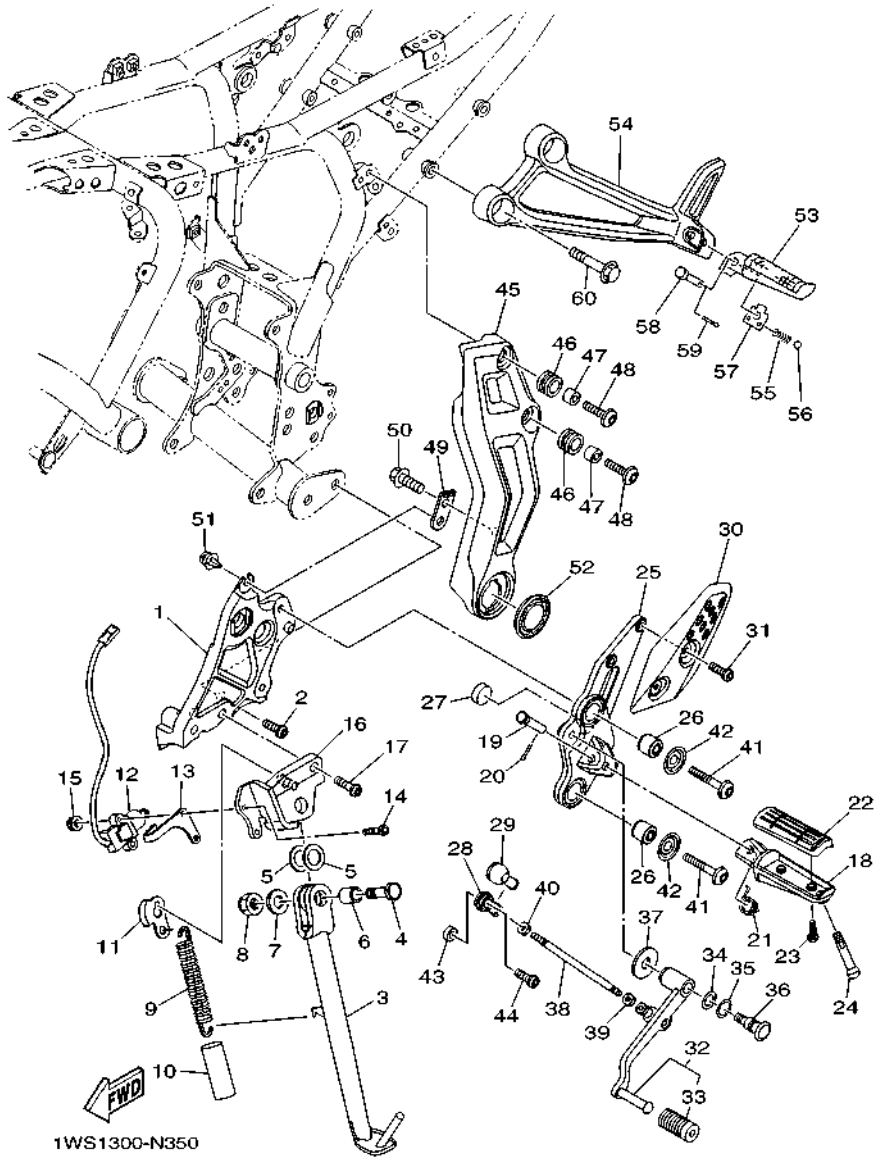

FIG. 35 STAND & FOOTREST

REF. NO.	PART NO.	DESCRIPTION	B7S2	REMARKS
28	5VX-18116-00	JOINT, ROD 1	1	
29	5VX-18154-00	COVER, DUST	1	
30	1WS-27445-10	PLATE 1	1	
31	92014-06012	BOLT, BUTTON HEAD	2	
32	B34-18110-00	SHIFT PEDAL ASSY	1	
33	1WS-18113-00	.COVER, SHIFT PEDAL	1	
34	90201-12051	WASHER, PLATE	1	
35	90206-12074	WASHER, WAVE	1	
36	4BP-27434-01	BOLT	1	
37	90201-08053	WASHER, PLATE	1	
38	B4C-18115-00	ROD, SHIFT	1	
39	90170-06026	NUT	1	
40	95314-06700	NUT	1	
41	90110-08071	BOLT, HEXAGON SOCKET HEAD	2	
42	90209-08295	WASHER	2	
43	90387-06372	COLLAR	1	
44	92012-06020	BOLT, BUTTON HEAD	1	
45	1WS-27453-10	COVER 1	1	
46	90480-14003	GROMMET	2	
47	90387-06057	COLLAR	2	
48	90149-06105	SCREW	2	
49	1WS-27425-00	BRACKET, FOOTREST 2	1	
50	95D02-06010	BOLT, FLANGE DEEP RECESS	1	
51	90269-08008	RIVET	1	
52	1WS-27475-00-P0	CAP 1	1	MBL2
53	3VR-27431-02	FOOTREST, REAR 1	1	
54	1WS-2741L-01	BRACKET 4	1	



1WS1300-N350

FIG. 35 STAND & FOOTREST

REF. NO.	PART NO.	DESCRIPTION	B7S2	REMARKS
55	90501-12743	SPRING, COMPRESSION	1	
56	93501-04011	BALL	1	
57	5VX-27437-00	WASHER, SPECIAL	1	
58	91702-08040	PIN, CLEVIS	1	
59	91401-25015	PIN, COTTER	1	
60	90110-08231	BOLT, HEXAGON SOCKET HEAD	2	

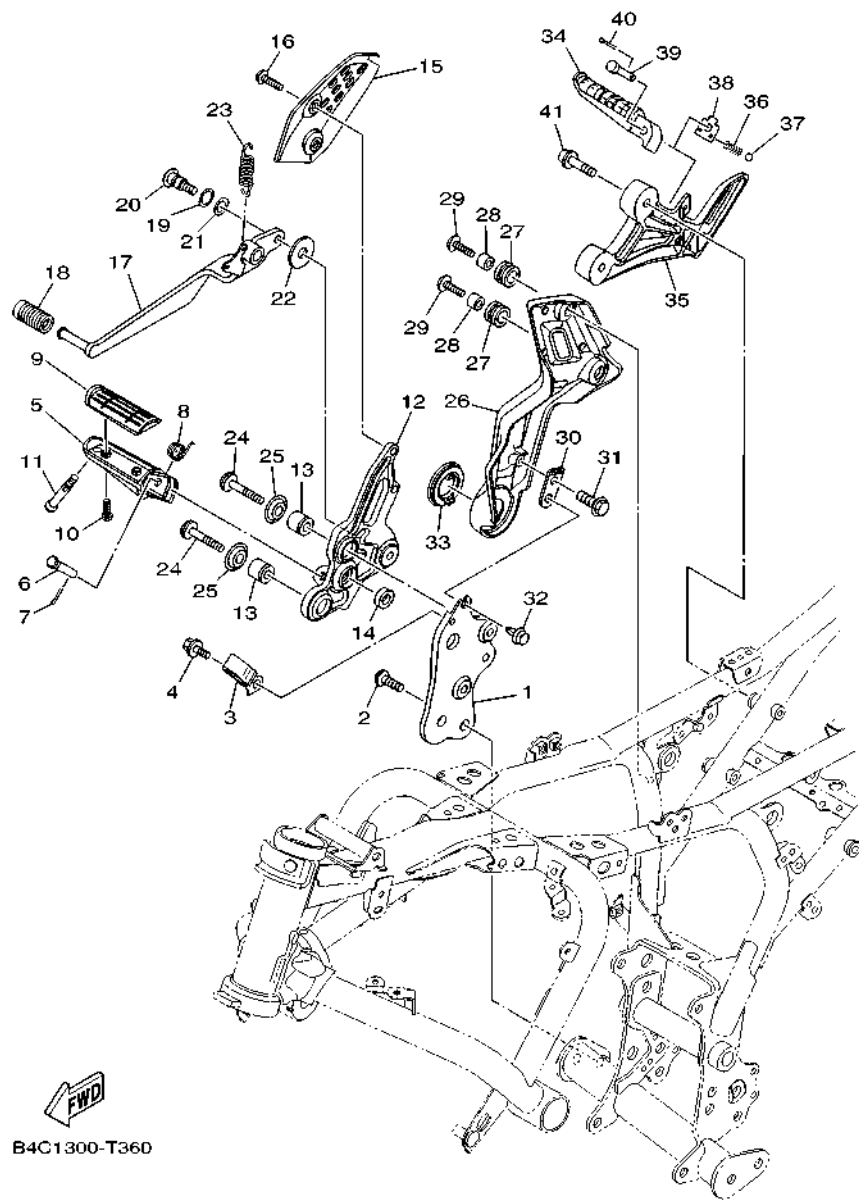
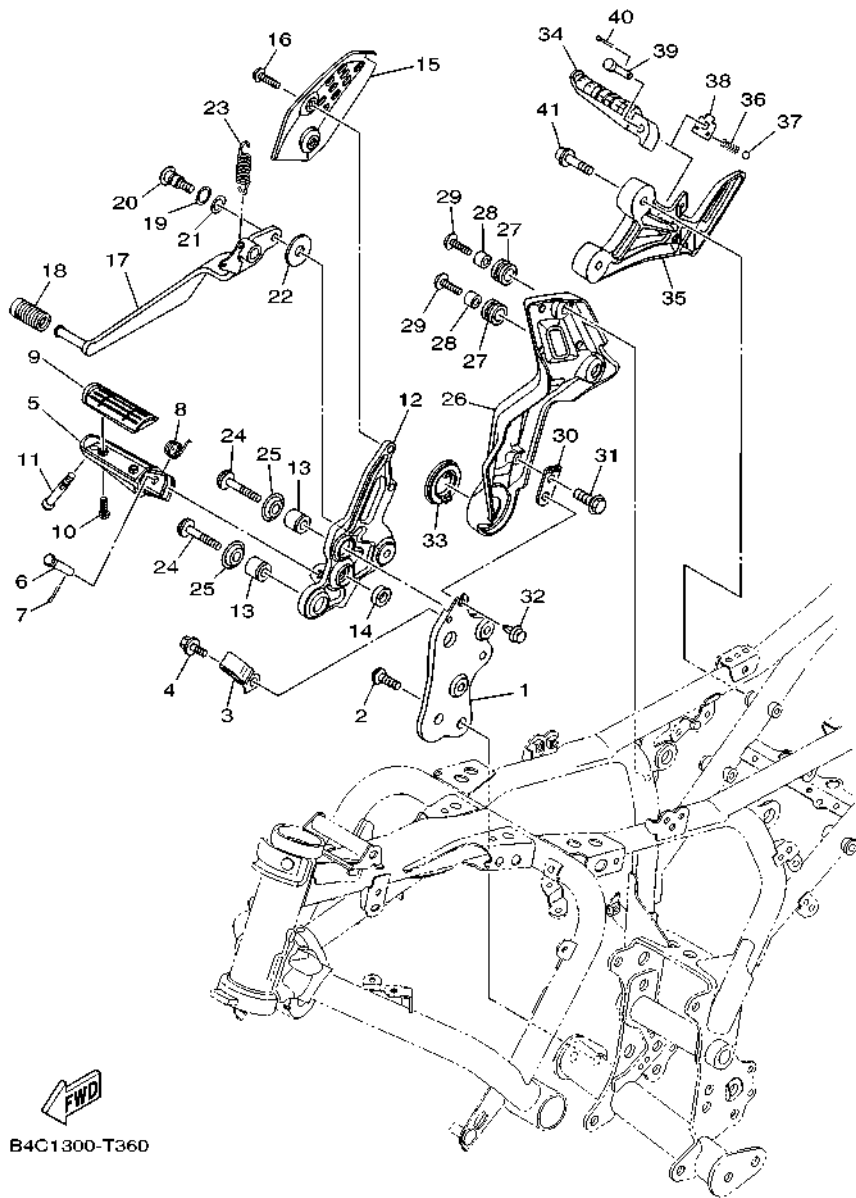

FIG. 36 STAND & FOOTREST 2

REF. NO.	PART NO.	DESCRIPTION	B7S2				REMARKS
1	B34-274A4-00	BRACKET,ADAPTER 2	1				
2	90111-10006	BOLT,HEX. SOCKET BUTTON	2				
3	90465-08045	CLAMP	1				
4	95022-06010	BOLT, FLANGE	1				
5	1WS-27461-00	FOOTREST	1				
6	91701-08040	PIN	1				
7	91402-25015	PIN, COTTER	1				
8	90508-18056	SPRING, TORSION	1				
9	3YX-27413-00	COVER, FOOTREST	1				
10	90157-05025	SCREW, PAN HEAD	2				
11	90109-086F8	BOLT	1				
12	1WS-27443-10	BRACKET 3	1				
13	36Y-27414-00	DAMPER, FOOTREST	2				
14	5VX-27114-00	STOPPER, MAIN STAND	1				
15	1WS-27446-10	PLATE 2	1				
16	90111-08022	BOLT,HEX. SOCKET BUTTON	2				
17	B4C-27211-00	PEDAL, BRAKE	1				
18	1WS-18113-00	COVER, SHIFT PEDAL	1				
19	90206-12074	WASHER, WAVE	1				
20	4BP-27434-01	BOLT	1				
21	90201-12051	WASHER, PLATE	1				
22	90201-08053	WASHER, PLATE	1				
23	90506-23008	SPRING, TENSION	1				
24	90110-08071	BOLT, HEXAGON SOCKET HEAD	2				
25	90209-08295	WASHER	2				
26	1WS-27463-10	COVER 2	1				
27	90480-14003	GROMMET	2				



B4C1300-T360

FIG. 36 STAND & FOOTREST 2

REF. NO.	PART NO.	DESCRIPTION	B7S2	REMARKS
28	90387-06057	COLLAR	2	
29	90149-06105	SCREW	2	
30	1WS-27425-00	BRACKET, FOOTREST 2	1	
31	95D02-06010	BOLT, FLANGE DEEP RECESS	1	
32	90269-08008	RIVET	1	
33	1WS-27475-00-P0	CAP 1	1	MBL2
34	3VR-27441-02	FOOTREST, REAR 2	1	
35	1WS-2742L-01	BRACKET 5	1	
36	90501-12743	SPRING, COMPRESSION	1	
37	93501-04011	BALL	1	
38	5VX-27437-00	WASHER, SPECIAL	1	
39	91702-08040	PIN, CLEVIS	1	
40	91401-25015	PIN, COTTER	1	
41	90110-08231	BOLT, HEXAGON SOCKET HEAD	2	

FIG. 37 REAR MASTER CYLINDER

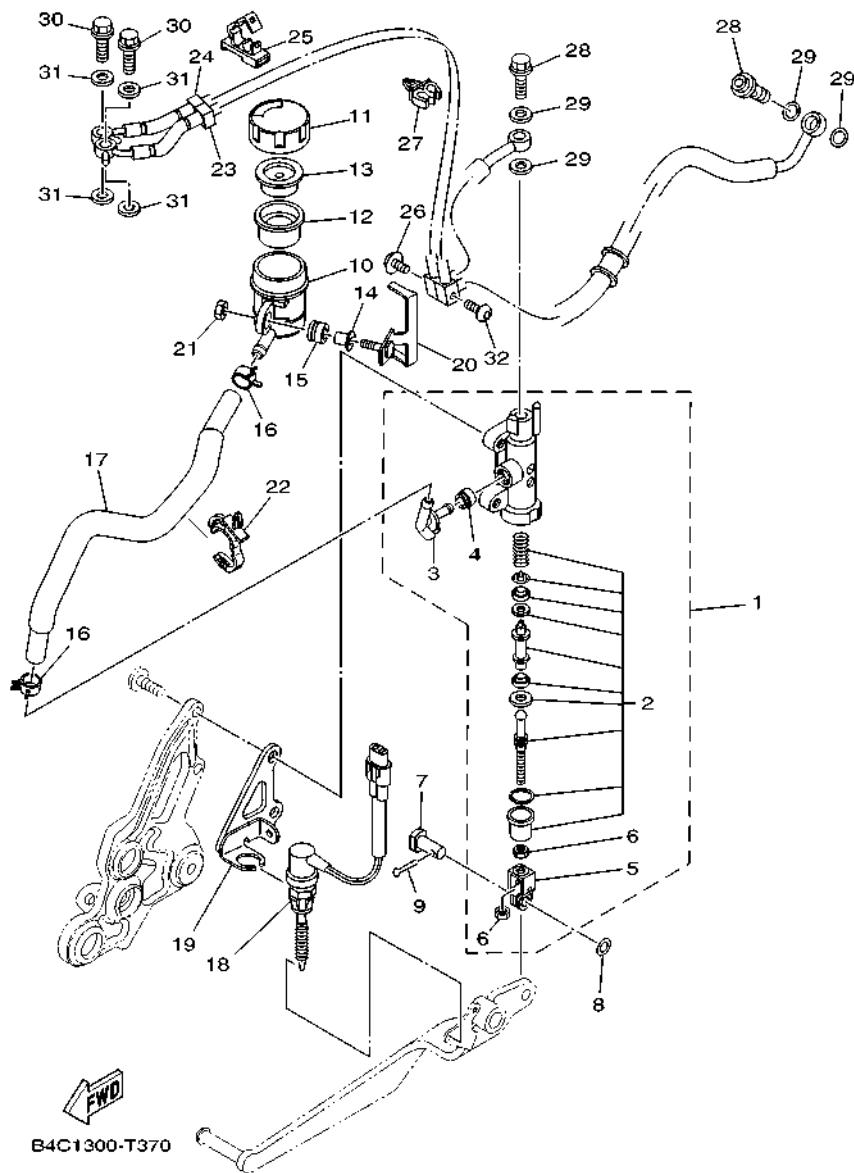

REF. NO.	PART NO.	DESCRIPTION	B7S2				REMARKS
1	4P5-2583V-00	RR. MASTER CYLINDER ASSY.	1				
2	5VX-W0042-51	.CYLINDER KIT, MASTER	1				
3	2D1-2582A-00	.JOINT	1				
4	4BP-2585F-01	.O-RING	1				
5	4BP-27222-02	.JOINT	1				
6	90170-08010	.NUT	2				
7	90240-08005	PIN, CLEVIS	1				
8	90201-08070	WASHER, PLATE	1				
9	91401-20012	PIN, COTTER	1				
10	14B-25894-00	TANK, RESERVOIR	1				
11	2C0-25852-00	CAP, RESERVOIR	1				
12	2VN-25854-00	DIAPHRAGM, RESERVOIR	1				
13	2VN-25855-00	BUSH,DIAPHRAGM	1				
14	90387-05028	COLLAR	1				
15	2C0-26326-00	GROMMET	1				
16	90467-11044	CLIP	2				
17	1WS-25895-00	HOSE, RESERVOIR	1				
18	B2G-82530-00	STOP SWITCH ASSY	1				
19	B4C-2144G-00	STAY, STOP SWITCH	1				
20	1WS-2582E-00	HOLDER, RESERVE TANK	1				
21	95707-05500	NUT, FLANGE	1				
22	90464-17008	CLAMP	1				
23	B4C-2584D-00	HOSE, BRAKE	1				
24	B4C-2584E-00	BRAKE HOSE ASSY 5	1				
25	90464-07014	CLAMP	1				
26	90105-06148	BOLT, FLANGE	1				
27	90464-07009	CLAMP	1				

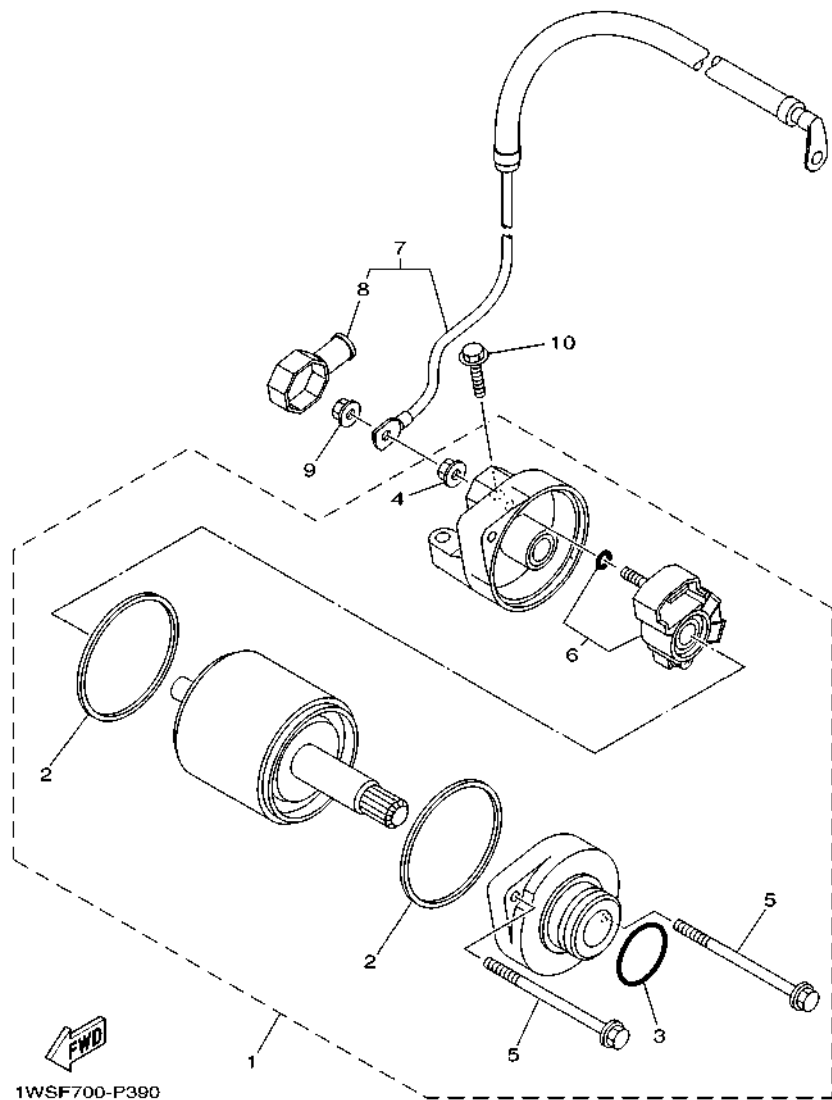
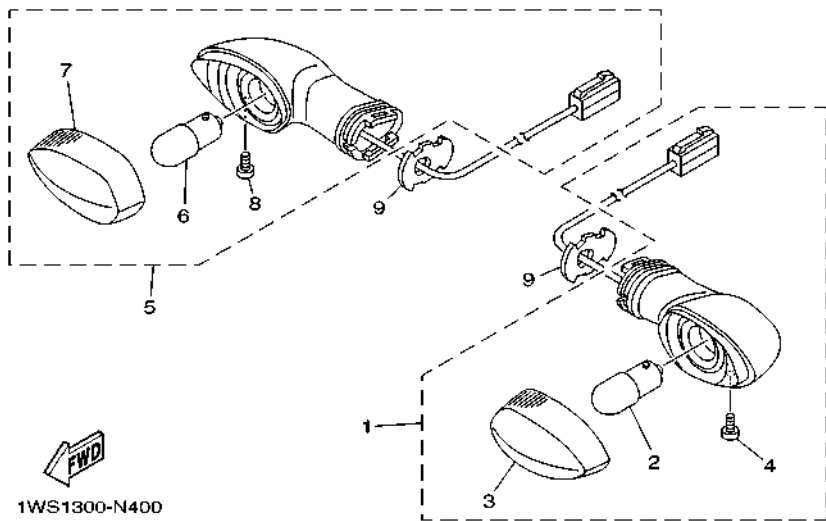
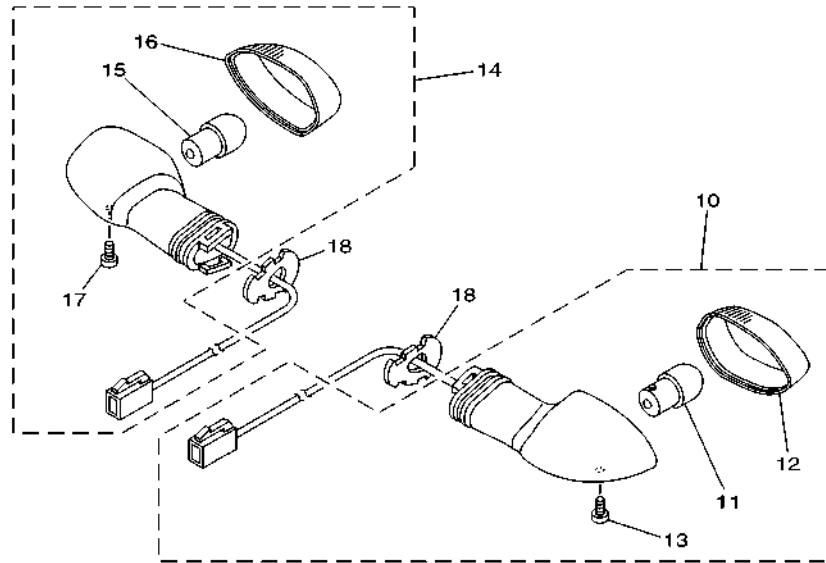

FIG. 39 STARTING MOTOR

REF. NO.	PART NO.	DESCRIPTION	B7S2	REMARKS
1	1WS-81890-00	MOTOR ASSY	1	
2	4B5-81844-00	.GASKET	2	
3	1FK-81847-00	.O-RING	1	
4	4XV-8182A-00	.NUT	1	
5	18P-81826-00	.BOLT	2	
6	18P-81801-00	.BRUSH SET	1	
7	1WS-81815-00	CORD, STARTER MOTOR	1	
8	4B5-81871-00	.CAP	1	
9	4XV-8182A-00	NUT	1	
10	91312-06025	BOLT, HEXAGON SOCKET HEAD	2	





 1WS1300-N400

FIG. 40 FLASHER LIGHT

REF. NO.	PART NO.	DESCRIPTION	B7S2				REMARKS
1	1WS-83310-00	FRONT FLASHER LIGHT ASSY 1	1				
2	1KB-83311-00	.BULB, FLASHER (12V-10W)	1				
3	1KB-8333A-00	.LENS COMP 1	1				
4	3D9-H3333-10	.SCREW, LENS FITTING	1				
5	1WS-83320-00	FRONT FLASHER LIGHT ASSY 2	1				
6	1KB-83311-00	.BULB, FLASHER (12V-10W)	1				
7	1KB-8334A-00	.LENS COMP 2	1				
8	3D9-H3333-10	.SCREW, LENS FITTING	1				
9	3D7-83318-10	STAY, FLASHER 1	2				
10	1WS-83330-00	REAR FLASHER LIGHT ASSY 1	1				
11	1KB-83311-00	.BULB, FLASHER (12V-10W)	1				
12	1KB-8334A-00	.LENS COMP 2	1				
13	3D9-H3333-10	.SCREW, LENS FITTING	1				
14	1WS-83340-00	REAR FLASHER LIGHT ASSY 2	1				
15	1KB-83311-00	.BULB, FLASHER (12V-10W)	1				
16	1KB-8333A-00	.LENS COMP 1	1				
17	3D9-H3333-10	.SCREW, LENS FITTING	1				
18	3D7-83318-10	STAY, FLASHER 1	2				

FIG. 41 METER

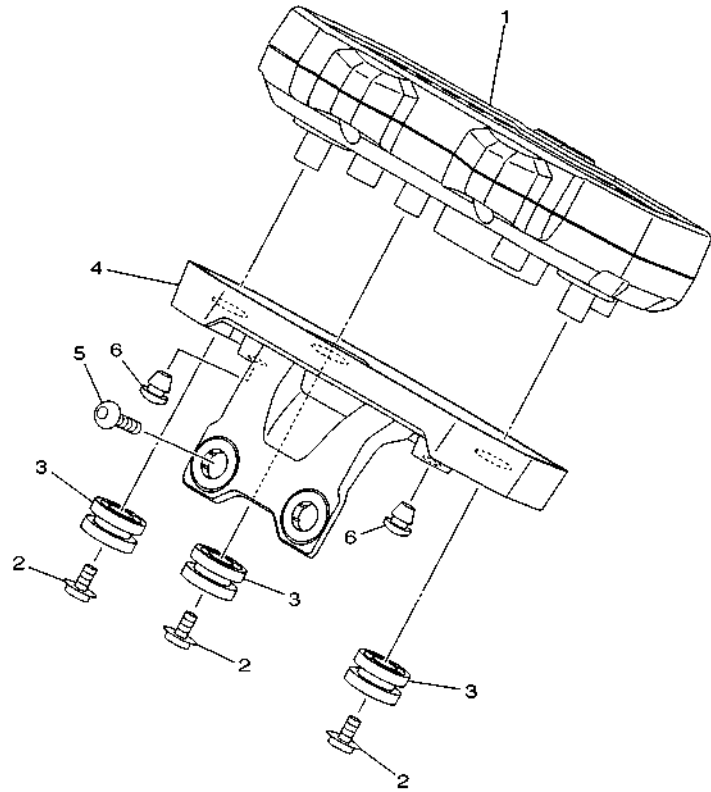
REF. NO.	PART NO.	DESCRIPTION	B7S2	REMARKS
1	BC6-83500-00	METER ASSY	1	KMH
2	90164-05001	SCREW, TAPPING	3	
3	5PS-83513-00	DAMPER	3	
4	1WS-83559-00	COVER, METER	1	
5	90111-06095	BOLT,HEX. SOCKET BUTTON	2	
6	90338-06018	PLUG	2	



1WS1300-N410

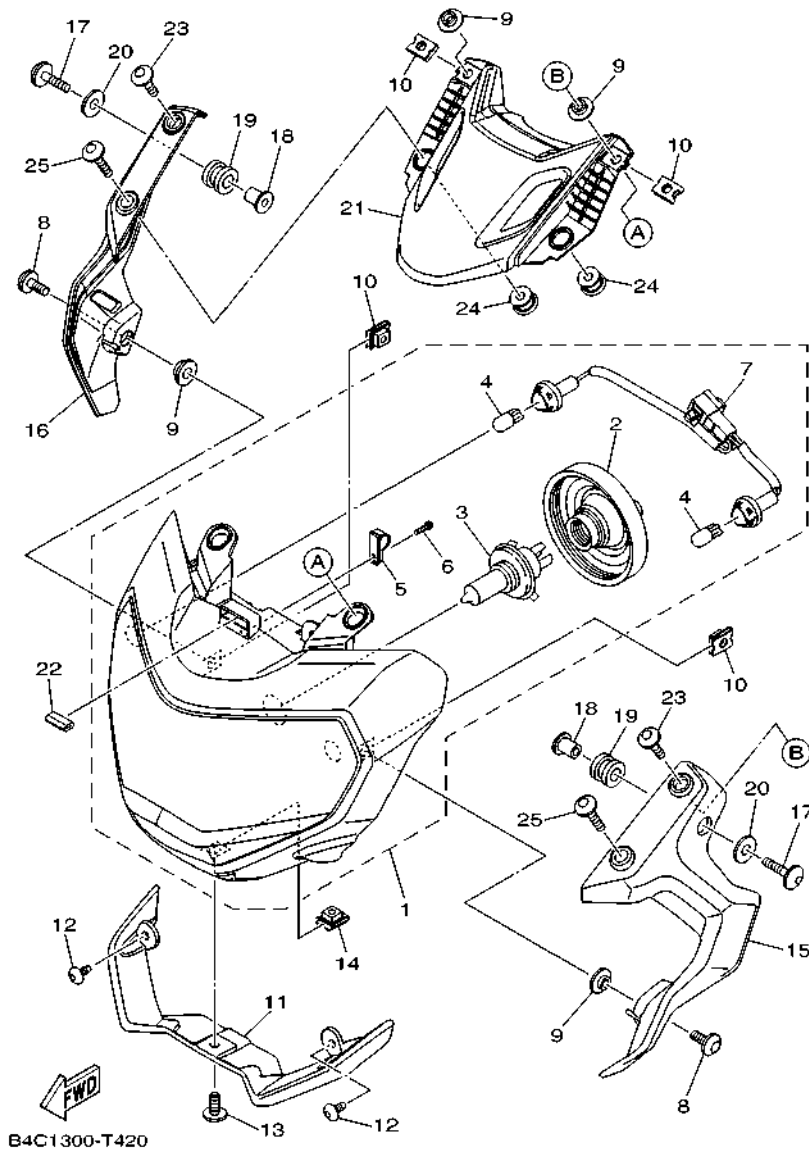
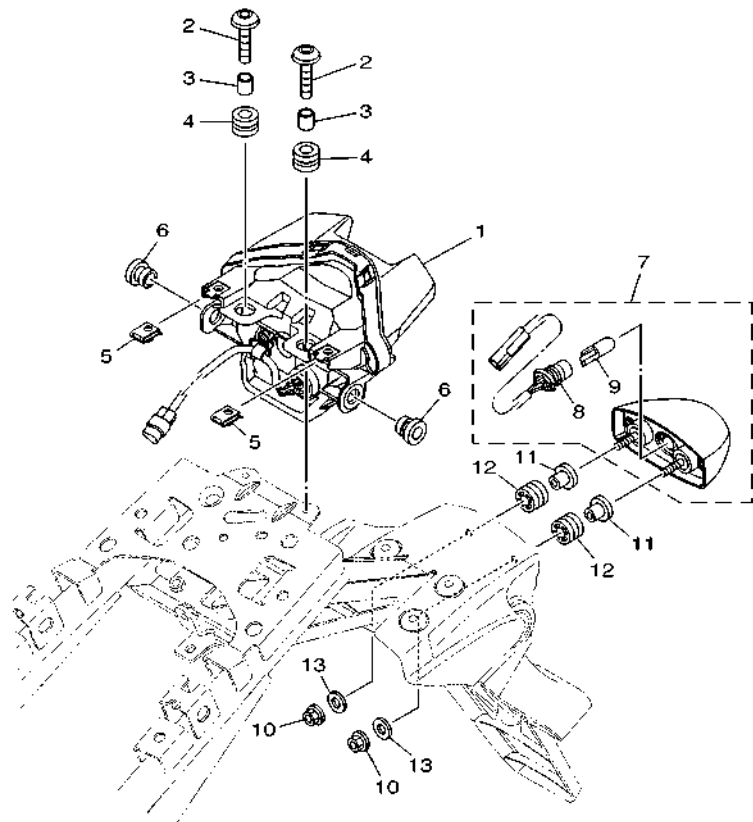

FIG. 42 HEADLIGHT

REF. NO.	PART NO.	DESCRIPTION	B7S2	REMARKS
1	B4C-84300-00	HEADLIGHT ASSY	1	
2	1RC-84397-00	.COVER, SOCKET	1	
3	1RC-84314-00	.BULB, HEADLIGHT (12V-60/55W)	1	
4	1RC-84347-00	.BULB (12V-5W)	2	
5	1RC-84746-00	.PLATE, SEAT BASE	1	
6	1RC-84724-00	.SCREW, LENS FITTING	1	
7	B4C-84359-00	.CORD, HEADLIGHT	1	
8	90111-06038	BOLT,HEX. SOCKET BUTTON	2	
9	90387-06170	COLLAR	4	
10	90183-061A7	NUT, SPRING	4	
11	B4C-28361-00-P0	PLATE, FRONT	1	UR FOR DPBMC
	B4C-28361-00-P4	PLATE, FRONT	1	UR FOR MLNM4
12	90167-05079	SCREW, TAPPING	2	
13	90111-06038	BOLT,HEX. SOCKET BUTTON	1	
14	90183-061A7	NUT, SPRING	1	
15	B4C-84118-00	STAY, HEADLIGHT 1	1	
16	B4C-84119-00	STAY, HEADLIGHT 2	1	
17	90111-06172	BOLT,HEX. SOCKET BUTTON	2	
18	90387-06301	COLLAR	2	
19	90480-12015	GROMMET	2	
20	90201-06029	WASHER, PLATE	2	
21	B4C-84396-00	COVER	1	
22	1WS-28376-00	TRIM	1	
23	90149-06302	SCREW	2	
24	90179-06072	NUT	2	
25	90149-06328	SCREW	2	

FIG. 43 TAILLIGHT



REF. NO.	PART NO.	DESCRIPTION	B7S2	REMARKS
1	B4C-84710-00	TAILLIGHT UNIT ASSY	1	
2	90111-06137	BOLT,HEX. SOCKET BUTTON	2	
3	90387-067V1	COLLAR	2	
4	90480-13001	GROMMET	2	
5	90183-05042	NUT, SPRING	2	
6	90480-10016	GROMMET	2	
7	1WS-84740-00	LICENCE LIGHT ASSY	1	
8	1WS-84547-00	.CORD, LICENCE LIGHT	1	
9	1TP-84347-00	.BULB (12V-5W)	1	
10	95602-05200	NUT, SELF-LOCKING	2	
11	90387-05042	COLLAR	2	
12	90480-12023	GROMMET	2	
13	90201-054K4	WASHER, PLATE	2	

B4C1300-T430

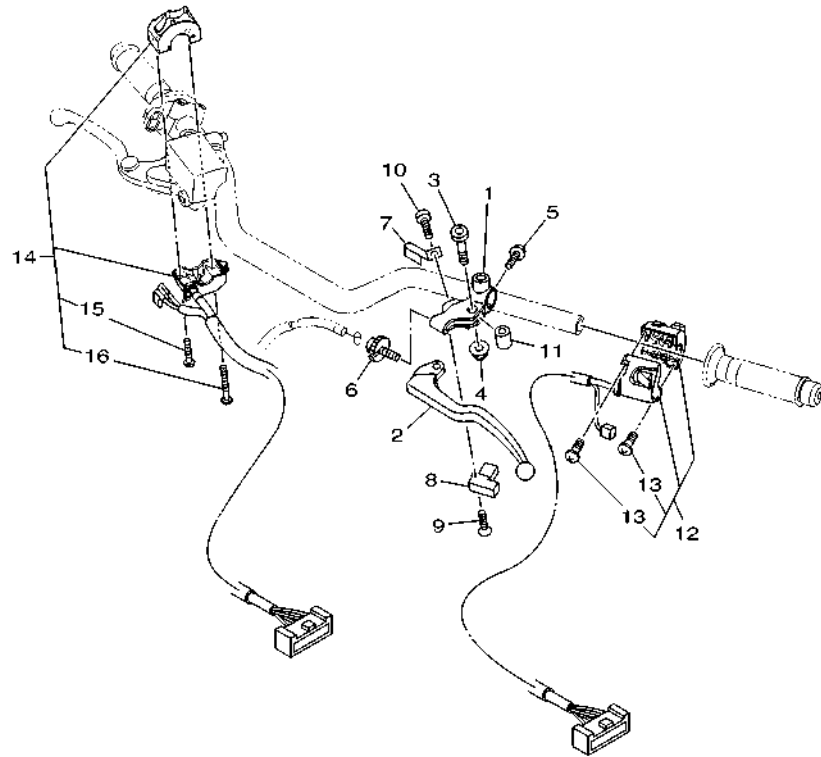



 B4C1300-T440

FIG. 44 HANDLE SWITCH & LEVER

REF. NO.	PART NO.	DESCRIPTION	B7S2				REMARKS
1	1B3-82911-00	HOLDER, LEVER 1	1				
2	5EB-83912-03	LEVER 1	1				
3	2C0-83945-00	BOLT, LEVER	1				
4	95607-06200	NUT, SELF U-FLANGE	1				
5	95027-06020	BOLT, FLANGE	1				
6	5LV-83951-00	BOLT, CABLE ADJUSTING	1				
7	4XV-83929-00	PLATE, SPRING	1				
8	3YX-82917-01	SWITCH	1				
9	98704-03020	SCREW, FLAT HEAD	1				
10	98507-04010	SCREW, PAN HEAD	1				
11	5JJ-83913-00	COLLAR, LEVER 1	1				
12	1WS-83972-01	SWITCH, HANDLE 4	1				
13	98507-04025	.SCREW, PAN HEAD	2				
14	1WS-83975-00	SWITCH, HANDLE 2	1				
15	98507-04020	.SCREW, PAN HEAD	1				
16	98507-04030	.SCREW, PAN HEAD	1				

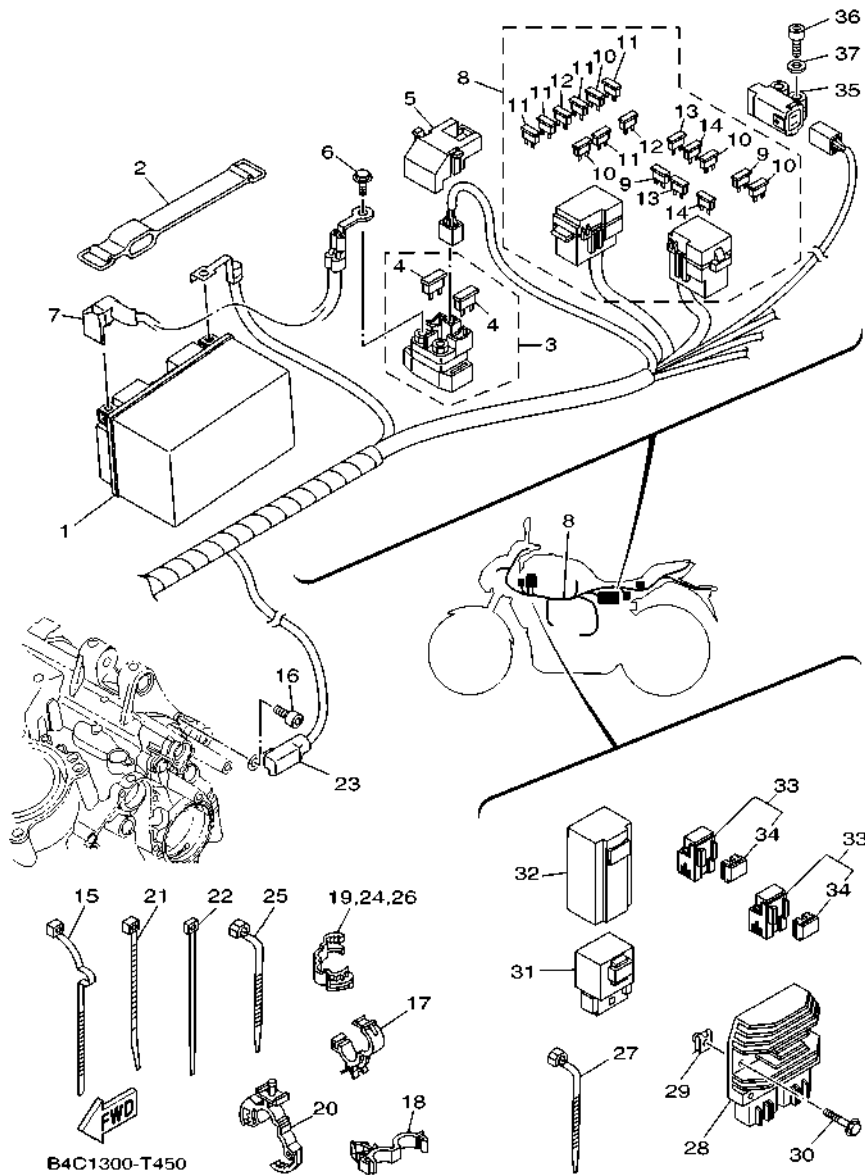
FIG. 45 ELECTRICAL 1



REF. NO.	PART NO.	DESCRIPTION	B7S2	REMARKS
1	5VY-82100-00	BATTERY ASSY (YUASA YTZ10S)	1	
2	1WS-82131-00	BAND, BATTERY	1	
3	1XC-81940-00	STARTER RELAY ASSY (RC19-089B)	1	
4	1AE-82151-00	.FUSE (30A-BL)	2	
5	5SL-82119-10	COVER, LEAD WIRE	1	
6	95022-06008	BOLT, FLANGE	2	
7	1XB-82115-01	WIRE, PLUS LEAD	1	
8	B4C-82590-00	WIRE HARNESS ASSY	1	
9	5JJ-82151-80	.FUSE (2A-BL)	2	
10	5JJ-82151-00	.FUSE (7.5A-BL)	4	
11	5JJ-82151-30	.FUSE (10A-BL)	5	
12	5JJ-82151-10	.FUSE (15A-BL)	2	
13	5JJ-82151-20	.FUSE (20A-BL)	2	
14	5JJ-82151-60	.FUSE (30A-BL)	2	
15	90464-07M40	CLAMP	1	
16	91380-06012	BOLT	1	
17	90464-20191	CLAMP	1	
18	90464-18007	CLAMP	1	
19	90464-14010	CLAMP	2	
20	90464-18011	CLAMP	1	
21	1UA-82591-00	BAND	2	
22	90464-65001	CLAMP	1	
23	1WS-81916-00	COVER, TERMINAL	1	
24	90464-14010	CLAMP	1	
25	90464-13073	CLAMP	1	(125.0x7.0)
26	90464-14010	CLAMP	1	
27	90464-25004	CLAMP	1	(101.0x7.0)

FIG. 45 ELECTRICAL 1

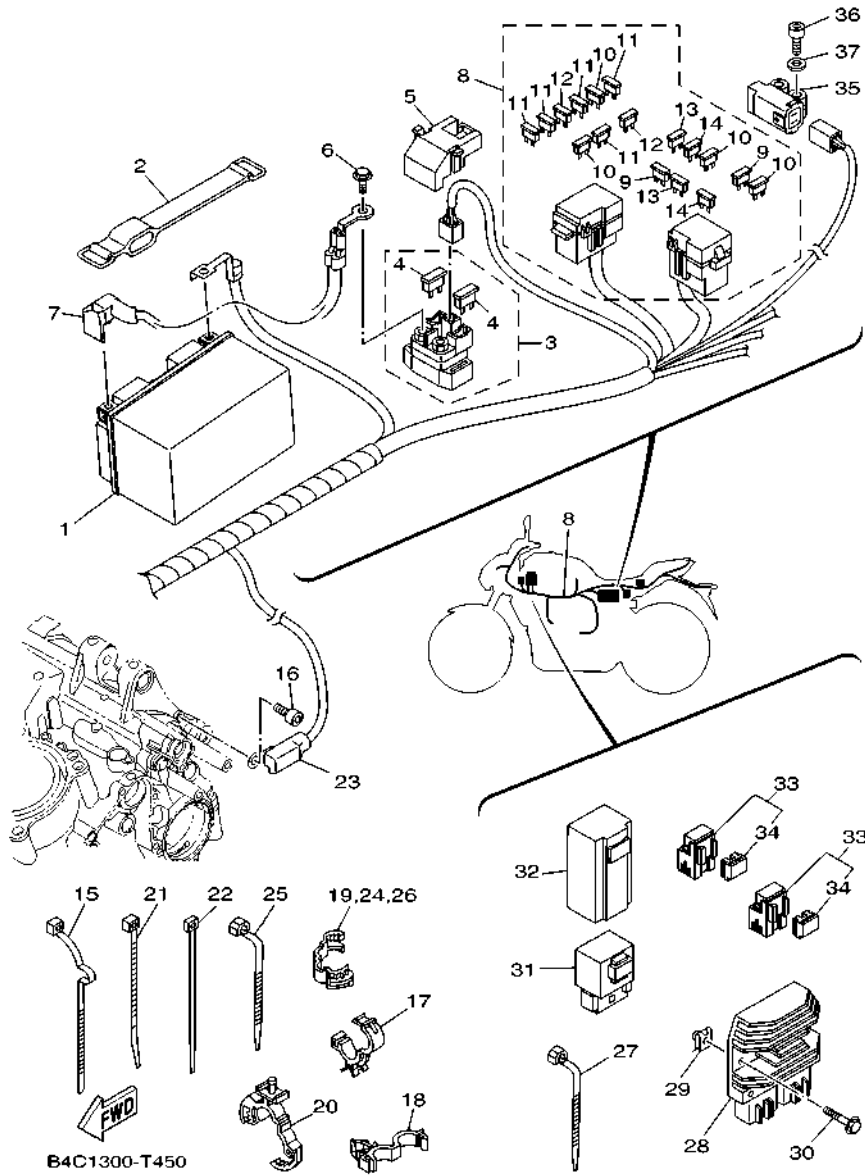

REF. NO.	PART NO.	DESCRIPTION	B7S2	REMARKS
28	1D7-81960-10	RECTIFIER & REGULATOR ASSY	1	
29	90183-060A6	NUT, SPRING	2	
30	95022-06025	BOLT, FLANGE	2	
31	5VK-81950-50	RELAY ASSY (G8R-30Y-V5)	1	
32	1WS-8246B-00	COVER 1	1	
33	1TP-81950-00	RELAY ASSY (1TP-00)	2	
34	5EA-81952-00	.HOLDER, RELAY	1	
35	5PS-82576-01	SENSOR, LEAN ANGLE	1	
36	91312-04025	BOLT, HEXAGON SOCKET HEAD	2	
37	90201-04030	WASHER, PLATE	2	

FIG. 46 ELECTRICAL 2

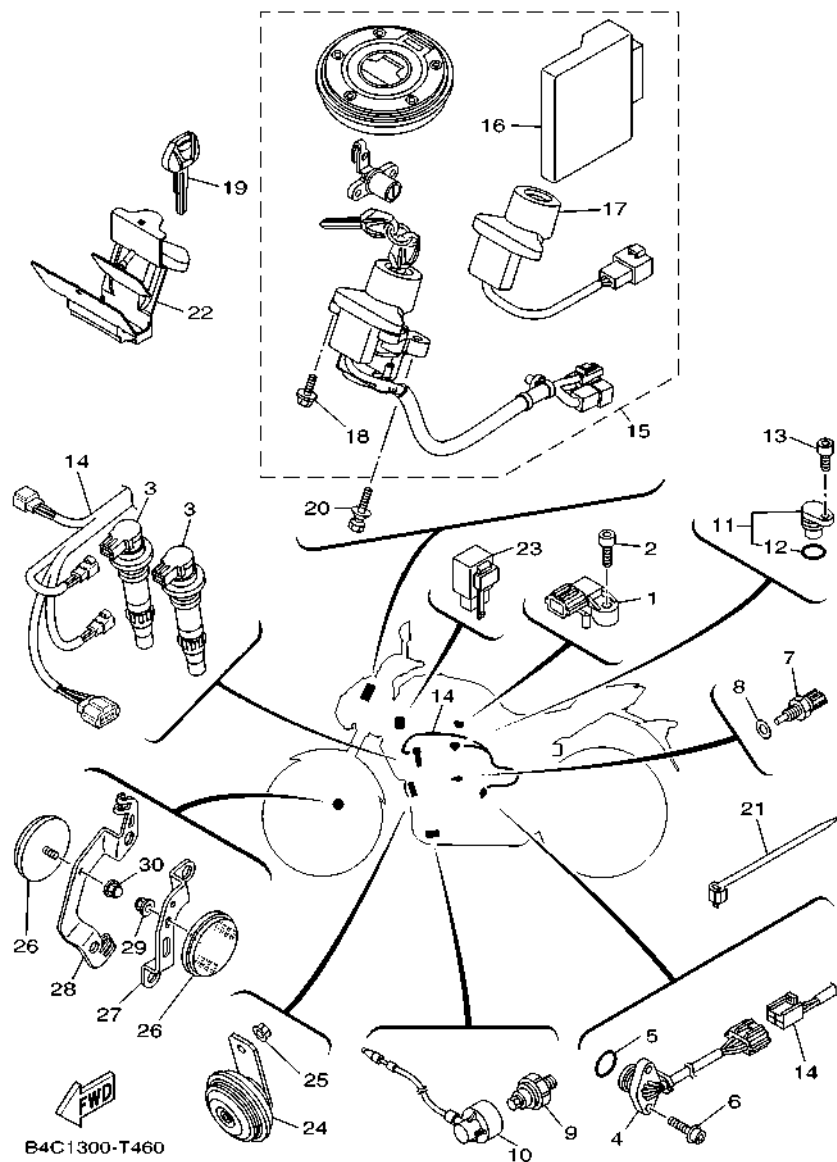

REF. NO.	PART NO.	DESCRIPTION	B7S2	REMARKS
1	1WS-82380-00	SENSOR, PRESSURE	1	
2	91312-05020	BOLT, HEXAGON SOCKET HEAD	1	
3	1WS-82310-00	IGNITION COIL ASSY	2	
4	1WS-82540-00	NEUTRAL SWITCH ASSY	1	
5	93210-21001	O-RING	1	
6	90110-05067	BOLT, HEXAGON SOCKET HEAD	2	
7	4P9-83591-00	THERMO UNIT	1	
8	90430-10004	GASKET	1	
9	1WS-82504-00	OIL PRESSURE SWITCH ASSY	1	
10	1WS-81315-00	LEAD WIRE ASSY	1	
11	3P6-15399-00	PLUG, BLIND	1	
12	93210-15566	.O-RING	1	
13	91312-06016	BOLT, HEXAGON SOCKET HEAD	1	
14	B2G-82309-00	WIRE, SUB LEAD	1	
15	BU2-W8250-20	MAIN SW. IMMOBILIZER KIT	1	
16	B34-8591A-00	.ENGINE CONTROL UNIT ASSY	1	
17	BU2-8255P-20	.IMMOBILIZER. UNIT COMP.	1	
18	5SL-82113-01	.SCREW	2	
19	5SL-82511-08	BLANK KEY	1	AP
20	90109-08196	BOLT	2	
21	90465-13M24	CLAMP	1	
22	1WS-81662-00	COVER, CONNECTER	1	
23	3XV-83350-21	FLASHER RELAY ASSY	1	
24	1WS-83371-00	HORN	1	
25	95707-06500	NUT, FLANGE	1	
26	4AG-85111-00	REFLECTOR, FRONT 1	2	
27	1WS-85112-00	BRACKET, REFLECTOR 1	1	

FIG. 47 ELECTRICAL 3

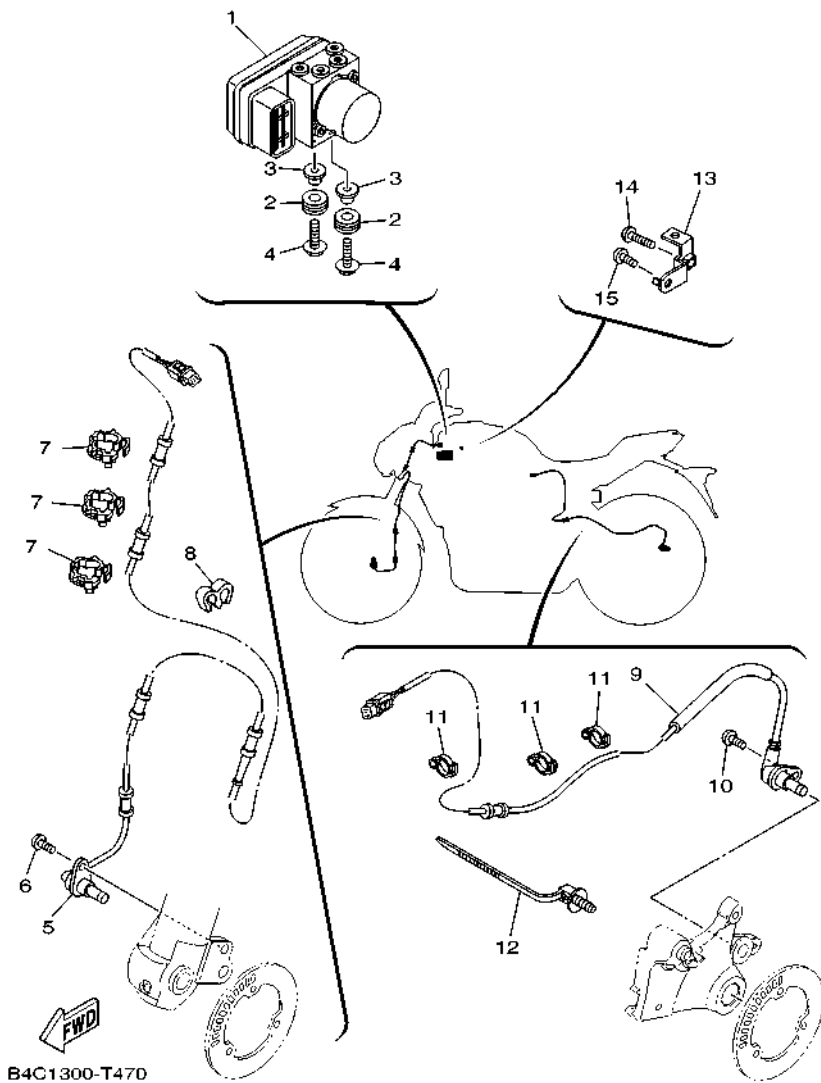

B4C1300-T470

REF. NO.	PART NO.	DESCRIPTION	B7S2				REMARKS
1	BC6-85930-09	HYDRAULIC UNIT ASSY	1				
2	90480-14229	GROMMET	3				
3	90387-06M60	COLLAR	3				
4	95817-06020	BOLT, FLANGE	3				
5	1XB-85970-00	WHEEL SENSOR ASSY, FRONT	1				
6	92014-06014	BOLT, BUTTON HEAD	1				
7	90464-12013	CLAMP	3				
8	90464-04001	CLAMP	2				
9	1XB-85980-00	WHEEL SENSOR ASSY, REAR	1				
10	92014-06014	BOLT, BUTTON HEAD	1				
11	90464-10233	CLAMP	3				
12	90464-30009	CLAMP	1				
13	1XB-2175T-00	BRACKET 1	1				
14	92012-06040	BOLT, BUTTON HEAD	1				
15	92012-06016	BOLT, BUTTON HEAD	1				

NUMERICAL INDEX

PART NO.	REF. NO.	PART NO.	REF. NO.	PART NO.	REF. NO.	PART NO.	REF. NO.	PART NO.	REF. NO.	PART NO.	REF. NO.
1WS-11101-09	1 - 1	1HX-12168-K1	3 - 10	1WS-12589-00	5 - 22	5EB-15155-00	12 - 2	1WS-17446-00	16 - 15	1WS-2164G-00	20 - 18
5VY-1111G-00	1 - 11	1HX-12168-M1	3 - 10	1WS-12671-00	6 - 3	1WS-15156-00	12 - 14	1WS-17460-00	16 - 40	B4C-21650-00	22 - 28
	1 - 22	1HX-12168-R1	3 - 10	5GJ-12675-00	6 - 4	1WS-15189-00	12 - 10	1WS-18101-00	18 - 4	1WS-21651-00	21 - 26
4D9-11133-01	1 - 2	1HX-12168-U1	3 - 10	5VY-13117-10	7 - 10	36Y-15189-00	12 - 8	B34-18110-00	35 - 32	BM5-21668-00	22 - 34
1WS-11165-01	1 - 17	1HX-12168-W1	3 - 10	1WS-13300-00	7 - 1	3KJ-15337-00	19 - 29	1WS-18112-00	18 - 14	1WS-21682-00	20 - 19
1WS-11166-00	9 - 21	1HX-12168-Y1	3 - 10	2CR-13338-00	5 - 35	2H7-15361-00	12 - 7	1WS-18113-00	35 - 33	B4C-21711-00-33	21 - 1
1WS-11169-00	1 - 18	1HX-12169-11	3 - 10	1WS-13400-00	8 - 5	3F9-15362-10	13 - 19		36 - 18	B4C-21711-00-P3	21 - 1
1WS-11181-00	1 - 14	1HX-12169-31	3 - 10	1WS-13410-00	7 - 7	1WS-15377-00	13 - 11	B4C-18115-00	35 - 38	B4C-2171E-00	21 - 8
1WS-11190-01	1 - 16	1HX-12169-50	3 - 10	1WS-13414-00	8 - 8	3P6-15399-00	46 - 11	5VX-18116-00	35 - 28	B4C-2171L-00	21 - 12
1WS-11193-01	1 - 20	1HX-12169-70	3 - 10	5GH-13440-60	8 - 4	1WS-15411-00	13 - 1	1D7-18127-00	18 - 3	B4C-2171M-00	21 - 24
214-11198-01	8 - 7	1HX-12169-90	3 - 10	1WS-13470-00	8 - 1	1WS-15416-00	12 - 21	1WS-18140-00	18 - 7	B4C-2171X-00	21 - 20
1WS-11400-00	2 - 1	1HX-12169-E0	3 - 10	1XD-13475-00	8 - 2	1WS-15418-00	13 - 10	5VX-18154-00	35 - 29	B4C-21721-00-33	21 - 13
2S3-11413-00	2 - 22	1HX-12169-G0	3 - 10	1WS-13542-00	9 - 4	1WS-15421-00	5 - 25	2C0-18175-00	18 - 6	B4C-21721-00-P3	21 - 13
2S3-11413-10	2 - 22	1HX-12169-J0	3 - 10	8FP-13556-00	10 - 2	1WS-15441-00	13 - 17	1WS-18511-00	17 - 4	1WS-2172W-00	6 - 20
2S3-11413-20	2 - 22	1HX-12169-L0	3 - 10	8GL-13571-00	10 - 12	1WS-15451-00	13 - 6	1WS-18512-00	17 - 5	B4C-2172X-00	21 - 25
2S3-11413-30	2 - 22	1HX-12169-N0	3 - 10	8HG-13573-00	10 - 11	1WS-15456-00	12 - 22	1WS-18513-00	17 - 6	B4C-21731-00	6 - 28
2S3-11413-40	2 - 22	1HX-12169-T0	3 - 10	1WS-13635-00	9 - 1	1WS-15461-00	13 - 13	20S-18535-00	17 - 7	B4C-21741-00	6 - 29
3GM-11416-00	2 - 5	1WS-12170-00	4 - 1	1WS-13750-10	10 - 1	1WS-15484-00	38 - 5	1WS-18536-00	17 - 8	1WS-21746-00	20 - 20
3GM-11416-10	2 - 5	2C0-12176-00	4 - 2	1WS-13761-00	10 - 3	1WS-15512-00	14 - 5	1WS-18540-00	17 - 1	1XB-2175T-00	47 - 13
3GM-11416-20	2 - 5	1WS-12180-00	4 - 4	1WS-13898-00	7 - 5	1WS-15515-00	14 - 1	3D7-18542-00	17 - 2	1WS-2175U-00	19 - 38
3GM-11416-A0	2 - 5	1WS-12181-00	4 - 5	1WS-13907-00	26 - 16	23P-15521-00	14 - 4	BU2-21110-10	19 - 1	B4C-217F1-00	27 - 47
3GM-11416-B0	2 - 5	1WS-12210-02	4 - 13	1WS-13938-00	10 - 10	1WS-15560-00	14 - 6	B4C-2112B-00	19 - 16	B4C-217F1-40	27 - 47
1WS-11454-00	2 - 14	1WS-12213-00	4 - 16	1WS-13971-00	26 - 23	1WS-15590-00	14 - 2	B4C-21131-00	28 - 8	B4C-217F2-00	27 - 48
1WS-11496-00	2 - 15	5SL-12214-00	4 - 15	2C0-14105-00	10 - 20	1WS-16150-00	15 - 1	B4C-2113C-00	19 - 17	B4C-217F2-40	27 - 48
1WS-11500-00	2 - 13	5EL-12228-00	4 - 14	8A7-14139-00	10 - 22	363-16154-00	15 - 2	1WS-21158-00	19 - 25	1WS-21816-00	6 - 18
1WS-11531-00	2 - 16	1WS-12247-00	4 - 9	5PS-14147-00	10 - 4		15 - 13	23P-2117K-00	28 - 18	26H-21828-00	6 - 14
1WS-11533-00	2 - 19	1WS-12251-00	4 - 18	895-14169-00	10 - 21	1WS-16181-00	15 - 11	1WS-2117N-00	19 - 19	1WS-21871-00	6 - 13
1WS-11603-00	2 - 7	1WS-12252-00	4 - 19	8CC-14216-10	10 - 14	5TG-16321-00	15 - 6	1WS-2117R-00	19 - 40	3P6-21875-00	6 - 16
1WS-11631-00	2 - 6	1WS-12257-00	4 - 10	54P-14243-00	10 - 9	5VY-16321-00	15 - 4	1WS-2117T-00	19 - 42	1WS-2191B-00	19 - 2
1WS-11633-00	2 - 8	1WS-12280-00	4 - 7	1WS-14335-00	10 - 7	5VY-16325-00	15 - 5	5VN-21268-00	19 - 48	B4C-21946-00	19 - 15
1WS-11650-00	2 - 2	1PD-12288-00	4 - 11	B4C-14401-00	9 - 5	1WS-16340-00	15 - 18	BU2-21288-00	19 - 46	1WS-22110-10	22 - 1
1RC-11654-00	2 - 3	1WS-12405-00	6 - 2	1WS-14430-10	9 - 11	132-16346-00	18 - 2	1WS-21315-00	19 - 9	4FN-22141-00	31 - 27
1RC-11656-00	2 - 4	1WS-12410-00	5 - 17	1WS-14437-10	9 - 12	1WS-16350-00	15 - 7	1WS-21316-00	19 - 10	1UY-22141-10	22 - 8
1RC-11656-10	2 - 4	1WS-12413-00	5 - 18	1WS-1443E-00	9 - 14	1WS-16356-00	15 - 17	4XV-21376-00	19 - 33	1WS-22151-00	22 - 25
1RC-11656-20	2 - 4	1WS-12420-01	5 - 24	1WS-14450-00	9 - 6	1WS-16371-01	15 - 3	B4C-2137W-01	27 - 7	1WS-22174-00	31 - 23
1RC-11656-30	2 - 4	1WS-12422-00	5 - 37	1WS-14452-00	9 - 7	2D1-16382-00	5 - 26	B4C-2137X-01	27 - 24	1WS-22175-00	31 - 24
1WS-12111-01	3 - 1	5VK-12438-00	5 - 34	1WS-14465-00	10 - 18	1WS-17121-00	16 - 13	2S3-21398-00	28 - 27	1WS-2217A-00	22 - 11
1WS-12113-01	3 - 3	1WS-12439-00	5 - 38	14B-14466-00	10 - 19	1WS-17131-00	16 - 6	20S-21445-01	11 - 7	1WS-2217F-00	22 - 19
1WS-12114-00	3 - 4	1WS-12450-00	5 - 32	1WS-14469-00	9 - 8	1WS-17151-00	16 - 2	B4C-2144G-00	37 - 19	1WS-22184-00	22 - 24
1WS-12116-00	3 - 8	B34-12461-00	6 - 1	1WS-1446C-00	9 - 9	1WS-17161-00	16 - 9	B4C-21511-00	20 - 1	1WS-22189-00	22 - 18
1WS-12117-00	3 - 5	3D7-12462-00	6 - 8	8HG-14534-00	10 - 13	1WS-17211-00	16 - 38	1XC-21568-00	27 - 46	30X-2219X-00	22 - 5
1WG-12118-00	3 - 6	1WS-12469-00	5 - 14	4XY-14568-00	6 - 19	1WS-17221-00	16 - 22	1WS-2161G-00	20 - 21	B4C-22210-00	23 - 1
4TE-12119-00	3 - 7	1WS-12481-00	5 - 1		26 - 29	1WS-17231-00	16 - 33	1WS-2161J-00	19 - 36	B4C-22210-40	23 - 1
1WS-12121-00	3 - 2	1WS-12482-00	5 - 3	3YF-14613-01	11 - 5	1WS-17241-00	16 - 29	1WS-21629-00	20 - 14	BU2-22358-00	22 - 2
4C8-12153-09	3 - 9	1WS-12576-00	5 - 9	1WS-14708-00	11 - 2	1WS-17251-00	16 - 37	1WS-21639-00	20 - 5	B4C-23102-00	25 - 20
4C8-12153-10	3 - 9		5 - 10	BU2-14710-00	11 - 1	1WS-17261-00	16 - 26	1WS-2163A-00	20 - 23	B4C-23103-00	25 - 1
1HX-12168-F0	3 - 10	1WS-12578-00	6 - 10	1WS-15100-08	12 - 1	1WS-17401-00	16 - 1	1WS-21642-00	20 - 12	1WS-23110-00	25 - 3
1HX-12168-H1	3 - 10	1WS-12588-00	5 - 20	1WS-15128-00	12 - 24	1WS-17421-00	16 - 17	1WS-2164F-00	20 - 17		25 - 22

NUMERICAL INDEX

PART NO.	REF. NO.	PART NO.	REF. NO.	PART NO.	REF. NO.	PART NO.	REF. NO.	PART NO.	REF. NO.	PART NO.	REF. NO.
1D0-23111-00	25 - 17	1WS-24135-00	26 - 38	1WS-2537W-00	31 - 17	B4C-2584E-00	37 - 24	1WS-26301-00	33 - 5	137-28152-00	28 - 24
	25 - 36	B4C-24139-00-P0	27 - 18	1RC-25383-00	31 - 12	2C0-25852-00	37 - 11	2C0-26326-00	37 - 15	14B-28164-00	28 - 22
3FW-23118-00	25 - 16	B4C-24139-00-P4	27 - 18	1WS-25388-00	31 - 22	5VS-25852-00	34 - 3	5VS-26332-00	34 - 10	23P-28164-00	28 - 25
	25 - 35	1RC-2413B-01	27 - 44	1WS-2538D-00	31 - 30	20S-25854-00	34 - 5	1WS-26335-00	33 - 11	4KG-28186-10	28 - 28
4KM-23123-01	25 - 43		27 - 45	1WS-2538N-00	31 - 31	2VN-25854-00	37 - 12	157-27114-00	28 - 9	B4C-28361-00-P0	42 - 11
4FM-23125-40	25 - 9	B4C-2413Y-00	26 - 9	5MT-25398-00	29 - 7	2VN-25855-00	37 - 13	278-27114-00	26 - 13	B4C-28361-00-P4	42 - 11
	25 - 28	3HA-24141-00	19 - 50		31 - 9	5VS-25855-00	34 - 4		28 - 13	B4C-2836K-00	27 - 11
1WS-23126-01	25 - 21	1WS-2414H-00	26 - 42	5MT-25398-10	29 - 7	4BP-2585F-01	37 - 4	371-27114-00	28 - 3	B4C-2836L-00	27 - 28
1XB-23136-01	25 - 2	1WS-2414J-00	26 - 43		31 - 9	5VS-25867-00	34 - 11	5UY-27114-00	26 - 12	5DM-28371-00	19 - 31
BC6-23141-00	25 - 14	2C0-2414R-00	27 - 6	5MT-25398-20	29 - 7	1XB-25872-00	34 - 16	5VX-27114-00	35 - 27	1WS-28376-00	42 - 22
	25 - 33		27 - 23		31 - 9	1XB-25875-00	34 - 22		36 - 14	B4C-2837N-00	27 - 12
4EB-23144-00	25 - 5	2RC-24170-00	26 - 35	1WS-25443-00	31 - 14	1XB-25876-00	34 - 24	B4C-27211-00	36 - 17	B4C-2837R-00	27 - 29
	25 - 24	B4C-24181-00	27 - 8	4SV-25802-00	30 - 8	1WS-2587A-00	34 - 23	4BP-27222-02	37 - 5	1WS-81315-00	46 - 10
4EB-23145-01	25 - 7	2RC-24182-00	26 - 34		30 - 20	1XB-25886-00	34 - 25	1WS-27311-00	35 - 3	1WS-81410-00	38 - 1
	25 - 26	B4C-24182-00	27 - 25	5SL-25802-00	32 - 6	BU2-25887-00	22 - 30	5VX-27315-00	35 - 11	1WS-81450-01	38 - 2
36Y-23146-10	25 - 8	3D7-24188-00	26 - 44	4SV-25802-10	30 - 6	1WS-2588F-00	22 - 31	1WS-27321-00	35 - 16	1WS-81662-00	46 - 22
	25 - 27	1WS-2419A-00	35 - 13		30 - 18	14B-25894-00	37 - 10	5VX-27351-00	35 - 10	18P-81801-00	39 - 6
3EN-23149-50	25 - 15	2RC-2419F-00	26 - 40	5SL-25803-00	32 - 7	1WS-25895-00	37 - 17	3YX-27413-00	35 - 22	1WS-81815-00	39 - 7
	25 - 34	2RC-24318-00	26 - 25	3GM-25803-10	30 - 7	5VS-2589F-00	34 - 7		36 - 9	18P-81826-00	39 - 5
26H-23156-00	25 - 6	B2G-24321-00	26 - 27		30 - 19	5VS-2589H-00	34 - 6	36Y-27414-00	35 - 26	4XV-8182A-00	39 - 4
	25 - 25	B2G-24322-00	26 - 30	3MA-25803-10	30 - 9	5SL-25914-00	32 - 11		36 - 13		39 - 9
509-23158-L0	25 - 12	2RC-24323-00	26 - 32		30 - 21	5DH-25916-00	32 - 16	1HX-27415-00	19 - 30	4B5-81844-00	39 - 2
	25 - 31	2RC-24324-00	26 - 36	1WS-25805-00	30 - 10	3JD-25917-00	32 - 13		19 - 41	1FK-81847-00	39 - 3
B4C-23170-00	25 - 10	3D7-24339-00	26 - 3		30 - 22	5SL-25917-00	32 - 8		19 - 43	4B5-81871-00	39 - 8
	25 - 29	1RC-24486-00	26 - 18	5VX-25806-00	32 - 14	13S-25919-00	30 - 11	1WS-2741L-01	35 - 54	1WS-81890-00	39 - 1
5BN-23171-00	25 - 4	1WS-24491-00	26 - 17	1WS-25807-00	34 - 2		30 - 23	1WS-27425-00	35 - 49	1WS-81916-00	45 - 23
	25 - 23	1WS-24602-00	26 - 20	1XB-2580A-00	34 - 1	5SL-25919-00	32 - 10		36 - 30	1XC-81940-00	45 - 3
4YR-23173-00	25 - 11	1WS-2463E-00	27 - 43	1WS-2580T-00	30 - 5	2DR-25921-50	32 - 12	1WS-2742L-01	36 - 35	1TP-81950-00	45 - 33
	25 - 30	B4C-2464E-00	27 - 35	1XB-2580U-00	30 - 17	4SV-25924-00	30 - 12	3VR-27431-02	35 - 53	5VK-81950-50	45 - 31
278-23181-50	25 - 13	B4C-2470F-00	28 - 2	2DR-2580W-00	32 - 5		30 - 24	4BP-27434-01	35 - 36	5EA-81952-00	45 - 34
	25 - 32	B4C-24710-00	28 - 1	1WS-2581T-00	30 - 1	8CR-25924-00	32 - 15		36 - 20	1D7-81960-10	45 - 28
43F-23188-10	25 - 18	3UF-24737-00	19 - 28	1J3-25824-00	30 - 14	3GM-25925-00	30 - 13	5VX-27437-00	35 - 57	5VY-82100-00	45 - 1
	25 - 37	22W-24741-00	28 - 4	5VS-25824-00	30 - 26		30 - 25		36 - 38	5SL-82113-01	46 - 18
1WS-2331G-00	25 - 38	B4C-24750-00	28 - 12	8CR-25824-00	32 - 18	1RC-25926-00	32 - 17	3VR-27441-02	36 - 34	1XB-82115-01	45 - 7
B34-23340-00	25 - 39	B4C-2477A-00	28 - 20	306-25825-01	30 - 15	5VS-25975-00	30 - 28	1WS-27442-10	35 - 25	5SL-82119-10	45 - 5
B4C-2334G-00	24 - 13	1WS-24780-00	28 - 14		30 - 27	B4C-26111-00	33 - 1	1WS-27443-10	36 - 12	1WS-8212B-00	20 - 4
B4C-2334H-00	24 - 18	1WS-2478E-00	28 - 16	1UY-25825-51	32 - 19	1WS-2612E-00	33 - 12	1WS-27445-10	35 - 30	1WS-82131-00	45 - 2
1WS-23357-00	24 - 3	2PP-25117-00	29 - 2	5SL-25827-00	32 - 20	23P-26133-00	33 - 17	1WS-27446-10	36 - 15	1AE-82151-00	45 - 4
1W1-23416-00	24 - 2	1XB-25168-00-P0	29 - 1	5SL-25827-10	32 - 21		33 - 19	1WS-27451-00	35 - 18	5JJ-82151-00	45 - 10
BC6-23430-00	24 - 4	1XB-25168-00-P5	29 - 1	5SL-25828-01	32 - 22	1WS-26240-00	33 - 3	1WS-27453-10	35 - 45	5JJ-82151-10	45 - 12
1E6-23441-10-P0	24 - 11	2DR-2517G-00	30 - 3	2D1-2582A-00	37 - 3	4YR-26241-02	33 - 2	1WS-27461-00	36 - 5	5JJ-82151-20	45 - 13
1WS-23442-00-P0	24 - 7		32 - 3	5RU-26246-00	37 - 20	1WS-26246-00	33 - 4	1WS-27463-10	36 - 26	5JJ-82151-30	45 - 11
3FV-23462-00	25 - 40	3MA-25181-10	29 - 9	1WS-2582W-00	32 - 1	39P-2627E-00	33 - 7	1WS-27475-00-P0	35 - 52	5JJ-82151-60	45 - 14
B4C-24110-00	26 - 1	2PP-25317-00	31 - 5	5SL-25838-00	32 - 9	B5C-26280-00	33 - 16		36 - 33	5JJ-82151-80	45 - 9
B4C-2411J-00	26 - 24	2DR-25338-00-P0	31 - 1	4P5-2583V-00	37 - 1	1WS-26281-00	33 - 8	B34-274A3-00	35 - 1	B2G-82309-00	46 - 14
B4C-24129-00-P0	27 - 1	2DR-25338-00-P6	31 - 1	BU2-2584A-00	34 - 17	1WS-26282-00	33 - 9	B34-274A4-00	36 - 1	1WS-82310-00	46 - 3
B4C-24129-00-P4	27 - 1	5SL-25364-00	31 - 6	BU2-2584B-00	34 - 18	B5C-26290-00	33 - 18	B4C-28100-00	28 - 26	1WS-82380-00	46 - 1
1WS-2412Y-00	26 - 2	5JJ-25366-00	31 - 10	B4C-2584D-00	37 - 23	1WS-26296-00	34 - 27	2H7-28151-00	28 - 23	1WS-8246B-00	45 - 32

NUMERICAL INDEX

PART NO.	REF. NO.	PART NO.	REF. NO.	PART NO.	REF. NO.	PART NO.	REF. NO.	PART NO.	REF. NO.	PART NO.	REF. NO.
1WS-82504-00	46 - 9	B4C-84396-00	42 - 21	90105-12092	19 - 7	90111-05011	21 - 21	90170-08010	37 - 6	90201-20030	15 - 14
5SL-82511-08	46 - 19	1RC-84397-00	42 - 2	90105-126A8	2 - 11		27 - 36	90176-06014	46 - 30	90206-12074	35 - 35
B2G-82530-00	37 - 18	1WS-84527-00	24 - 14	90109-06100	12 - 19	90111-06038	42 - 8	90176-10003	24 - 10		36 - 19
1WS-82540-00	46 - 4	1WS-84547-00	43 - 8	90109-06202	20 - 6		42 - 13	90179-06072	42 - 24	90208-20001	15 - 15
BU2-8255P-20	46 - 17	B4C-84710-00	43 - 1	90109-06259	21 - 2	90111-06060	11 - 3	90179-08410	11 - 6	90208-22002	16 - 41
1WS-82566-00	35 - 12	1RC-84724-00	42 - 6		21 - 14	90111-06084	26 - 14	90179-10024	19 - 5	90209-08295	35 - 42
5PS-82576-01	45 - 35	1WS-84740-00	43 - 7	90109-06293	1 - 10		27 - 39	90179-20007	15 - 16		36 - 25
B4C-82590-00	45 - 8	1RC-84746-00	42 - 5	90109-06295	4 - 20	90111-06089	20 - 16	90179-22018	16 - 42	90209-21332	16 - 4
1UA-82591-00	45 - 21	4AG-85111-00	46 - 26	90109-06317	27 - 14	90111-06095	41 - 5	90183-04039	20 - 9		16 - 8
1B3-82911-00	44 - 1	1WS-85112-00	46 - 27		27 - 31	90111-06101	33 - 13	90183-05042	43 - 5	90209-21351	16 - 12
3YX-82917-01	44 - 8	1XB-85122-00	46 - 28	90109-064G6	30 - 2	90111-06119	22 - 28	90183-05076	21 - 6	90209-22352	16 - 11
1WS-83310-00	40 - 1	3Y6-85130-02	20 - 25	90109-066F0	1 - 21		26 - 41		21 - 18	90209-28008	16 - 24
1KB-83311-00	40 - 2	1WS-85801-00	10 - 5	90109-08045	32 - 2	90111-06122	19 - 35		27 - 2		16 - 28
	40 - 6	3B4-85885-00	10 - 15	90109-08196	46 - 20	90111-06137	43 - 2		27 - 9		16 - 35
	40 - 11	5YU-85886-00	26 - 5	90109-086F8	35 - 24	90111-06139	28 - 7		27 - 19	90214-28002	16 - 32
	40 - 15	B34-8591A-00	46 - 16		36 - 11	90111-06151	6 - 31		27 - 26	90214-29002	16 - 31
3D7-83318-10	40 - 9	1WS-8592A-00	11 - 4	90110-05067	46 - 6		20 - 2		27 - 38	90240-08005	37 - 7
	40 - 18	BC6-85930-09	47 - 1	90110-05071	35 - 14	90111-06156	6 - 7	90183-05M02	27 - 13	90269-06002	19 - 24
1WS-83320-00	40 - 5	1XB-85970-00	47 - 5	90110-05112	26 - 21	90111-06172	42 - 17		27 - 30		20 - 13
1WS-83330-00	40 - 10	1XB-85980-00	47 - 9	90110-06081	1 - 13	90111-08022	36 - 16	90183-060A6	45 - 29	90269-06008	6 - 21
1KB-8333A-00	40 - 3	54P-E416A-00	10 - 6	90110-06152	5 - 8	90111-10006	35 - 2	90183-061A7	42 - 10		21 - 5
	40 - 16	3D9-H3333-10	40 - 4	90110-06163	6 - 23		36 - 2		42 - 14		21 - 17
1WS-83340-00	40 - 14		40 - 8	90110-06168	7 - 6	90111-10059	35 - 17	90185-10023	35 - 8		21 - 29
1KB-8334A-00	40 - 7		40 - 13	90110-06172	26 - 7	90116-08087	1 - 8	90185-16002	22 - 10		27 - 4
	40 - 12		40 - 17	90110-06173	7 - 11	90116-10048	31 - 15	90185-18009	31 - 28		27 - 21
3XV-83350-21	46 - 23	5VX-W0042-51	37 - 2	90110-06177	38 - 3	90119-06209	19 - 21	90201-04030	45 - 37	90269-07007	22 - 29
1WS-83371-00	46 - 24	2TV-W2470-00	28 - 17	90110-06274	5 - 40	90119-06263	15 - 10	90201-054K4	43 - 13	90269-07008	20 - 24
BC6-83500-00	41 - 1	BU2-W8250-20	46 - 15	90110-06388	13 - 8	90119-09014	12 - 12	90201-06029	42 - 20	90269-07077	19 - 39
3C3-83513-00	24 - 15	90101-06043	12 - 11		13 - 15	90119-09018	12 - 13	90201-064K6	9 - 20	90269-08008	35 - 51
5PS-83513-00	41 - 3	90101-10025	35 - 4	90110-06389	13 - 9	90119-10056	1 - 12	90201-08053	35 - 37		36 - 32
1WS-83559-00	41 - 4	90101-12049	22 - 20		13 - 18	90149-05029	30 - 4		36 - 22	90280-05029	2 - 10
4P9-83591-00	46 - 7	90105-05024	1 - 19	90110-06395	12 - 23		32 - 4	90201-08070	37 - 8	90282-04001	2 - 20
5EB-83912-03	44 - 2	90105-06027	1 - 5	90110-06396	4 - 17	90149-06030	28 - 19	90201-10029	15 - 20	90331-16001	4 - 6
5JJ-83913-00	44 - 11	90105-06148	37 - 26		13 - 12	90149-06105	35 - 48	90201-10035	19 - 6	90338-06018	20 - 7
5VS-83922-00	34 - 9	90105-06206	20 - 22	90110-08071	35 - 41		36 - 29		35 - 7		41 - 6
4XV-83929-00	44 - 7	90105-07006	4 - 3		36 - 24	90149-06109	38 - 4	90201-10043	24 - 9	90338-16262	12 - 5
2C0-83945-00	44 - 3		4 - 8	90110-08111	19 - 12	90149-06158	17 - 9	90201-10045	22 - 13	90340-14132	8 - 6
5LV-83951-00	44 - 6	90105-08021	21 - 3	90110-08231	35 - 60	90149-06189	16 - 16		31 - 18	90340-18002	1 - 6
1WS-83972-01	44 - 12		21 - 15		36 - 41	90149-06302	42 - 23	90201-12008	2 - 12	90340-36005	13 - 2
1WS-83975-00	44 - 14	90105-08164	11 - 8	90110-10044	19 - 11	90149-06328	42 - 25	90201-12051	35 - 34	90380-16158	22 - 7
1HP-83980-01	34 - 12	90105-10212	23 - 5	90111-05002	27 - 37	90149-08030	14 - 3		36 - 21	90387-05021	21 - 27
B4C-84118-00	42 - 15	90105-10219	19 - 3	90111-05003	21 - 7	90157-05025	35 - 23	90201-12575	18 - 12	90387-05028	37 - 14
B4C-84119-00	42 - 16	90105-10283	23 - 2		21 - 19		36 - 10	90201-13020	19 - 8	90387-05042	43 - 11
B4C-84300-00	42 - 1	90105-102A6	22 - 12		27 - 3	90160-05013	9 - 10	90201-164H4	22 - 9	90387-06024	6 - 22
1RC-84314-00	42 - 3	90105-10349	19 - 4		27 - 10	90164-05001	41 - 2	90201-17018	35 - 5	90387-06026	24 - 16
1RC-84347-00	42 - 4	90105-10445	2 - 21		27 - 20	90167-05076	21 - 26	90201-177G4	18 - 8	90387-06057	35 - 47
1TP-84347-00	43 - 9	90105-10638	30 - 16		27 - 27	90167-05079	42 - 12	90201-18021	31 - 29		36 - 28
B4C-84359-00	42 - 7		30 - 29	90111-05011	21 - 9	90170-06026	35 - 39	90201-20008	16 - 43	90387-06130	6 - 30

NUMERICAL INDEX

PART NO.	REF. NO.	PART NO.	REF. NO.	PART NO.	REF. NO.	PART NO.	REF. NO.	PART NO.	REF. NO.	PART NO.	REF. NO.
90387-06136	26 - 4	90450-35001	5 - 12	90467-170A6	5 - 23	90520-20003	19 - 14	92907-08600	5 - 27	93440-64199	16 - 20
90387-06153	20 - 3		6 - 12	90467-17128	9 - 22	90520-20004	19 - 13	93102-12106	18 - 11	93450-19052	2 - 9
90387-06170	42 - 9	90450-56011	9 - 2	90467-290A0	5 - 11	91312-04025	45 - 36	93102-15212	5 - 31	93501-04011	1 - 7
90387-06287	26 - 11		9 - 13		5 - 13	91312-05010	26 - 19	93102-25017	29 - 4		35 - 56
90387-062M9	19 - 45	90450-56012	9 - 3		6 - 11	91312-05020	46 - 2	93102-28022	31 - 3		36 - 37
90387-06300	9 - 18	90462-10064	12 - 20	90468-15139	33 - 6	91312-06014	26 - 15	93102-40030	16 - 21	93603-12007	5 - 39
90387-06301	42 - 18	90464-04001	47 - 8	90480-01558	27 - 17	91312-06016	46 - 13	93106-22019	22 - 4	93605-10090	2 - 18
90387-06344	22 - 27	90464-07009	37 - 27		27 - 34	91312-06025	39 - 10	93106-40013	31 - 13	93900-00030	29 - 6
90387-06372	19 - 23	90464-07014	37 - 25		28 - 10	91312-06030	8 - 9	93108-35004	22 - 6		31 - 8
	20 - 15	90464-07M40	6 - 27	90480-01559	21 - 11	91314-06014	5 - 7	93109-17071	22 - 16	94112-17121	29 - 5
	35 - 43		45 - 15		21 - 23	91314-08030	24 - 5		22 - 23	94118-17080	31 - 7
90387-067V1	43 - 3	90464-10233	47 - 11		27 - 42		25 - 42	93210-04092	12 - 3	94581-79060	7 - 4
90387-06M60	47 - 3	90464-12013	47 - 7	90480-10016	43 - 6	91314-08040	25 - 19	93210-07540	12 - 15	94582-40108	31 - 21
90387-07042	27 - 40	90464-13073	45 - 25	90480-12015	42 - 19	91314-10035	24 - 6	93210-12790	12 - 6	94591-61134	4 - 12
90387-07391	6 - 6	90464-14010	33 - 14	90480-12023	43 - 12	91317-03006	6 - 9	93210-15566	46 - 12	94701-00436	1 - 9
	28 - 6		45 - 19	90480-12237	28 - 21	91317-05010	26 - 22	93210-16325	12 - 9	95022-06008	45 - 6
90387-08088	21 - 4		45 - 24	90480-12314	27 - 5	91317-05040	33 - 10	93210-207A0	7 - 8	95022-06010	5 - 4
	21 - 16		45 - 26		27 - 22	91317-06020	18 - 15	93210-21001	46 - 5		36 - 4
90387-1001B	19 - 20	90464-17008	37 - 22	90480-13001	43 - 4	91380-06012	45 - 16	93210-235A1	5 - 2	95022-06025	45 - 30
90387-10050	35 - 6	90464-18002	20 - 8	90480-13010	7 - 9	91401-20012	37 - 9		5 - 6	95022-08035	24 - 12
90387-10107	27 - 16		34 - 26	90480-14003	35 - 46	91401-25015	35 - 59	93210-27194	13 - 20	95027-06010	19 - 47
	27 - 33	90464-18007	45 - 18		36 - 27		36 - 40	93210-33786	5 - 15	95027-06020	44 - 5
90387-1012A	22 - 17	90464-18011	45 - 20	90480-14100	20 - 10	91402-25015	35 - 20	93210-357A3	13 - 3	95302-08600	31 - 25
	23 - 4	90464-20191	45 - 17		21 - 10		36 - 7	93306-00006	14 - 8	95314-06700	35 - 40
90387-17017	29 - 8	90464-25004	24 - 19		21 - 22	91701-08040	35 - 19	93306-00106	5 - 33	95602-05200	20 - 26
90387-20035	31 - 20		33 - 15	90480-14229	47 - 2		36 - 6		15 - 8		35 - 15
90387-20036	31 - 19		45 - 27	90480-14452	27 - 41	91702-08040	35 - 58	93306-00416	31 - 4		43 - 10
90387-21003	16 - 10	90464-25160	19 - 26	90480-14604	28 - 5		36 - 39	93306-20352	29 - 3	95602-10200	22 - 14
90387-25008	16 - 39	90464-30009	47 - 12	90480-15001	9 - 16	91808-16023	1 - 3	93306-20464	16 - 14		23 - 3
90387-250R3	16 - 3	90464-45003	19 - 49	90480-15014	9 - 17		1 - 4		16 - 44		23 - 6
90387-28004	16 - 30	90464-65001	45 - 22	90480-15363	6 - 5	92012-06010	19 - 18	93306-20480	31 - 2		31 - 16
	16 - 34	90465-08045	13 - 16	90480-16003	26 - 10		37 - 32	93306-205B5	31 - 11	95602-12200	22 - 21
90387-30012	16 - 19		36 - 3	90480-17007	27 - 15	92012-06016	47 - 15	93306-20663	16 - 18	95607-06200	44 - 4
90387-31003	16 - 23	90465-13275	20 - 11		27 - 32	92012-06020	35 - 44	93310-232R9	15 - 12	95617-06100	34 - 8
90401-10020	37 - 28	90465-13M24	46 - 21	90480-30167	19 - 32	92012-06040	47 - 14	93315-21570	5 - 30	95702-06500	19 - 34
90401-10042	34 - 20	90467-08003	6 - 25	90501-06022	17 - 3	92014-06012	35 - 31	93315-31758	22 - 15		28 - 15
90401-10172	34 - 19	90467-08075	6 - 17	90501-12743	35 - 55	92014-06014	47 - 6	93317-11096	5 - 29		46 - 29
	37 - 30		6 - 24		36 - 36		47 - 10		14 - 7	95707-05500	37 - 21
90401-20009	8 - 3	90467-090A2	10 - 17	90501-22721	2 - 17	92014-06016	22 - 32	93317-11295	18 - 10	95707-06500	46 - 25
90413-06031	10 - 16		26 - 26	90501-230E4	15 - 9	92017-06010	19 - 37	93317-22262	22 - 3	95812-06020	5 - 16
90430-06014	5 - 5		26 - 28	90506-18021	18 - 1		22 - 33	93317-31771	22 - 22	95812-06040	7 - 3
90430-08143	13 - 5		26 - 31	90506-23008	36 - 23		26 - 39	93399-99931	24 - 1		12 - 17
90430-10004	46 - 8		26 - 33	90506-23018	35 - 9	92017-08012	13 - 4	93399-99932	25 - 41	95812-06060	12 - 18
90430-10005	34 - 21		26 - 37	90508-18056	35 - 21	92902-04100	34 - 14	93440-25186	16 - 5	95812-08065	12 - 16
	37 - 29	90467-11044	37 - 16		36 - 8	92902-04600	34 - 15		16 - 7	95817-06020	5 - 19
	37 - 31	90467-13083	9 - 15	90508-18132	15 - 19	92902-08600	31 - 26	93440-31187	16 - 25		47 - 4
90445-08020	6 - 15	90467-160A2	9 - 23	90508-29040	18 - 5	92902-10200	24 - 8		16 - 27	95817-06025	9 - 19
90445-10064	6 - 26	90467-170A6	5 - 21	90520-01004	19 - 27	92907-05600	34 - 29		16 - 36	95817-08100	26 - 8

NUMERICAL INDEX

PART NO.	REF. NO.	PART NO.	REF. NO.	PART NO.	REF. NO.	PART NO.	REF. NO.	PART NO.	REF. NO.	PART NO.	REF. NO.
95D02-06010	35 - 50										
	36 - 31										
95D07-06012	19 - 44										
95D32-06010	28 - 11										
95D32-06012	19 - 22										
95D34-06016	11 - 9										
95D37-06025	24 - 17										
97027-05012	34 - 28										
98502-04012	34 - 13										
98502-05012	26 - 6										
98502-06012	10 - 8										
98507-04010	44 - 10										
98507-04020	44 - 15										
98507-04025	44 - 13										
98507-04030	44 - 16										
98704-03020	44 - 9										
99001-07600	5 - 28										
99002-10600	18 - 13										
99009-10400	15 - 21										
99009-12400	5 - 36										
99009-15500	7 - 2										
99009-17400	18 - 9										
99530-08012	13 - 7										
	13 - 14										
99530-10014	12 - 4										
99530-10114	1 - 15										