



PARTS CATALOGUE

T115FSEC (2WB4) MALAYSIA



1S2WB-440E1

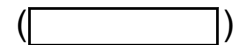

T115FSEC
PARTS CATALOGUE
©2017 by Yamaha Motor Co., Ltd.
1st edition, February 2017
All rights reserved.
Any reprinting or unauthorized use
without the written permission of
Yamaha Motor Co., Ltd.
is expressly prohibited.
Printed in Japan.

FOREWORD

This Parts Catalogue is related to the parts for the model(s) on the cover page. When you are ordering replacement parts, please refer to this Parts Catalogue and quote both part numbers and part names correctly.

1. Modifications or additions which have been made after the issue of the Parts Catalogue will be announced in the Parts News.
It is advisable that you make the necessary corrections to the Parts Catalogue according to the Parts News.

2. Abbreviations

The following abbreviations are used in this Parts Catalogue.

“UR” Use specified parts number.

“UN” Use as many as needed.

“AP” Alternate Parts

“LM” Locally Made (Parts need to be ordered locally)

“F#” Frame No. (Applicable machine No.)

“O/S” Over Size

3. The number of components for assembly

- Parts, which are to be supplied in an assembly, are listed with a dot (.) in front of the part name as shown below.
- The numeral appearing to the right of each component part indicates the quantity of parts for each assembly unit.

PART NO.	DESCRIPTION	Q'TY	REMARKS
2F5-83310-60	FRONT FLASHER LIGHT ASSY	2	
115-83311-60	.BULB (6V-18W)	1	

4. Applicable colours of graphics are represented in the “REMARKS” as shown below.

PART NO.	DESCRIPTION	Q'TY	REMARKS
2N4-24110-00-X5	FUEL TANK COMP.	2	MXR
3J1-24240-10	.GRAPHIC, FUEL TANK	1	FOR MXR

5. Note that the illustrations for reference in finding parts numbers are not to be used for assembling. When assembling, please use the applicable service manual.

6. The asterisk (*) before a reference number indicates modified items after the first edition.

FOREWORD

7. Applicable Serial No.

Frame Serial No.

Engine Serial No.

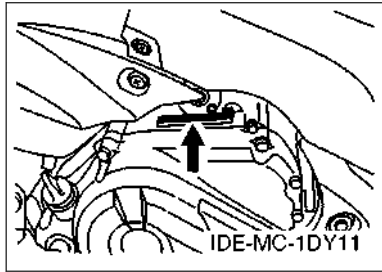
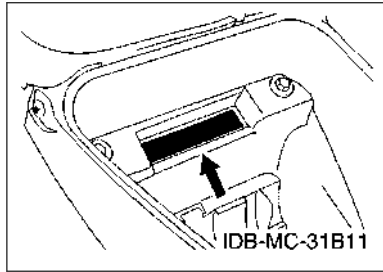

8. Applicable Colour Code (The (*) mark shows Model colour.)

Abbreviation	Colour Name	Colour Code
CIS	CIRCUIT SILVER	00WN
MDS(*)	MIDNIGHT SILVER	007M
RM7(*)	RED METALLIC 7	1218
S3	SILVER 3	0791
SMX	BLACK METALLIC X	0903
VPBC5(*)	VIVID PURPLISH BLUE COCKTAIL 5	1177
YB	YAMAHA BLACK	0033

9. Applicable Starting Serial No.

Frame Serial No.

Serial No.	Name Of Q'ty Column	Model Code

Engine Serial No.

Serial No.	Name Of Q'ty Column	Model Code

CONTENTS

ENGINE

CYLINDER HEAD.....	1
CRANKSHAFT & PISTON.....	2
VALVE.....	3
CAMSHAFT & CHAIN.....	4
OIL PUMP.....	5
INTAKE.....	6
EXHAUST.....	8
CRANKCASE.....	9
CRANKCASE COVER 1.....	10
STARTER.....	11
STARTER CLUTCH.....	12
CLUTCH.....	13
TRANSMISSION.....	15
SHIFT CAM & FORK.....	17
SHIFT SHAFT.....	18

CHASSIS

FRAME.....	19
FENDER.....	20
SIDE COVER.....	21
REAR ARM & SUSPENSION.....	24
STEERING.....	25
FRONT FORK.....	26
FUEL TANK.....	27
SEAT.....	28
FRONT WHEEL FOR CAST WHEEL.....	30
FRONT BRAKE CALIPER.....	31
REAR WHEEL FOR CAST WHEEL.....	32
STEERING HANDLE & CABLE.....	34
FRONT MASTER CYLINDER.....	36
STAND & FOOTREST.....	37
LEG SHIELD.....	39
GENERATOR.....	41
STARTING MOTOR.....	42
FLASHER LIGHT.....	43
METER.....	44
HEADLIGHT.....	45
TAILLIGHT.....	46
HANDLE SWITCH & LEVER.....	47

ELECTRICAL 1.....	48
ELECTRICAL 2.....	49

INDEX

NUMERICAL INDEX.....	50
----------------------	----

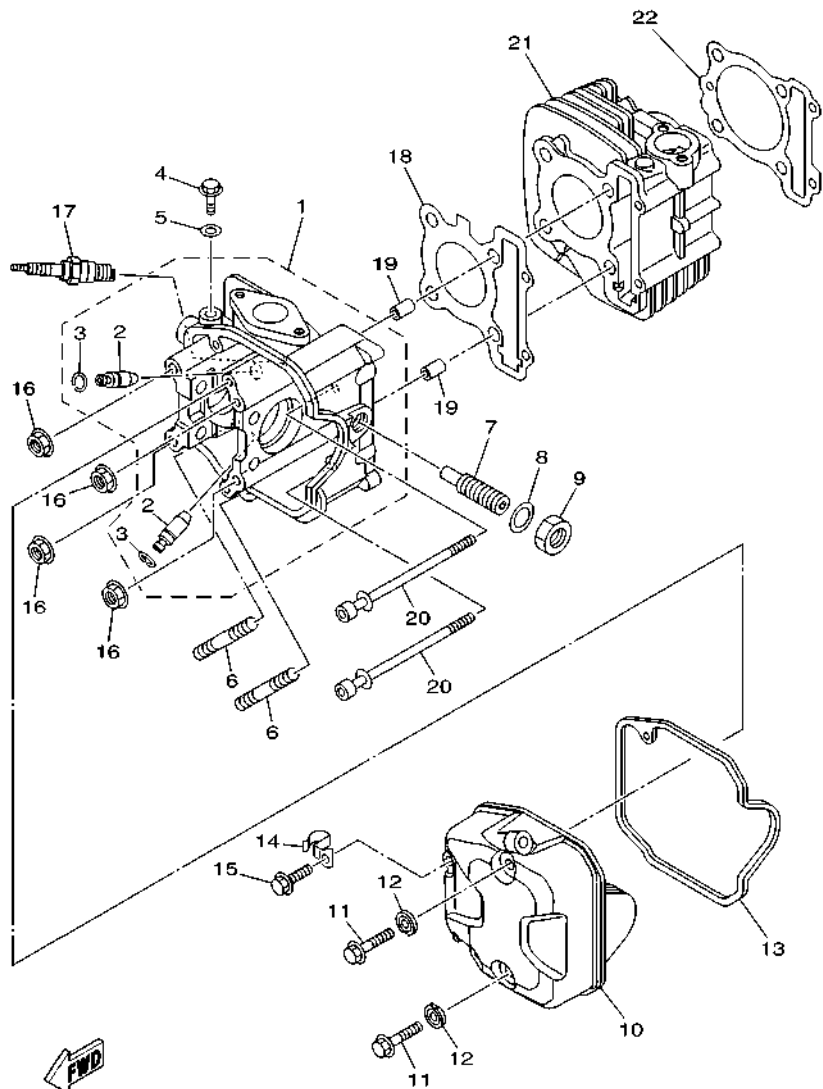

2SU1460-P010

FIG. 1 CYLINDER HEAD

REF. NO.	PART NO.	DESCRIPTION	2WB4				REMARKS
1	1VP-E1102-00	CYLINDER HEAD ASSY	1				
2	54S-E1133-10	.GUIDE, VALVE 1	2				
3	93440-10085	.CIRCLIP	2				
4	95022-06010	BOLT, FLANGE	1				
5	90430-06817	GASKET	1				
6	95612-08625	BOLT, STUD	2				
7	90113-14800	BOLT, SET	1				
8	90430-14043	GASKET	1				
9	95302-14600	NUT, HEXAGON	1				
10	1VP-E1191-20	COVER, CYLINDER HEAD 1	1				
11	95812-06030	BOLT, FLANGE	2				
12	1FC-E1173-00	WASHER, SEALING	2				
13	1FC-E1193-00	GASKET, HEAD COVER 1	1				
14	90462-08800	CLAMP	1				
15	95022-06012	BOLT, FLANGE	1				
16	90179-08518	NUT	4				
17	94700-00372	PLUG, SPARK (NGK CR6HSA)	1				
18	54P-E1181-00	GASKET, CYLINDER HEAD 1	1				
19	91810-14809	PIN, DOWEL	2				
20	90110-06868	BOLT, HEXAGON SOCKET HEAD	2				
21	2SU-E1310-00	CYLINDER	1				
22	1DY-E1351-00	GASKET, CYLINDER	1				

FIG. 2 CRANKSHAFT & PISTON

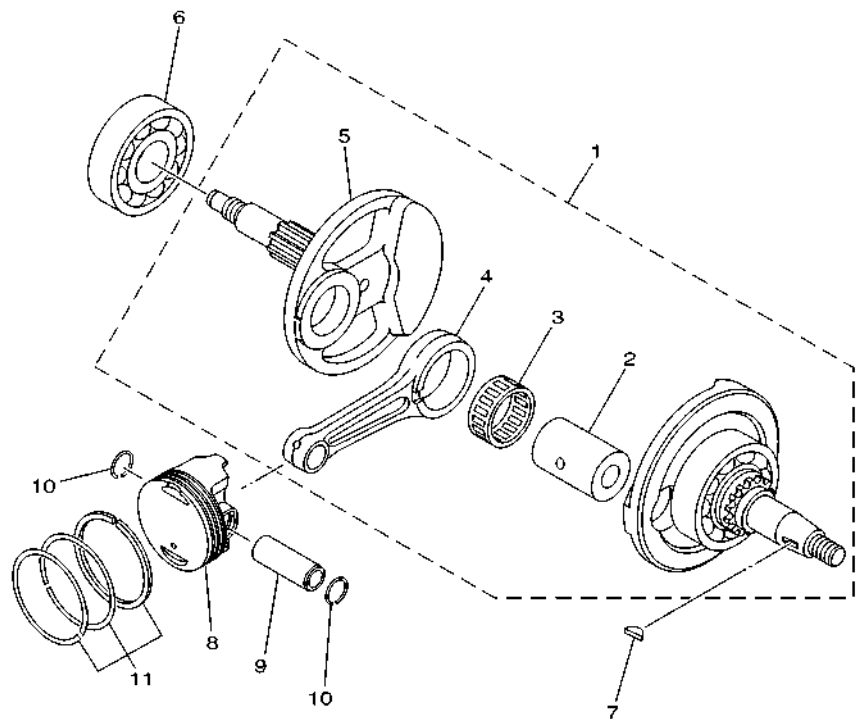

1DY1460-L020

REF. NO.	PART NO.	DESCRIPTION	2WB4				REMARKS
1	1VP-WE140-10	CRANKSHAFT ASSY	1				
2	1DY-E1681-00	.PIN, CRANK 1	1				
3	93310-528YA	.BEARING	1				
4	1DY-E1651-00	.ROD, CONNECTING	1				
5	1VP-E1422-00	.CRANK 2	1				
6	93306-305XA	BEARING	1				
7	90280-03017	KEY, WOODRUFF	1				
8	1DY-E1631-10	PISTON (STD)	1				
	1DY-E1636-09	PISTON (0.50MM O/S)	1				AP
	1DY-E1638-09	PISTON (1.00MM O/S)	1				AP
9	1FC-E1633-00	PIN, PISTON	1				
10	93450-14088	CIRCLIP	2				
11	1DY-E1603-10	PISTON RING SET (STD)	1				
	1DY-E1605-10	PISTON RING SET (0.50MM O/S)	1				AP
	1DY-E1607-10	PISTON RING SET (1.00MM O/S)	1				AP

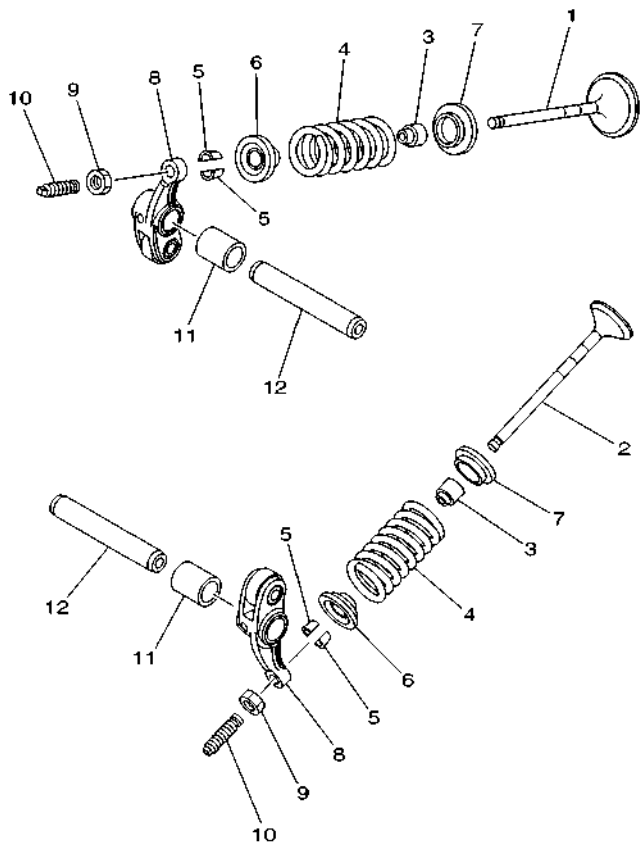
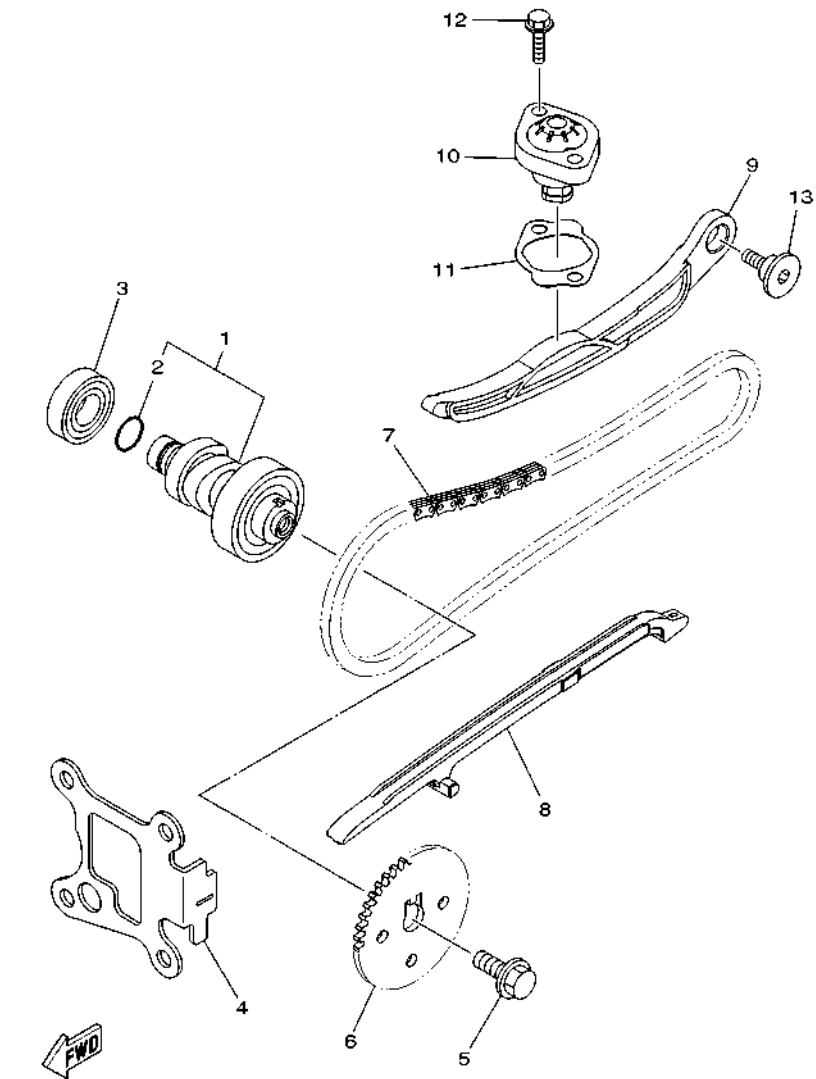

FIG. 3 VALVE

REF. NO.	PART NO.	DESCRIPTION	2WB4				REMARKS
1	2BL-E2111-00	VALVE, INTAKE	1				
2	54S-E2121-00	VALVE, EXHAUST	1				
3	54P-E2119-00	SEAL, VALVE STEM	2				
4	1DY-E2113-00	SPRING, VALVE INNER	2				
5	5TL-E2118-00	LOCK, VALVE SPRING RETAINER	4				
6	54S-E2117-00	RETAINER, VALVE SPRING	2				
7	5P0-E2126-00	SEAT, VALVE SPRING 2	2				
8	2BL-E2151-00	ARM, VALVE ROCKER	2				
9	90170-05803	NUT	2				
10	33S-E2159-10	SCREW, VALVE ADJUSTING	2				UR
	33S-E2159-01	SCREW, VALVE ADJUSTING	2				UR
11	44D-E2662-00	COLLAR 1	2				
12	54P-E2146-00	SHAFT, ROCKER	2				



54S1431-L030



2VP2422-P040

FIG. 4 CAMSHAFT & CHAIN

REF. NO.	PART NO.	DESCRIPTION	2WB4				REMARKS
1	1VP-E2170-00	CAMSHAFT ASSY 1	1				
2	93210-12801	.O-RING	1				
3	93306-002YW	BEARING	1				
4	54P-E111F-00	PLATE	1				
5	90105-088E1	BOLT, FLANGE	1				
6	1DY-E2176-00	SPROCKET, CAM CHAIN	1				
7	94568-H5090	CHAIN	1				
8	54P-E2231-00	GUIDE, STOPPER 1	1				
9	54P-E2241-00	GUIDE, STOPPER 2	1				
10	2SU-E2210-00	TENSIONER ASSY, CAM CHAIN	1				
11	2SU-E2213-00	GASKET, TENSIONER CASE	1				
12	95022-06020	BOLT, FLANGE	2				
13	54P-E2228-00	BOLT	1				UR
	1DR-E2228-00	BOLT	1				UR

FIG. 5 OIL PUMP

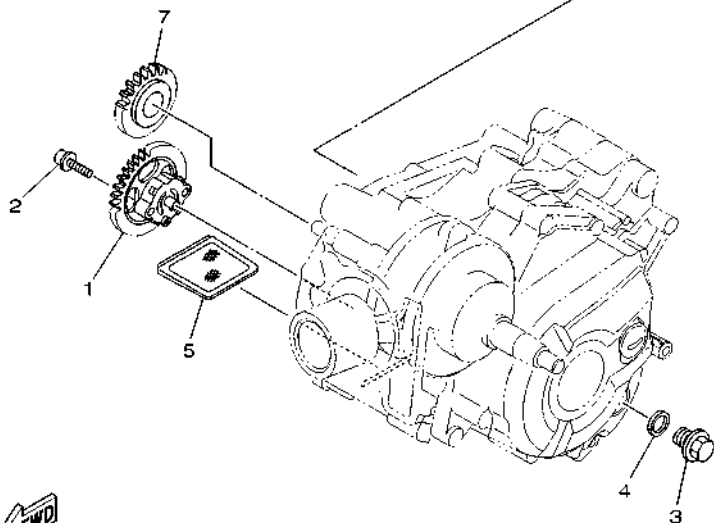
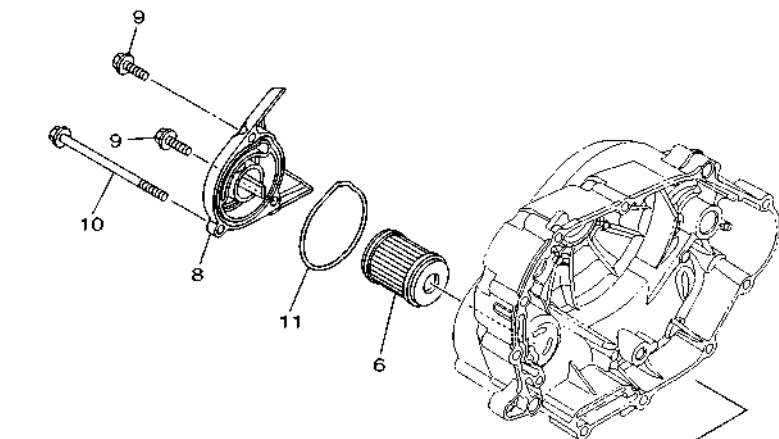

1DY1460-L050

REF. NO.	PART NO.	DESCRIPTION	2WB4				REMARKS
1	1DY-E3300-00	OIL PUMP ASSY	1				
2	90110-05801	BOLT, HEXAGON SOCKET HEAD	2				
3	90340-12808	PLUG, STRAIGHT SCREW	1				
4	4YS-E1198-00	GASKET	1				
5	4LS-E3411-00	STRAINER, OIL	1				
6	38B-E3440-00	ELEMENT ASSY, OIL CLEANER	1				
7	31D-E3324-00	GEAR, PUMP DRIVE	1				
8	1VP-E3447-00	COVER, OIL ELEMENT	1				
9	95022-06020	BOLT, FLANGE	2				
10	95022-06100	BOLT, FLANGE	1				
11	93210-60800	O-RING	1				

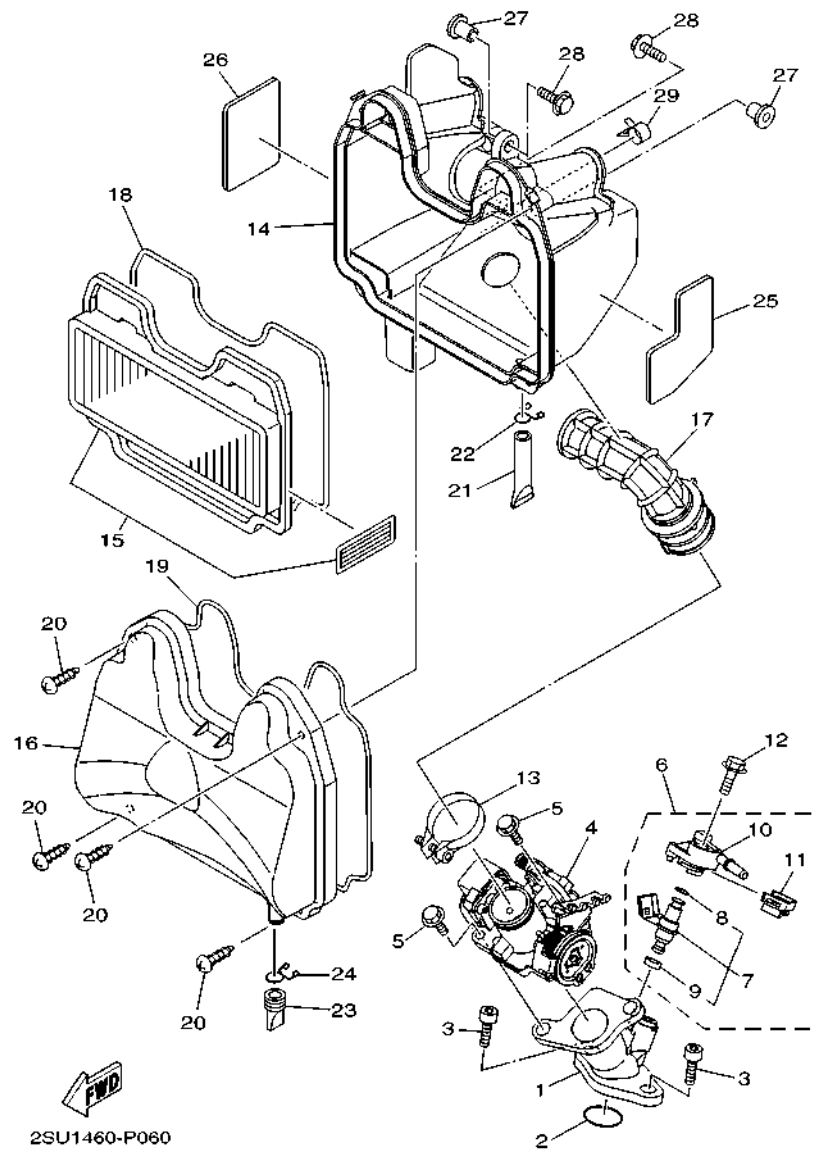
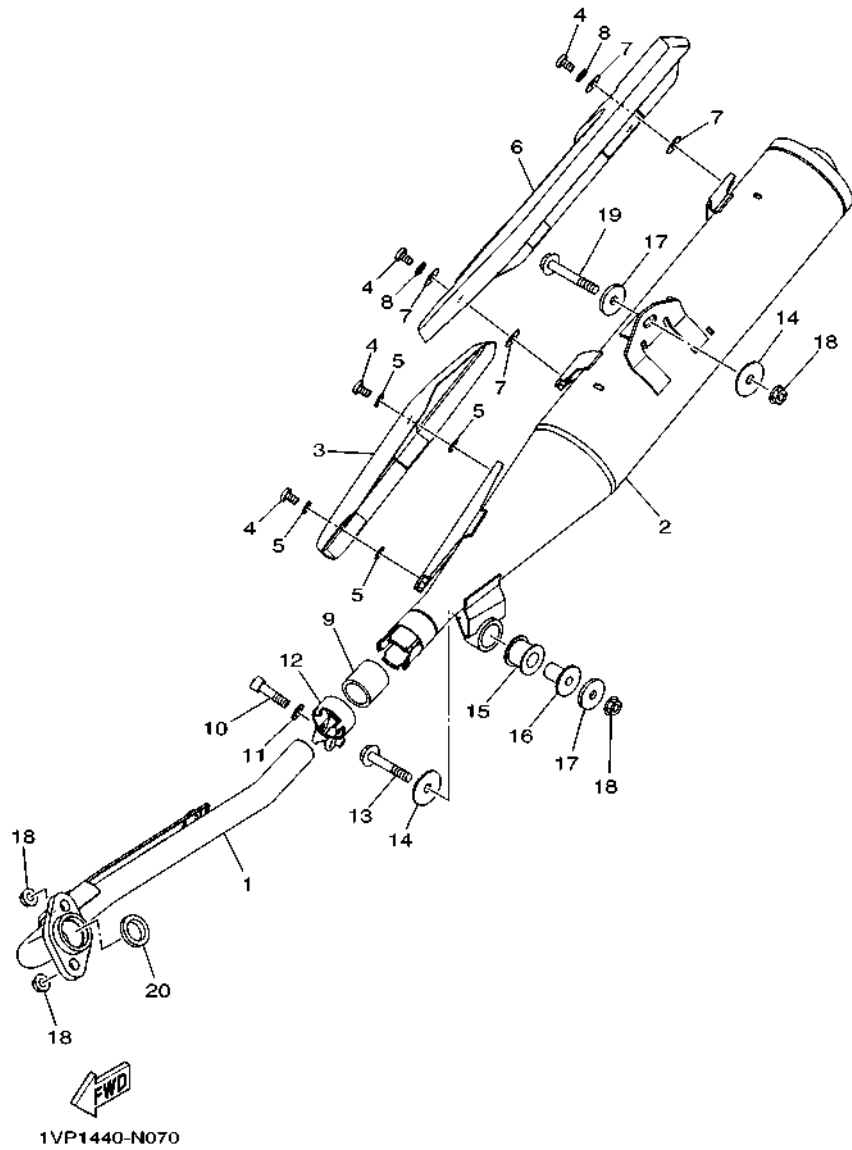

FIG. 6 INTAKE

REF. NO.	PART NO.	DESCRIPTION	2WB4	REMARKS
1	2SU-E3585-00	MANIFOLD	1	
2	93210-30611	O-RING	1	
3	91312-06020	BOLT	2	
4	2SU-E3750-00	THROTTLE BODY ASSY	1	
5	95022-06020	BOLT, FLANGE	2	
6	2SU-E3770-00	INJECTOR ASSY	1	
7	2SU-E3761-00	.INJECTOR	1	
8	2SU-E4147-00	..O-RING	1	
9	2SU-E41A1-00	..SEAL RING	1	
10	2SU-E3938-00	.PIPE	1	
11	1ST-E4137-00	.CLIP	1	
12	95812-06025	BOLT, FLANGE	1	
13	54P-E3575-00	BAND	1	
14	2SU-E4411-00	CASE, AIR CLEANER 1	1	
15	1DY-WE445-00	AIR CLEANER ELEMENT ASSY	1	
16	1DY-E4412-00	CAP, CLEANER CASE 1	1	
17	2SU-E4453-00	JOINT, AIR CLEANER 1	1	
18	1DY-E4462-00	SEAL	1	
19	1DY-E4452-00	SEAL	1	
20	97702-50030	SCREW, TAPPING	4	
21	4ST-E443E-00	PIPE, DRAIN	1	
22	90467-110A3	CLIP	1	
23	5D9-E443G-00	PIPE, DRAIN 2	1	
24	90467-12802	CLIP	1	
25	1DY-E4425-00	DAMPER 1	1	
26	1DY-E4426-00	DAMPER 2	1	
27	90387-06803	COLLAR	2	

FIG. 7 EXHAUST



REF. NO.	PART NO.	DESCRIPTION	2WB4				REMARKS
1	1VP-E4611-00	PIPE, EXHAUST 1	1				
2	2WB-E4711-00	MUFFLER 1	1				
3	1VP-E4728-00	PROTECTOR, MUFFLER 2	1				
4	98980-06012	SCREW, BIND	4				
5	4BD-14766-00	WASHER, PROTECTOR	4				
6	1VP-E4718-00	PROTECTOR, MUFFLER 1	1				
7	5TF-14766-00	WASHER, PROTECTOR	4				
8	90201-06078	WASHER, PLATE	2				
9	44D-E4714-00	GASKET, MUFFLER	1				
10	91312-08035	BOLT	1				
11	90201-08043	WASHER, PLATE	1				
12	44P-E4715-00	BAND, MUFFLER	1				
13	95802-08040	BOLT, FLANGE	1				
14	90201-08116	WASHER, PLATE	2				
15	29B-E4747-00	DAMPER, MUFFLER	1				
16	90387-08830	COLLAR	1				
17	90201-08117	WASHER, PLATE	2				
18	95702-08500	NUT, FLANGE	4				
19	95822-08045	BOLT, FLANGE	1				
20	10C-E4613-00	GASKET, EXHAUST PIPE	1				

FIG. 8 CRANKCASE

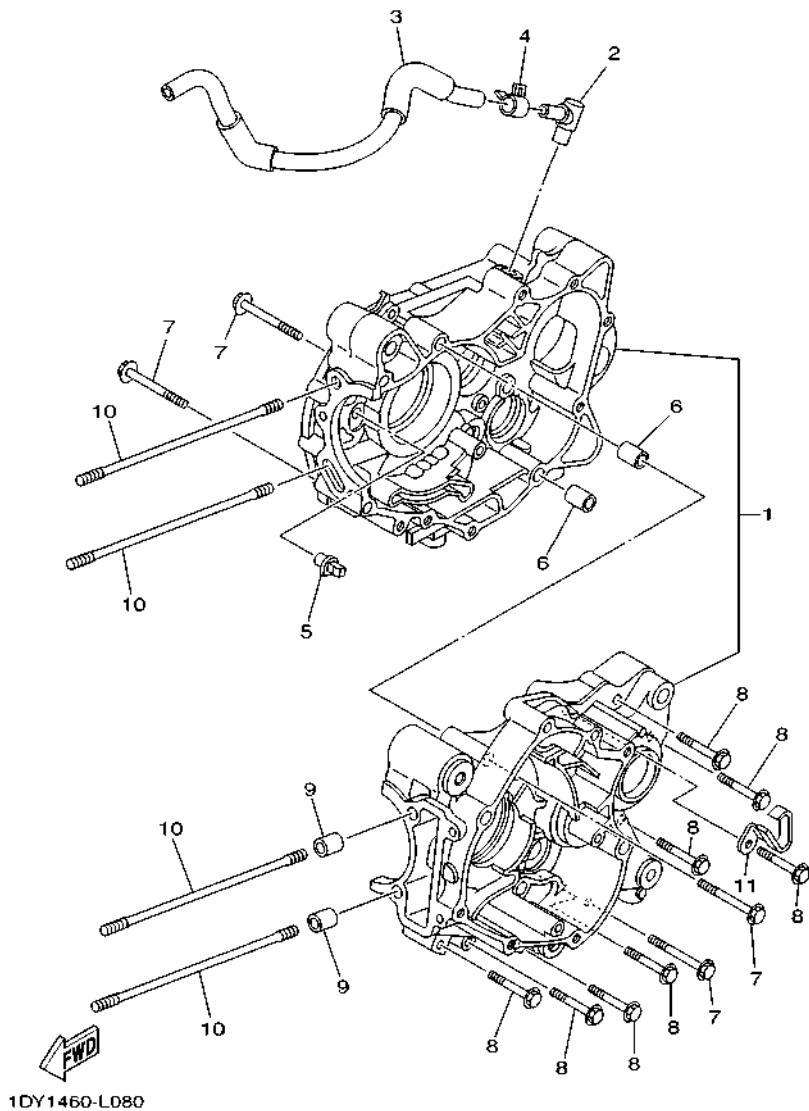

REF. NO.	PART NO.	DESCRIPTION	2WB4				REMARKS
1	1VP-E5150-00	CRANKCASE ASSY	1				
2	4ST-E5371-00	BREATHER	1				UR
	5VT-E5371-00	BREATHER	1				UR
3	1DY-E1166-00	PIPE, BREATHER 1	1				
4	90467-13808	CLIP	1				
5	16S-E5155-00	NOZZLE 3	1				
6	91810-14809	PIN, DOWEL	2				
7	95022-06055	BOLT, FLANGE	4				
8	95022-06040	BOLT, FLANGE	8				
9	91810-14809	PIN, DOWEL	2				
10	90116-08843	BOLT, STUD	4				
11	90462-08818	CLAMP	1				

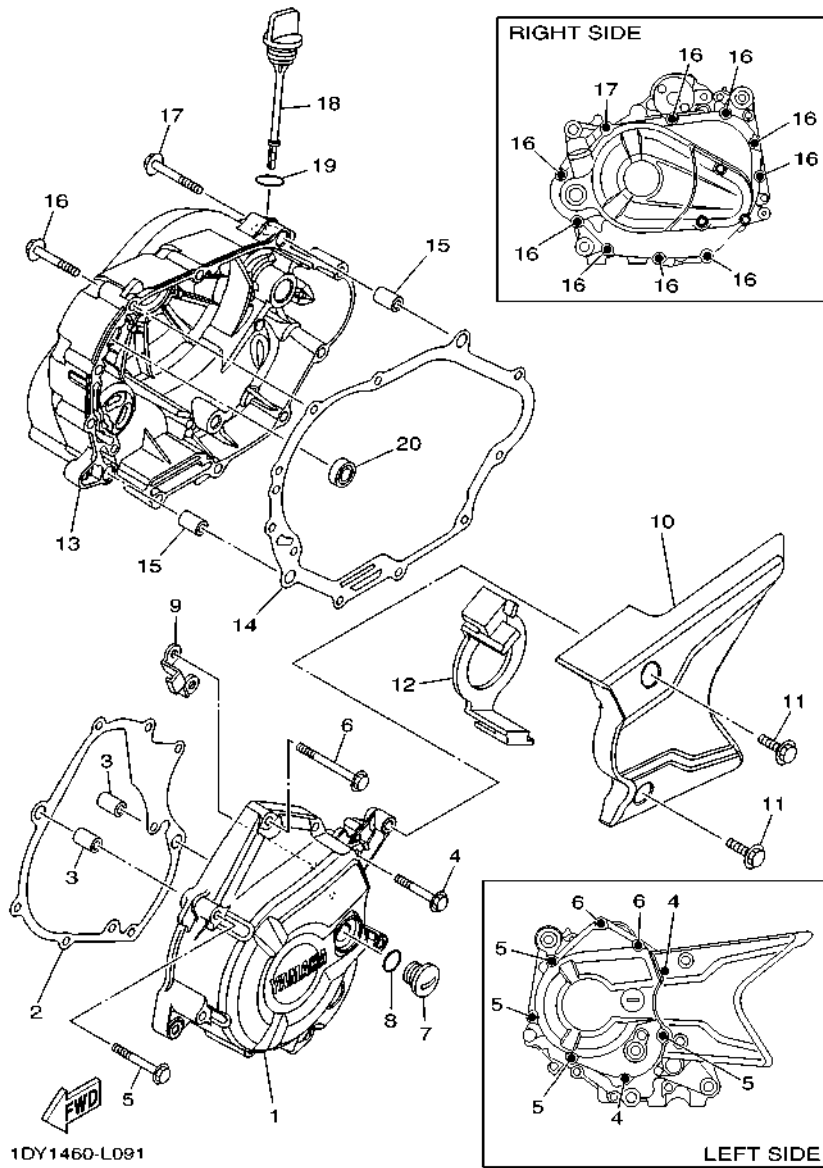
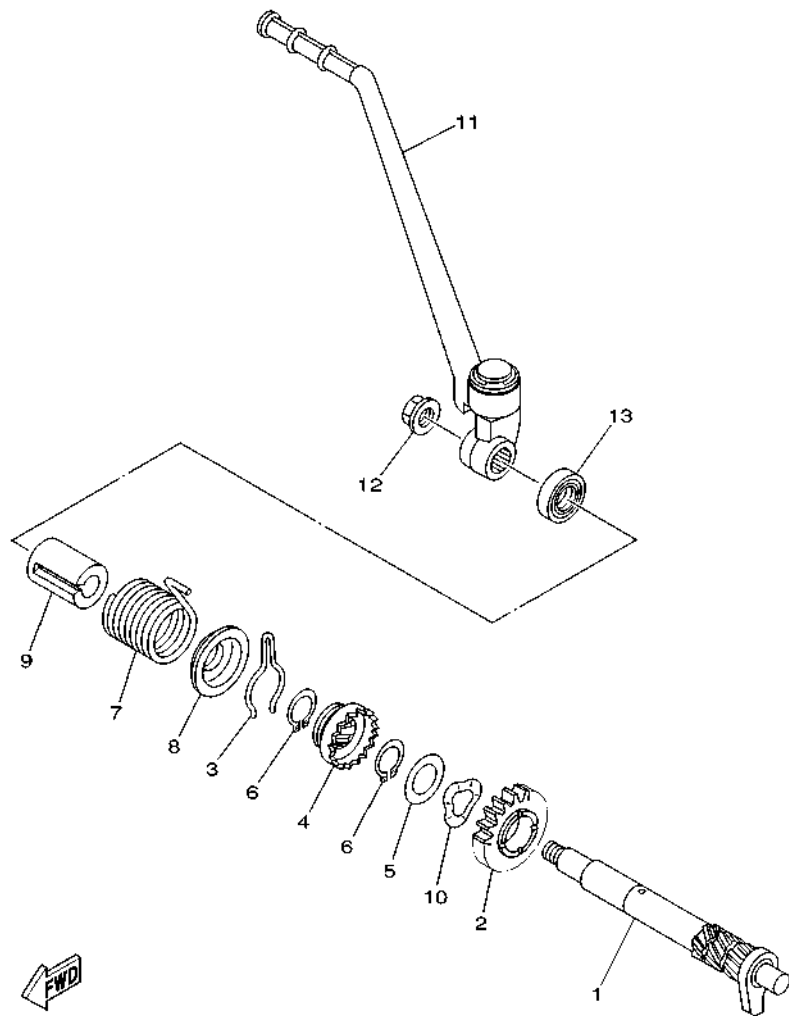

FIG. 9 CRANKCASE COVER 1

REF. NO.	PART NO.	DESCRIPTION	2WB4	REMARKS
1	1VP-E5411-00	COVER, CRANKCASE 1	1	
2	1DY-E5451-00	GASKET, CRANKCASE COVER 1	1	
3	91810-14809	PIN, DOWEL	2	
4	90105-06893	BOLT, FLANGE	2	
5	95022-06050	BOLT, FLANGE	4	
6	95022-06060	BOLT, FLANGE	2	
7	90340-14812	PLUG, STRAIGHT SCREW	1	
8	93210-148F8	O-RING	1	
9	31B-E5113-00	PLATE	1	
10	1VP-E5418-00	COVER, CHAIN CASE	1	
11	95802-06016	BOLT, FLANGE	2	
12	16S-E5377-01	GUIDE, INLET	1	
13	1VP-E5421-00	COVER, CRANKCASE 2	1	
14	5D9-E5461-10	GASKET, CRANKCASE COVER 2	1	
15	91810-14809	PIN, DOWEL	2	
16	95022-06040	BOLT, FLANGE	9	
17	95022-06050	BOLT, FLANGE	1	
18	5D9-E5362-10	PLUG, OIL LEVEL	1	
19	93210-19804	O-RING	1	
20	93101-10804	OIL SEAL	1	UR
	93101-10843	OIL SEAL	1	UR

FIG. 10 STARTER



35D3460-K110

REF. NO.	PART NO.	DESCRIPTION	2WB4				REMARKS
1	5D9-E5661-20	AXLE, KICK	1				
2	5D9-E5641-00	GEAR, KICK	1				
3	90468-23194	CLIP	1				
4	5D9-E5671-10	WHEEL, RATCHET	1				
5	4WH-E5644-00	SHIM	1				
6	99009-19400	CIRCLIP	2				
7	90508-26808	SPRING, TORSION	1				
8	5D9-E5645-10	PLATE	1				
9	5D9-E5664-20	GUIDE, SPRING	1				
10	90206-19802	WASHER, WAVE	1				
11	1VP-E5620-00	KICK CRANK ASSY	1				
12	90179-10803	NUT	1				
13	93102-16801	OIL SEAL	1				

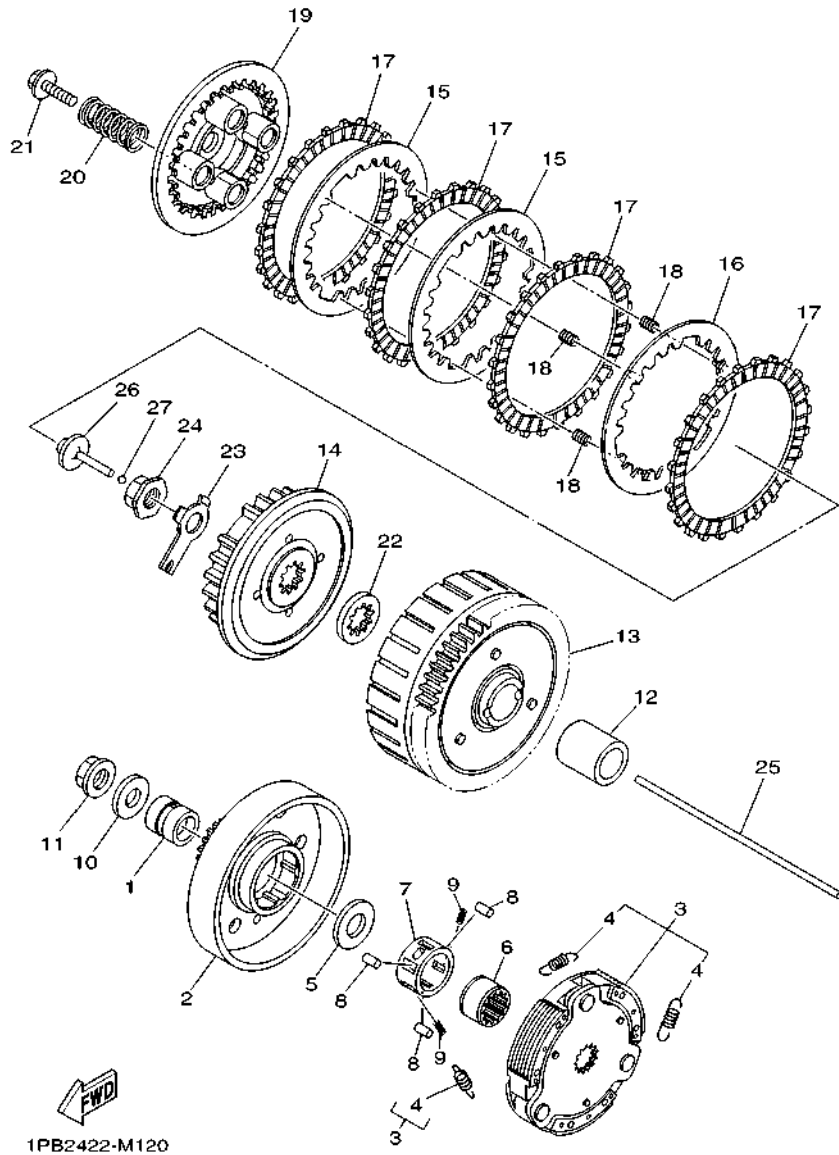

1PB2422-M120

FIG. 12 CLUTCH

REF. NO.	PART NO.	DESCRIPTION	2WB4				REMARKS
1	90387-16814	COLLAR	1				
2	1VP-E6611-10	CLUTCH HOUSING COMP.	1				
3	1VP-E6620-10	CLUTCH CARRIER ASSY	1				
4	1DY-E6626-00	.SPRING, CLUTCH WEIGHT 1	3				
5	90201-167P7	WASHER, PLATE	1				
6	5LM-E6512-00	BOSS, CLUTCH HOUSING	1				
7	5D9-E6586-00	CAGE	1				
8	93606-10800	PIN, DOWEL	3				
9	90501-04805	SPRING, COMPRESSION	2				
10	90201-12820	WASHER, PLATE	1				
11	90179-12802	NUT	1				
12	90387-20810	COLLAR	1				
13	1VP-E6150-00	PRIMARY DRIVEN GEAR COMP.	1				
14	1FD-E6371-00	BOSS, CLUTCH	1				
15	1FD-E6324-00	PLATE, CLUTCH 1	2				
16	1FD-E6350-00	PRESSURE PLATE ASSY	1				
17	1FD-E6321-00	PLATE, FRICTION	4				
18	1FD-E6383-00	SPRING, CUSHION	3				
19	1FD-E6351-00	PLATE, PRESSURE 1	1				
20	1PB-E6333-00	SPRING, CLUTCH 1	4				
21	1PB-E6194-00	BOLT, HEXAGON WITH WASHER	4				
22	1PB-E6628-00	WASHER	1				
23	1FD-E6135-00	WASHER, LOCK	1				
24	90179-14001	NUT	1				
25	5D9-E6357-00	ROD, PUSH 2	1				UR
	1FC-E6357-00	ROD, PUSH 2	1				UR
26	5YP-E6356-00	ROD, PUSH 1	1				UR

FIG. 13 TRANSMISSION

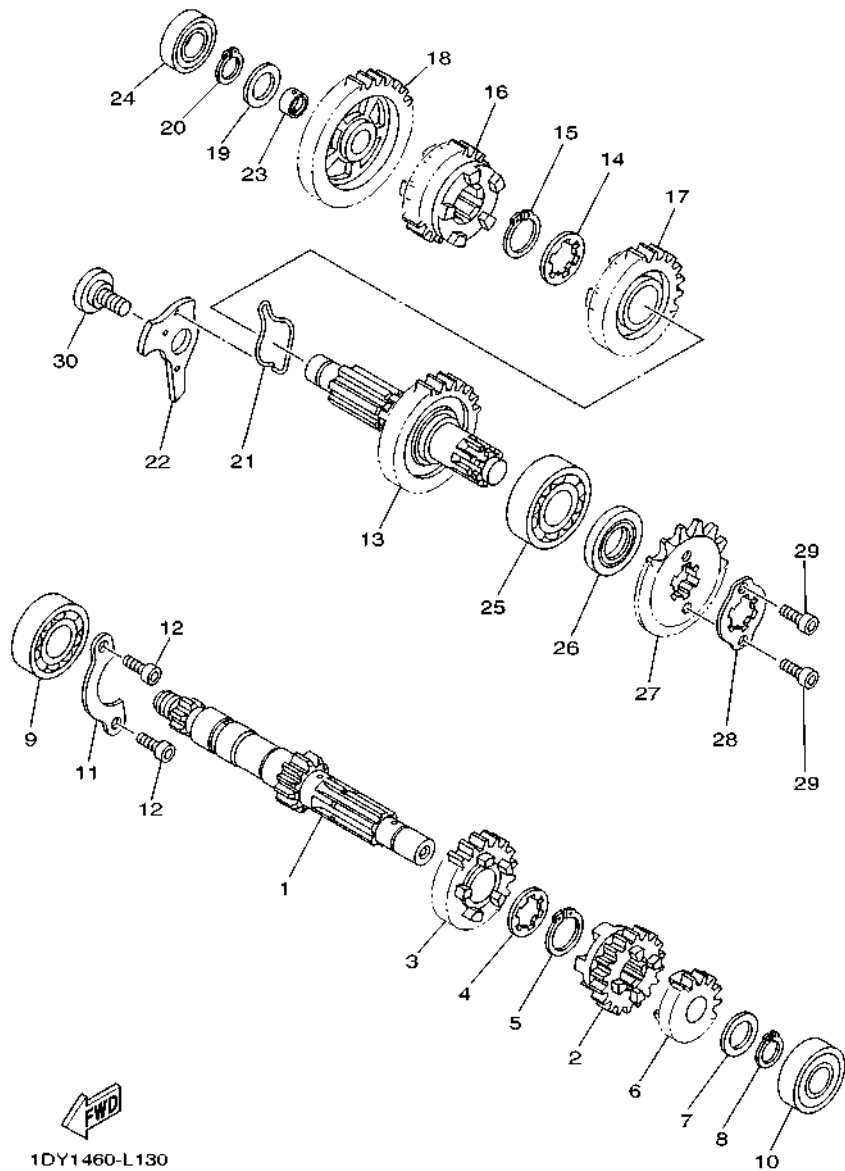

1DY1460-L130

REF. NO.	PART NO.	DESCRIPTION	2WB4				REMARKS
1	1DY-E7411-00	AXLE, MAIN (12T)	1				
2	1DY-E7131-00	GEAR, 3RD PINION (17T)	1				
3	1DY-E7141-00	GEAR, 4TH PINION (22T)	1				
4	90209-17285	WASHER	1				
5	93410-20038	CIRCLIP	1				
6	1DY-E7121-00	GEAR, 2ND PINION (16T)	1				UR
	1DY-E7121-10	GEAR, 2ND PINION (16T)	1				UR
7	90201-15700	WASHER, PLATE	1				
8	99009-15400	CIRCLIP	1				
9	93306-054X1	BEARING	1				UR
	93306-054Y2	BEARING	1				UR
10	93306-252XR	BEARING	1				
11	3C1-E7471-00	PLATE, COVER	1				
12	91312-06012	BOLT	2				
13	1DY-E7402-10	DRIVE AXLE ASSY	1				
14	90209-18208	WASHER	1				
15	93410-22039	CIRCLIP	1				
16	1FD-E7241-00	GEAR, 4TH WHEEL (23T)	1				
17	1DY-E7231-00	GEAR, 3RD WHEEL (23T)	1				
18	1DY-E7211-00	GEAR, 1ST WHEEL (34T)	1				UR
	1DY-E7211-10	GEAR, 1ST WHEEL (34T)	1				UR
19	90201-15700	WASHER, PLATE	1				
20	99009-15400	CIRCLIP	1				
21	1DY-E8545-00	SPRING	1				
22	31B-E8561-00	PLATE, SIDE 1	1				
23	90387-15817	COLLAR	1				
24	93306-002YE	BEARING	1				

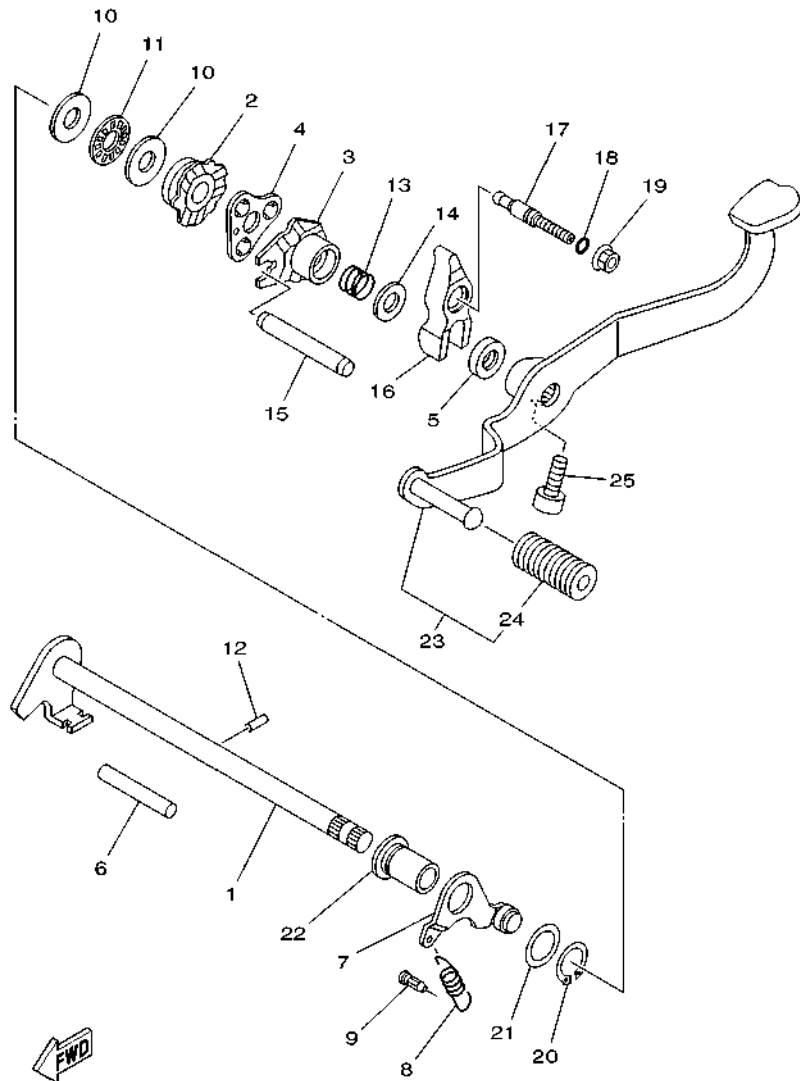

1VP1440-N150

FIG. 15 SHIFT SHAFT

REF. NO.	PART NO.	DESCRIPTION	2WB4				REMARKS
1	1DY-E8101-00	SHIFT SHAFT ASSY	1				
2	1DY-E8179-10	GUIDE	1				
3	1DY-E8172-10	GUIDE, SHIFT	1				
4	5D9-E8181-00	HOLDER, PAWL	1				
5	93102-12891	OIL SEAL	1				
6	93608-50149	PIN, DOWEL	1				
7	1DY-E8140-00	STOPPER LEVER ASSY	1				
8	5D9-E8337-10	SPRING	1				
9	5HV-E6346-00	HOOK, SPRING	1				
10	90201-127F4	WASHER, PLATE	2				
11	93340-212Y2	BEARING	1				
12	93604-10801	PIN, DOWEL	1				
13	90501-125E9	SPRING, COMPRESSION	1				
14	90201-12824	WASHER, PLATE	1				
15	5LM-E8173-00	PIN, SHIFT	1				
16	1VP-E817A-00	ARM, SHIFT 3	1				
17	5D9-E8186-00	SCREW, ADJUSTING	1				
18	93210-068F7	O-RING	1				
19	95702-06500	NUT, FLANGE	1				
20	99009-17400	CIRCLIP	1				
21	90201-178D3	WASHER, PLATE	1				
22	1DY-E8699-00	BOSS 1	1				
23	1VP-E8110-00	SHIFT PEDAL ASSY	1				
24	5H3-E8113-00	.COVER, SHIFT PEDAL	1				
25	91312-08020	BOLT	1				

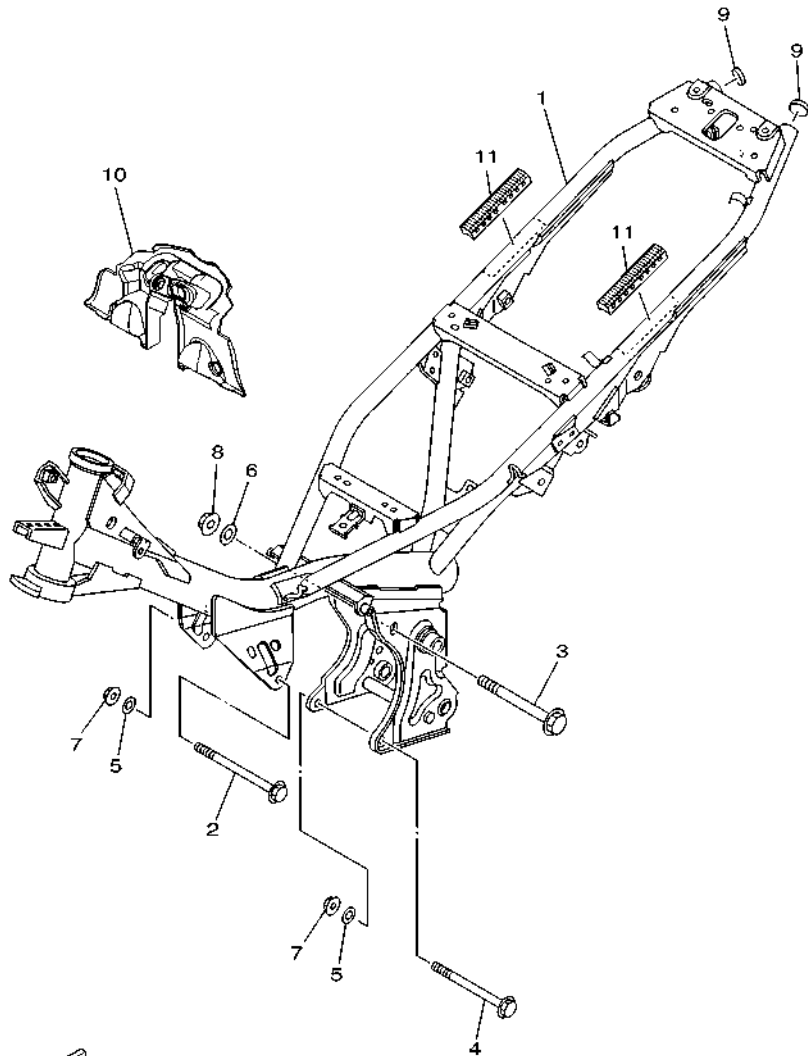

2WB2440-R160

FIG. 16 FRAME

REF. NO.	PART NO.	DESCRIPTION	2WB4				REMARKS
1	1VP-F1110-00	FRAME COMP.	1				
2	90105-088E0	BOLT, FLANGE	1				
3	95812-10120	BOLT, FLANGE	1				
4	90105-088D9	BOLT, FLANGE	1				
5	90201-08043	WASHER, PLATE	2				
6	90201-10035	WASHER, PLATE	1				
7	90179-08818	NUT	2				
8	90179-10024	NUT	1				
9	5TF-F139R-00	COVER 2	2				
10	1VP-F117R-00	COVER 4	1				
11	2SU-F139U-00	DAMPER 2	2				

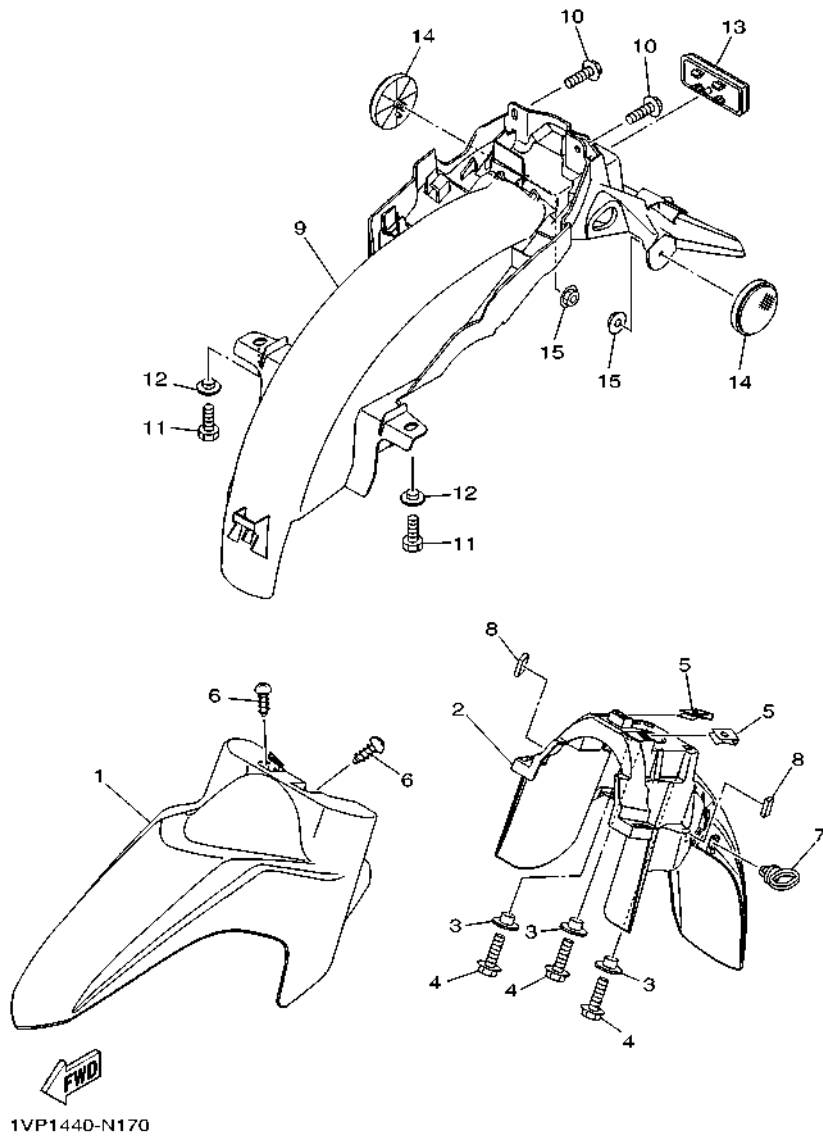

FIG. 17 FENDER

REF. NO.	PART NO.	DESCRIPTION	2WB4	REMARKS
1	1VP-F1511-00-P4	FENDER, FRONT	1	UR FOR RM7
	1VP-F1511-00-7M	FENDER, FRONT	1	UR FOR MDS
	1VP-F1511-00-P7	FENDER, FRONT	1	UR FOR VPBC5
2	1VP-F1556-00	FENDER, FRONT 2	1	
3	90387-06857	COLLAR	3	
4	95822-06020	BOLT, FLANGE	3	
5	90183-05807	NUT, SPRING	2	
6	97702-50012	SCREW, TAPPING	2	
7	15K-F1518-00	HOLDER, CABLE	1	
8	5LL-F8371-00	DAMPER	2	
9	1VP-F1611-00	FENDER, REAR	1	
10	90119-068B7	BOLT, WITH WASHER	2	
11	97027-06016	BOLT, HEXAGON	2	
12	90387-07819	COLLAR	2	
13	54P-H5130-00	REAR REFLECTOR ASSY	1	
14	1CJ-H5111-00	REFLECTOR, FRONT 1	2	
15	95702-06500	NUT, FLANGE	2	

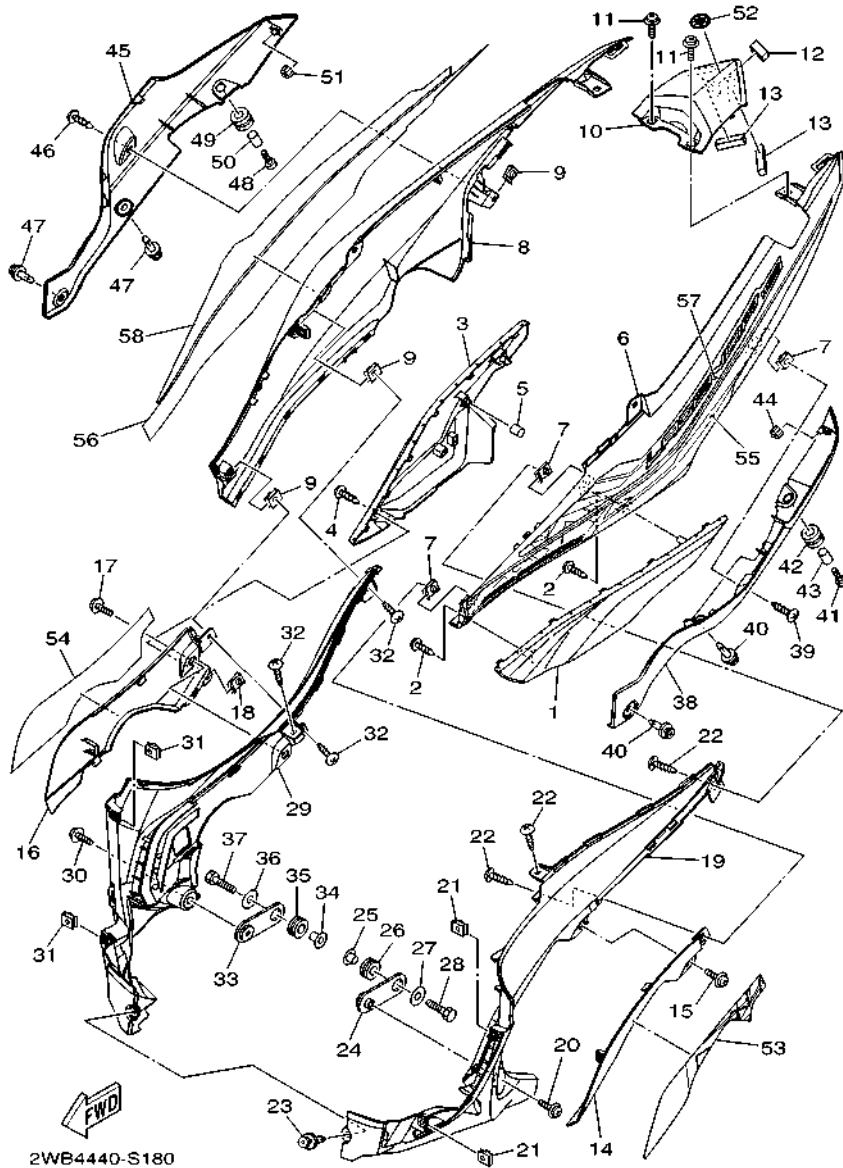
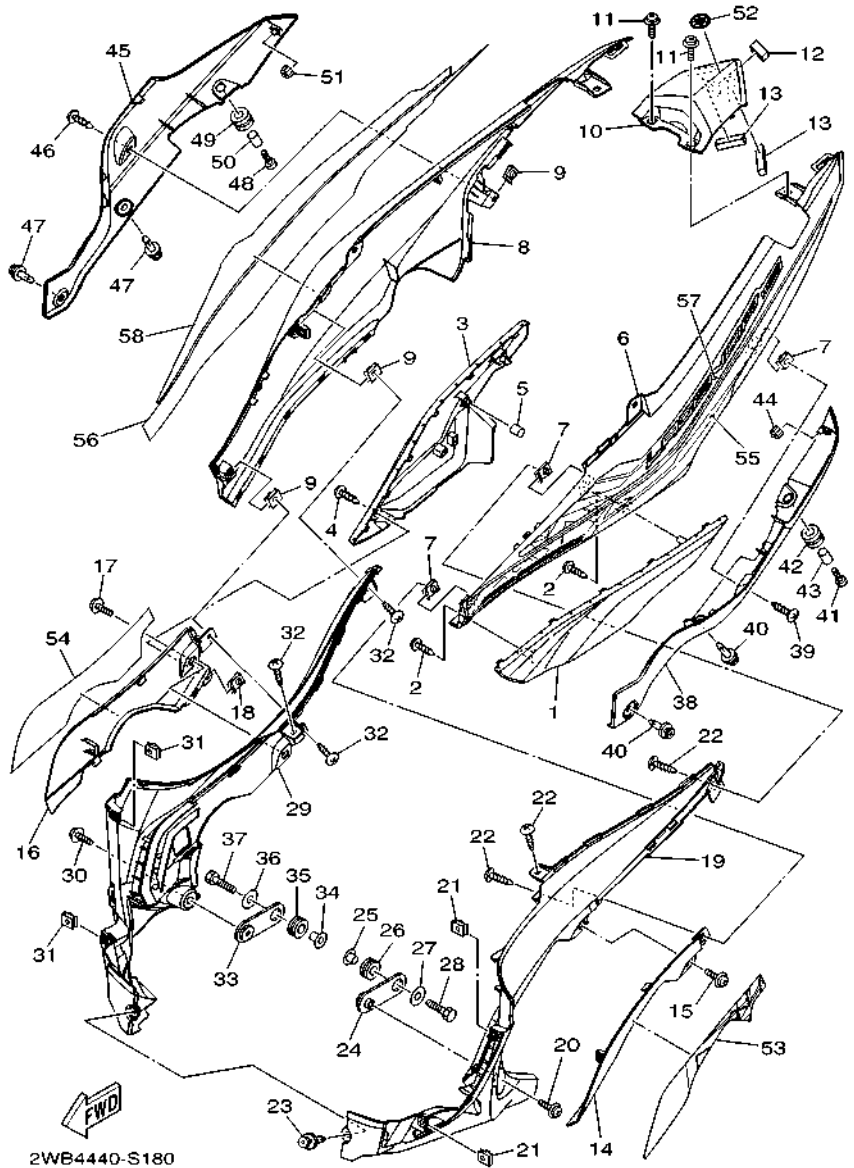

FIG. 18 SIDE COVER

REF. NO.	PART NO.	DESCRIPTION	2WB4	REMARKS
1	1VP-F1711-00	COVER, SIDE 1	1	
2	97702-50016	SCREW, TAPPING	2	
3	1VP-F1721-00	COVER, SIDE 2	1	
4	97707-50016	SCREW, TRUSS HEAD TAPPING	1	
5	3YR-F622F-00	DAMPER, LOCATING 1	1	
6	1VP-F1731-00-7M	COVER, SIDE 3	1	MDS FOR RM7
	1VP-F1731-00-P0	COVER, SIDE 3	1	SMX FOR MDS,VPBC5
7	90183-05807	NUT, SPRING	3	
8	1VP-F1741-00-7M	COVER, SIDE 4	1	MDS FOR RM7
	1VP-F1741-00-P0	COVER, SIDE 4	1	SMX FOR MDS,VPBC5
9	90183-05807	NUT, SPRING	3	
10	1VP-F171E-00-7M	COVER, SIDE 5	1	MDS FOR RM7
	1VP-F171E-00-P0	COVER, SIDE 5	1	SMX FOR MDS,VPBC5
11	90159-06810	SCREW, WITH WASHER	2	
12	1DY-F7414-00	DAMPER, FOOTREST	1	
13	90520-06807	DAMPER, PLATE	2	
14	1VP-F172A-00-7M	PANEL 1	1	MDS FOR RM7
	1VP-F172A-00-P0	PANEL 1	1	SMX FOR MDS,VPBC5
15	90159-06067	SCREW, WITH WASHER	1	
16	1VP-F172F-00-7M	PANEL 2	1	MDS FOR RM7
	1VP-F172F-00-P0	PANEL 2	1	SMX FOR MDS,VPBC5
17	90159-06067	SCREW, WITH WASHER	1	
18	90183-05807	NUT, SPRING	1	
19	1VP-F8385-00	COVER, UNDER	1	
20	90159-06067	SCREW, WITH WASHER	1	
21	90183-05807	NUT, SPRING	2	
22	97702-50016	SCREW, TAPPING	3	



2WB4440-S180

FIG. 18 SIDE COVER

REF. NO.	PART NO.	DESCRIPTION	2WB4				REMARKS
23	90269-06812	RIVET	1				
24	1DY-F8321-00	STAY 1	1				
25	90387-06841	COLLAR	1				
26	90480-13815	GROMMET	1				
27	90201-06882	WASHER, PLATE	1				
28	97002-06020	BOLT	1				
29	1VP-F8395-00	COVER, UNDER 2	1				
30	90159-06067	SCREW, WITH WASHER	1				
31	90183-05807	NUT, SPRING	2				
32	97702-50016	SCREW, TAPPING	3				
33	1DY-F8321-00	STAY 1	1				
34	90387-06841	COLLAR	1				
35	90480-13815	GROMMET	1				
36	90201-06882	WASHER, PLATE	1				
37	97002-06020	BOLT	1				
38	1VP-F172G-00	PANEL 3	1				
39	97707-50016	SCREW, TRUSS HEAD TAPPING	1				
40	90269-06812	RIVET	2				
41	98907-05020	SCREW, BIND	1				
42	90480-12808	GROMMET	1				
43	90387-068L6	COLLAR	1				
44	1VP-F622F-00	DAMPER, LOCATING 1	1				
45	1VP-F172H-00	PANEL 4	1				
46	97707-50016	SCREW, TRUSS HEAD TAPPING	1				
47	90269-06812	RIVET	2				
48	98907-05020	SCREW, BIND	1				
49	90480-12808	GROMMET	1				

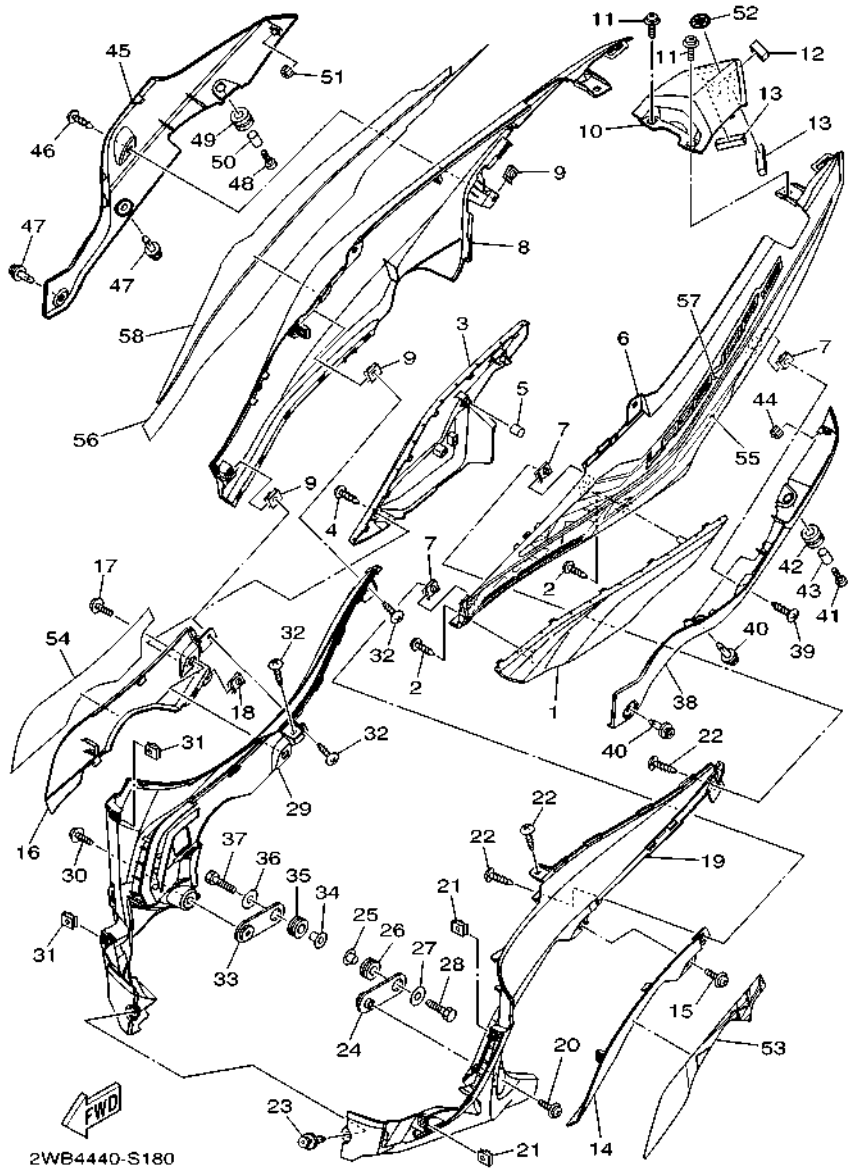

FIG. 18 SIDE COVER

REF. NO.	PART NO.	DESCRIPTION	2WB4	REMARKS
50	90387-068L6	COLLAR	1	
51	1VP-F622F-00	DAMPER, LOCATING 1	1	
52	5PV-F836D-00	TUNING FORK MARK	1	
53	2WB-F173E-30	GRAPHIC 1	1	UR FOR RM7
	2WB-F173E-40	GRAPHIC 1	1	UR FOR MDS
	2WB-F173E-50	GRAPHIC 1	1	UR FOR VPBC5
54	2WB-F173F-30	GRAPHIC 2	1	UR FOR RM7
	2WB-F173F-40	GRAPHIC 2	1	UR FOR MDS
	2WB-F173F-50	GRAPHIC 2	1	UR FOR VPBC5
55	2WB-F174G-30	GRAPHIC 3	1	UR FOR RM7
	2WB-F174G-40	GRAPHIC 3	1	UR FOR MDS
	2WB-F174G-50	GRAPHIC 3	1	UR FOR VPBC5
56	2WB-F174H-30	GRAPHIC 4	1	UR FOR RM7
	2WB-F174H-40	GRAPHIC 4	1	UR FOR MDS
	2WB-F174H-50	GRAPHIC 4	1	UR FOR VPBC5
57	2WB-F174J-30	GRAPHIC 5	1	UR FOR RM7
	2WB-F174J-40	GRAPHIC 5	1	UR FOR MDS
	2WB-F174J-50	GRAPHIC 5	1	UR FOR VPBC5
58	2WB-F174K-30	GRAPHIC 6	1	UR FOR RM7
	2WB-F174K-40	GRAPHIC 6	1	UR FOR MDS
	2WB-F174K-50	GRAPHIC 6	1	UR FOR VPBC5

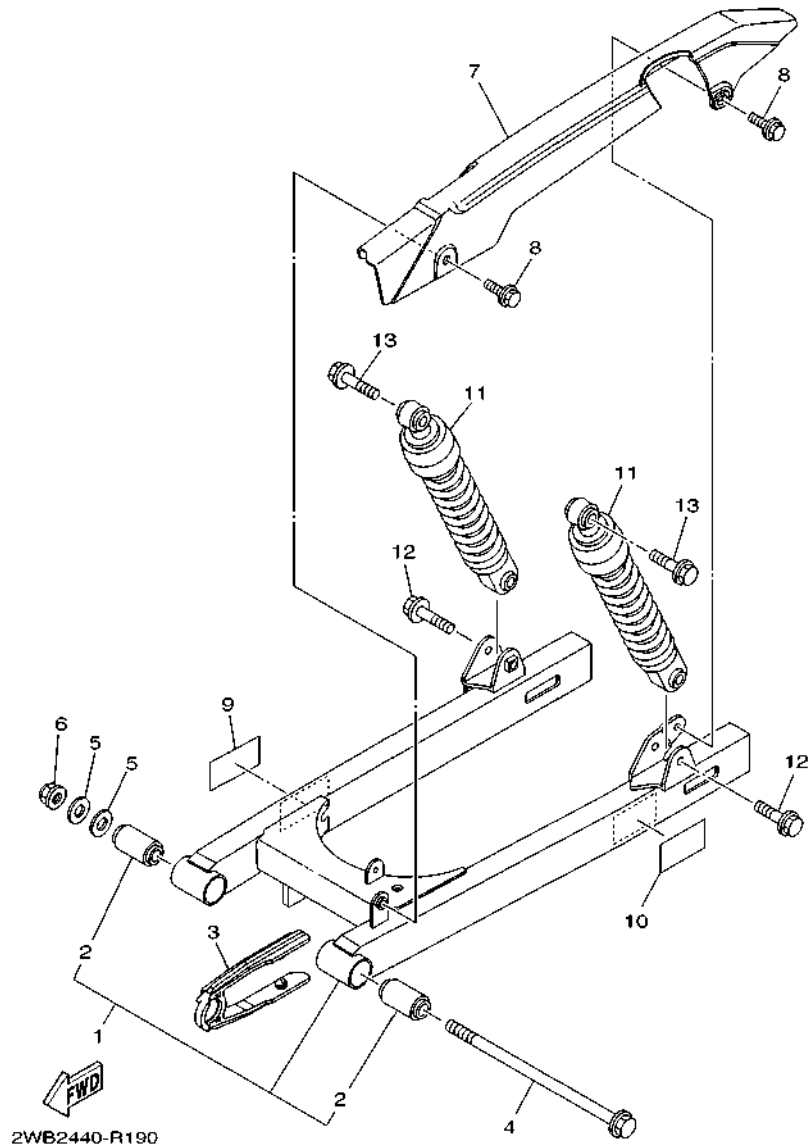

FIG. 19 REAR ARM & SUSPENSION

REF. NO.	PART NO.	DESCRIPTION	2WB4				REMARKS
1	1VP-F2100-00-WN	REAR ARM ASSY	1				CIS
2	4UL-F2123-00	.BUSH 1	2				
3	1VP-F2151-00	SEAL, GUARD	1				
4	5LM-F2141-00	SHAFT, PIVOT	1				
5	90201-12028	WASHER, PLATE	2				
6	95604-12200	NUT, SELF-LOCKING	1				
7	1VP-F2311-00	CASE, CHAIN	1				
8	90119-06117	BOLT, WITH WASHER	2				
9	3XL-F178A-00	LABEL	1				
10	2WB-F1668-00	LABEL, TIRE	1				
11	1VP-F2210-00	SHOCK ABSORBER ASSY, REAR	2				
12	90105-10878	BOLT, FLANGE	2				
13	31D-F2277-00	BOLT	2				

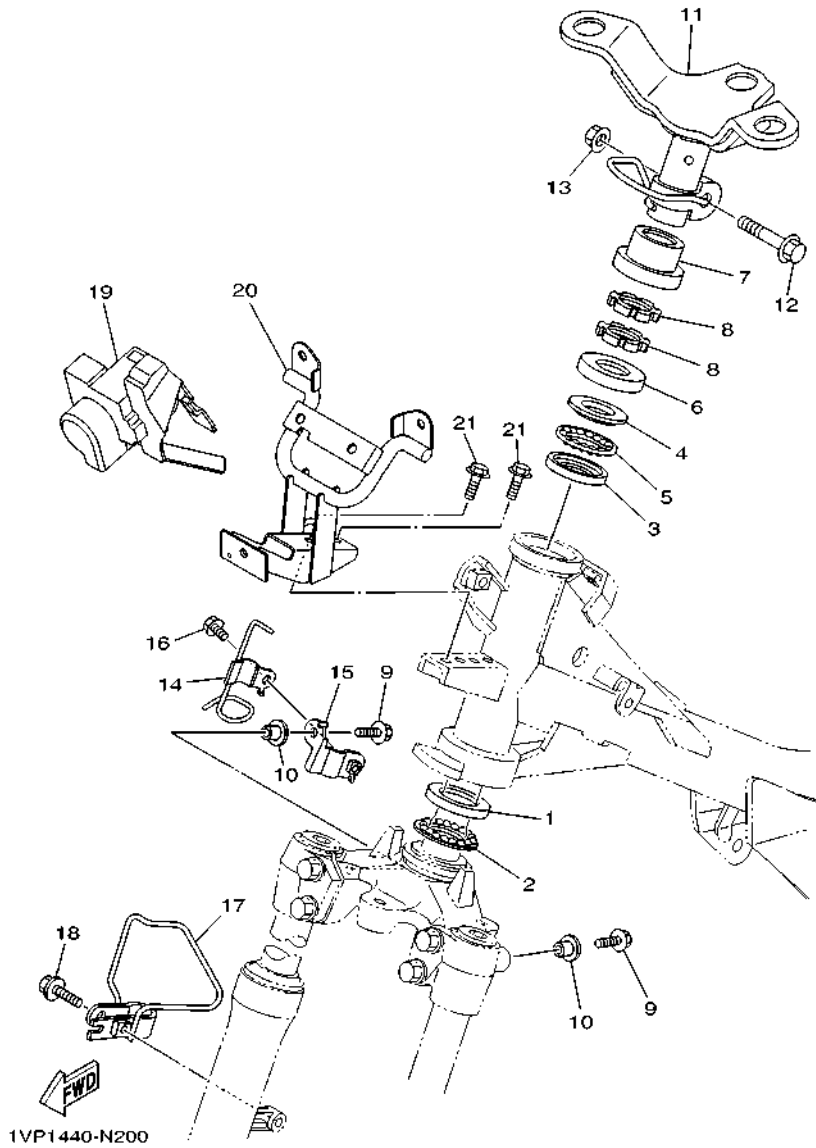

FIG. 20 STEERING

REF. NO.	PART NO.	DESCRIPTION	2WB4				REMARKS
1	156-23412-00	RACE, BALL 2	1				
2	5TL-2341E-00	RETAINER, BALL BEARING (16)	1				
3	22F-23412-01	RACE, BALL 2	1				
4	22F-23411-01	RACE, BALL 1	1				
5	5TL-2341E-10	RETAINER, BALL BEARING (19)	1				
6	3AY-F3416-00	COVER, BALL RACE 2	1				
7	4UV-F3415-00	COVER, BALL RACE 1	1				
8	90179-25033	NUT	2				
9	95022-06016	BOLT, FLANGE	2				
10	90387-06857	COLLAR	2				
11	1VP-F3461-00	BRACKET, HANDLE	1				
12	90105-10864	BOLT, FLANGE	1				
13	90185-10815	NUT, SELF-LOCKING	1				
14	1VP-F5886-00	HOLDER, BRAKE HOSE	1				
15	1VP-F5875-00	HOLDER, BRAKE HOSE 1	1				
16	95022-06010	BOLT, FLANGE	1				
17	5TF-F331E-00	GUIDE, CABLE	1				
18	95022-06025	BOLT, FLANGE	1				
19	1VP-F3472-00	PROTECTOR	1				
20	1VP-F331A-00	STAY	1				
21	95802-06012	BOLT, FLANGE	2				

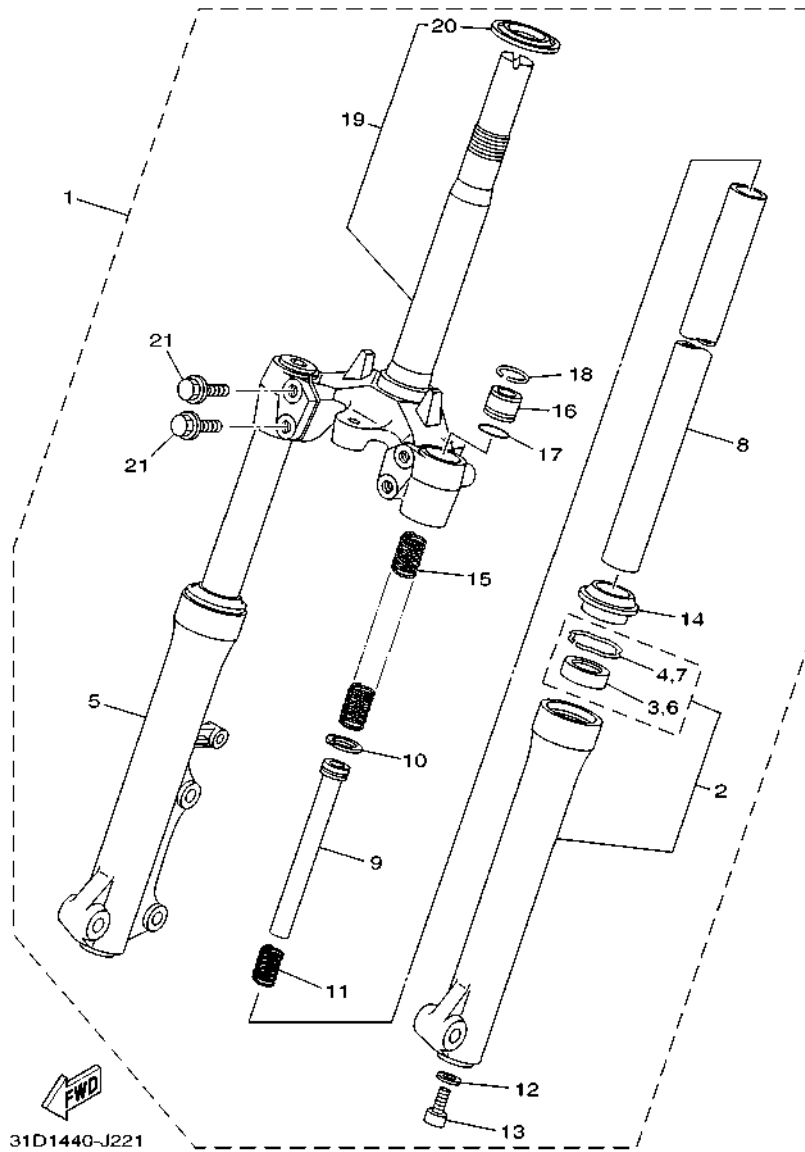
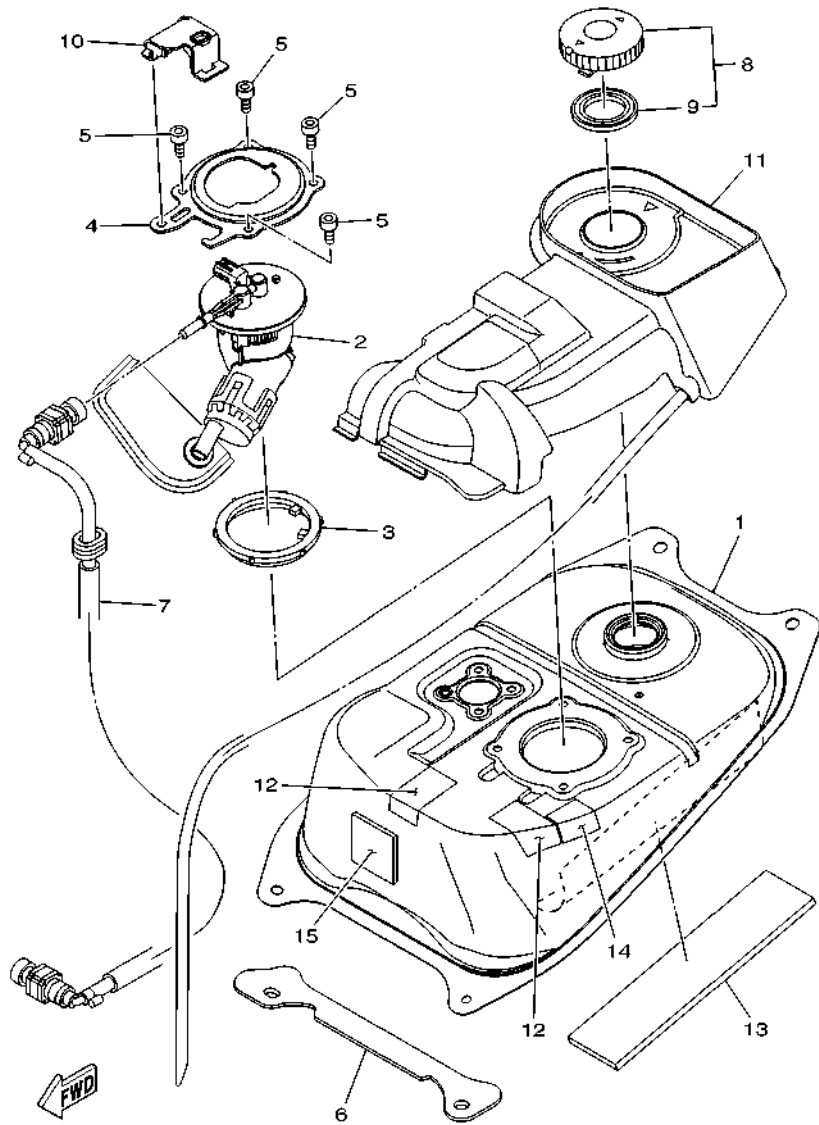

FIG. 21 FRONT FORK

REF. NO.	PART NO.	DESCRIPTION	2WB4				REMARKS
1	31D-F3100-30	FRONT FORK ASSY	1				
2	31D-F3126-00	.TUBE, OUTER (L.H)	1				
3	4UV-F3145-00	.OIL SEAL	1				
4	5P0-F3156-00	.RING, SNAP	1				
5	31D-F3136-10	.TUBE, OUTER 2	1				
6	4UV-F3145-00	.OIL SEAL	1				
7	5P0-F3156-00	.RING, SNAP	1				
8	31B-F3110-00	.INNER TUBE COMP.1	2				
9	31D-F3170-00	.CYLINDER COMP., FRONT FORK	2				
10	2JG-F3157-00	.RING, PISTON	2				
11	31D-F3152-00	.SPRING, SUB	2				
12	509-F3158-L0	.GASKET	2				
13	278-F3181-50	.BOLT, HEXAGON SOCKET HEAD	2				
14	5LL-F3144-00	.SEAL, DUST	2				
15	31B-F3141-00	.SPRING, FRONT FORK	2				
16	5D9-F3111-00	.BOLT, CAP	2				
17	2JG-F3147-00	.O-RING	2				
18	5P0-F3153-00	.RING, SNAP	2				
19	50S-F3340-00	.UNDER BRACKET COMP.	1				
20	156-F3411-00	.RACE, BALL 1	1				
21	2P0-F3346-00	.BOLT 1	4				



2WB2440-R220

FIG. 22 FUEL TANK

REF. NO.	PART NO.	DESCRIPTION	2WB4				REMARKS
1	1VP-F4110-00	FUEL TANK COMP.	1				
2	1DY-E3907-30	FUEL PUMP COMP.	1				
3	54P-F414G-10	SEAL	1				
4	1DY-F4491-00	BRACKET, FUEL PUMP	1				
5	91312-05010	BOLT	4				
6	1VP-F413X-00	PLATE	1				
7	1DY-E3971-01	PIPE, FUEL 1	1				
8	1DY-F4610-00	CAP ASSY	1				
9	4YY-F4612-00	.PACKING, CAP	1				
10	1VP-E3993-00	COVER, CONTROL RACK	1				
11	1VP-F41B1-00	COVER, TANK	1				
12	5D9-F414G-00	SEAL	2				
13	90520-05813	DAMPER, PLATE	1				
14	5D9-F414G-10	SEAL	1				
15	90520-02826	DAMPER, PLATE	1				

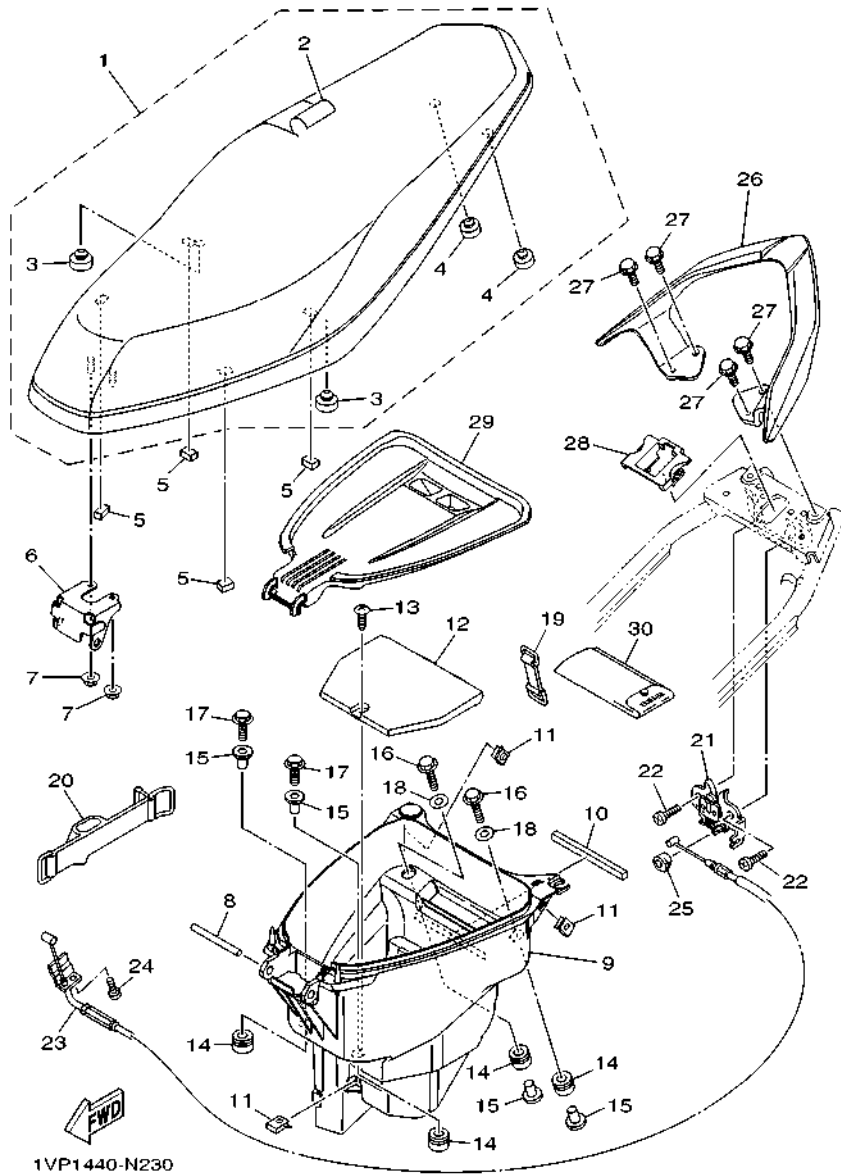

1VP1440-N230

FIG. 23 SEAT

REF. NO.	PART NO.	DESCRIPTION	2WB4	REMARKS
1	1VP-F4730-00	DOUBLE SEAT ASSY	1	
2	1VP-F470F-00	.SEAT COVER COMP.	1	
3	1VP-F4741-10	.PAD, SEAT	2	
4	1VP-F4741-00	.PAD, SEAT	2	
5	5P2-F4724-00	DAMPER, SEAT	4	
6	31D-F4726-00	HINGE, SEAT	1	
7	95702-06500	NUT, FLANGE	2	
8	2WB-F4727-00	PIN, SEAT FITTING	1	
9	1VP-F473R-00	BOX 1	1	
10	10C-F8415-10	DAMPER 1	1	
11	90183-05807	NUT, SPRING	3	
12	1VP-F473T-00	LID 1	1	
13	97702-50016	SCREW, TAPPING	1	
14	90480-14806	GROMMET	4	
15	90387-068D7	COLLAR	4	
16	95022-06035	BOLT, FLANGE	2	
17	95022-06025	BOLT, FLANGE	2	
18	90201-06033	WASHER, PLATE	2	
19	31D-H2131-00	BAND, BATTERY	1	
20	1VP-H2131-00	BAND, BATTERY	1	
21	5P1-F4780-01	SEAT LOCK ASSY	1	
22	98507-06012	SCREW, PAN HEAD	2	
23	1VP-F478E-00	CABLE, SEAT LOCK	1	
24	98502-05010	SCREW, PAN HEAD	1	
25	1S8-F4768-00	STOPPER	1	
26	1VP-F4773-00-P4	HANDLE, SEAT	1	UR FOR RM7
	1VP-F4773-00-P2	HANDLE, SEAT	1	UR SMX FOR MDS

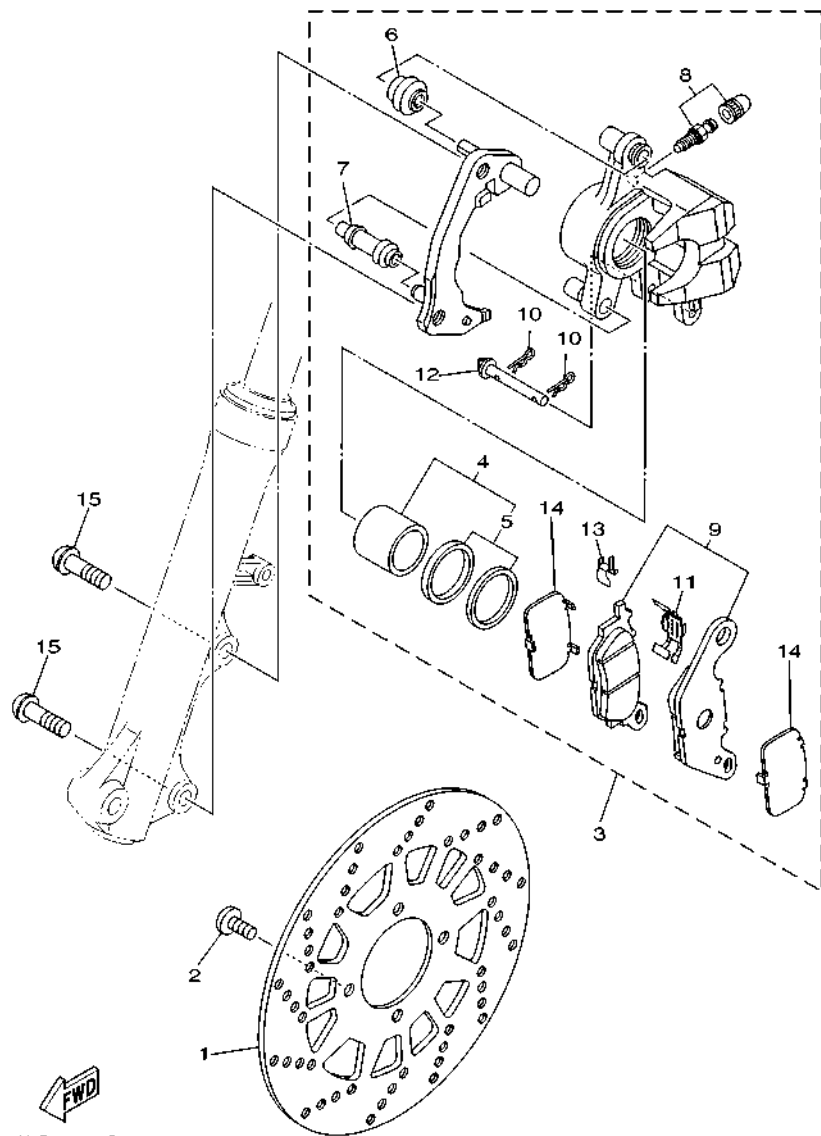

2WB4440-S250

FIG. 25 FRONT BRAKE CALIPER

REF. NO.	PART NO.	DESCRIPTION	2WB4				REMARKS
1	31D-F582U-00	DISK, BRAKE (RIGHT)	1				
2	90111-08853	BOLT,HEX. SOCKET BUTTON	4				
3	31B-F580U-03	CALIPER ASSY (RIGHT)	1				
4	5P0-F5802-00	.PISTON ASSY, CALIPER	1				
5	5YP-F5803-50	..CALIPER SEAL KIT	1				
6	5YP-F5917-00	.BOOT, CALIPER	1				
7	5YP-F5937-00	.BOOT 2	1				
8	4C9-W0048-00	.BLEED SCREW KIT	1				
9	5D9-F5805-01	.BRAKE PAD KIT	1				
10	5YP-F5925-01	.CLIP	2				
11	5P0-F5919-01	.SUPPORT, PAD	1				
12	5YP-F5924-00	.PIN, PAD	1				
13	5YP-F5939-00	.CLIP, PAD	1				
14	5P0-F5827-00	.SHIM, CALIPER	2				
15	90105-10824	BOLT, FLANGE	2				

FIG. 26 REAR WHEEL FOR CAST WHEEL

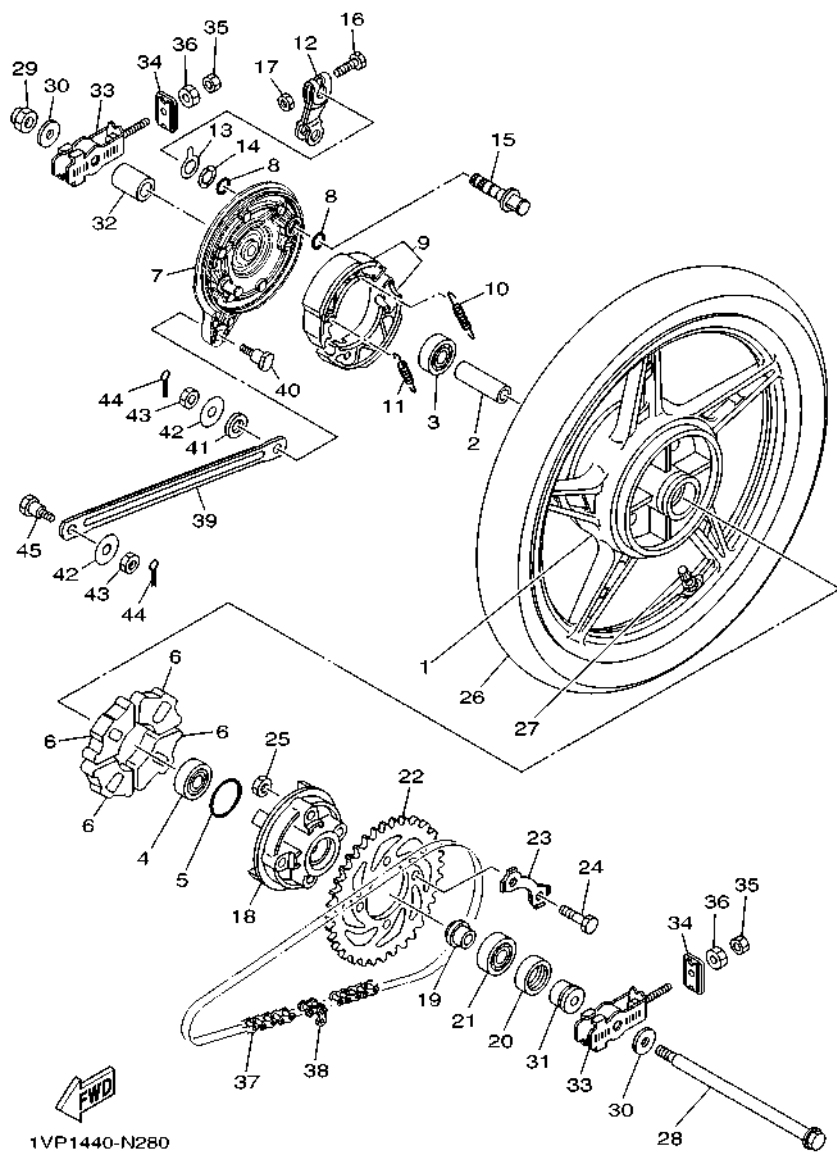

REF. NO.	PART NO.	DESCRIPTION	2WB4	REMARKS
1	1S8-F5338-00-0X	CAST WHEEL, REAR	1	YB/W
2	90560-12145	SPACER	1	
3	93306-301YN	BEARING	1	
4	93306-301YM	BEARING	1	
5	93210-41041	O-RING	1	
6	1VP-F5364-00	DAMPER	4	
7	31D-F5321-00	PLATE, BRAKE SHOE	1	
8	93210-14104	O-RING	2	
9	31D-F530K-00	BRAKE SHOE SET	1	
10	90506-12001	SPRING, TENSION	1	
11	90506-15001	SPRING, TENSION	1	
12	31D-F5355-00	LEVER, CAMSHAFT	1	
13	31D-F533A-00	PLATE, INDICATOR	1	
14	90206-14093	WASHER, WAVE	1	
15	31D-F5351-00	CAMSHAFT	1	
16	97027-06035	BOLT, HEXAGON	1	
17	95307-06600	NUT	1	
18	1VP-F5366-00	CLUTCH, HUB	1	
19	90387-127Y0	COLLAR	1	
20	93106-26815	OIL SEAL	1	
21	93306-004XB	BEARING	1	
22	1VP-F5441-00	SPROCKET, DRIVEN (41T)	1	
23	31D-F5412-00	WASHER	2	
24	90101-08847	BOLT	4	
25	90179-08639	NUT	4	
26	94108-17867	TIRE (80/90-17 M/C 50P V420R)	1	VEE RUBBER
27	93900-00817	VALVE, RIM (TR412)	1	

FIG. 26 REAR WHEEL FOR CAST WHEEL

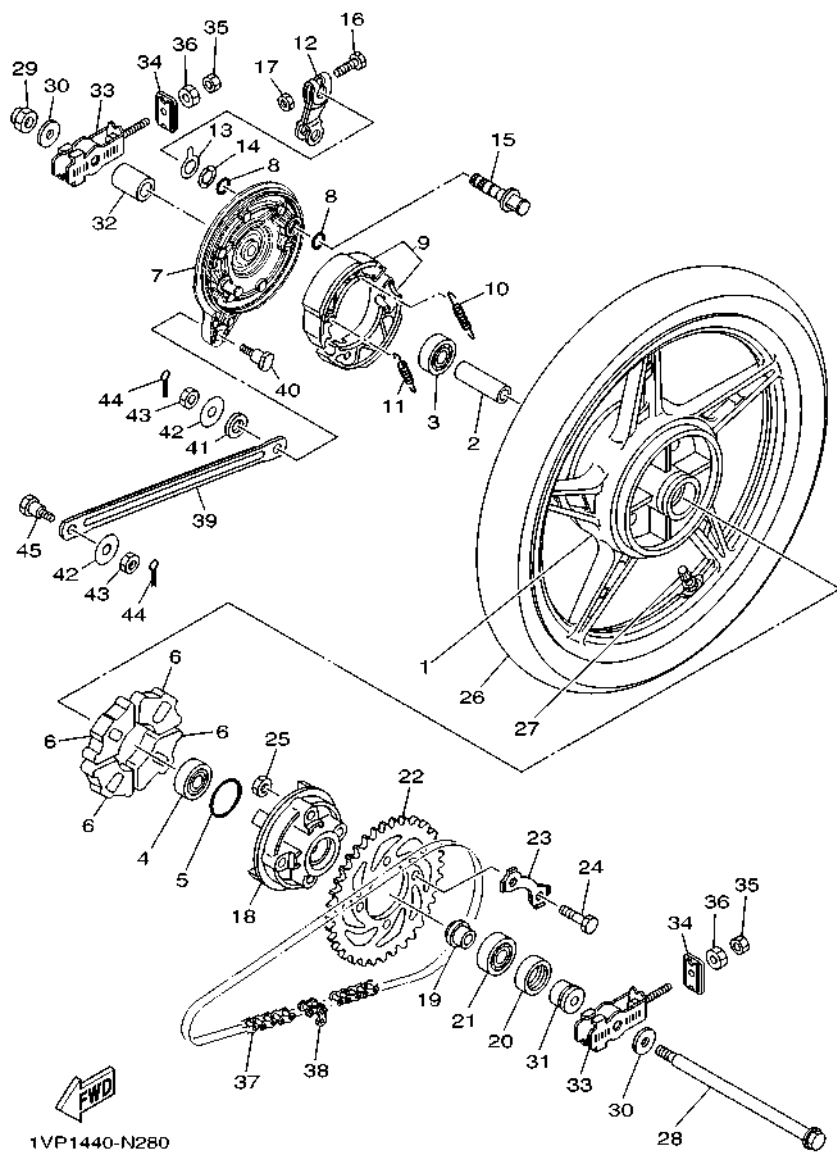

1VP1440-N280

REF. NO.	PART NO.	DESCRIPTION	2WB4				REMARKS
28	3XA-F5381-01	AXLE, WHEEL	1				
29	90185-12046	NUT, SELF-LOCKING	1				
30	90201-12833	WASHER, PLATE	2				
31	5LL-F5383-00	COLLAR, WHEEL	1				
32	90387-12849	COLLAR	1				
33	5TF-F5389-00	PULLER, CHAIN 2	2				
34	5TF-F539F-00	PLATE 1	2				
35	95307-06600	NUT	2				
36	90170-06184	NUT	2				
37	94568-E1107	CHAIN (RK-M 428SB X 107L)	1				
38	94668-84001	JOINT, CHAIN (RK-M 428M)	1				
39	31D-F5371-00	BAR, TENSION	1				
40	90109-08828	BOLT	1				
41	90202-10800	WASHER, PLATE	1				
42	90201-081J7	WASHER, PLATE	2				
43	95304-08700	NUT	2				
44	91401-20012	PIN, COTTER	2				
45	31D-F5373-00	BOLT, TENSION BAR	1				

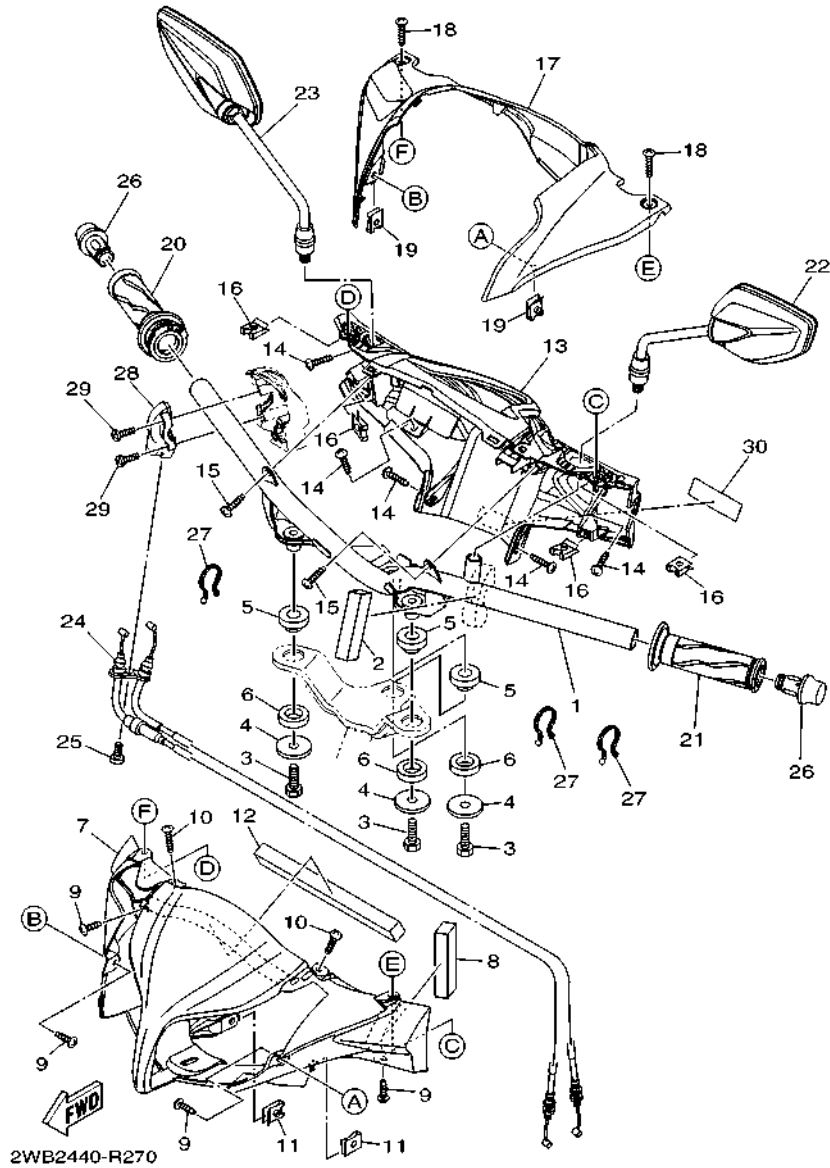
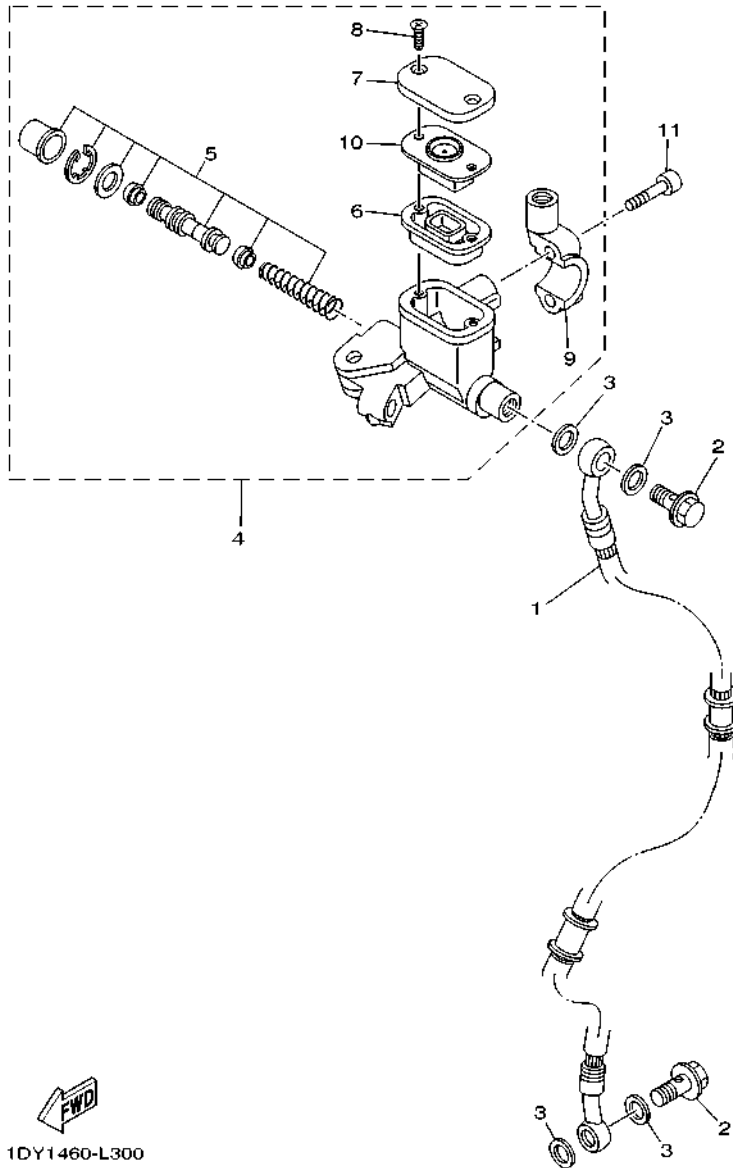

FIG. 27 STEERING HANDLE & CABLE

REF. NO.	PART NO.	DESCRIPTION	2WB4	REMARKS
1	1VP-F6210-00	HANDLE	1	
2	90520-25802	DAMPER, PLATE	1	
3	97002-08016	BOLT	3	
4	90201-088C4	WASHER, PLATE	3	
5	5D9-F8217-00	DAMPER 1	3	
6	5D9-F8227-00	DAMPER 2	3	
7	1VP-F6143-00	COVER, HANDLE UPPER 1	1	
8	90520-25802	DAMPER, PLATE	1	
9	97707-50012	SCREW, TRUSS HEAD TAPPING	4	
10	97707-50016	SCREW, TRUSS HEAD TAPPING	2	
11	90183-05807	NUT, SPRING	2	
12	90520-20811	DAMPER, PLATE	1	
13	1VP-F6145-00	COVER, HANDLE UPPER 2	1	
14	97707-50012	SCREW, TRUSS HEAD TAPPING	5	
15	97707-50016	SCREW, TRUSS HEAD TAPPING	2	
16	90183-05807	NUT, SPRING	4	
17	1VP-F6216-00-P4	CAP, HANDLEBAR COVER	1	UR FOR RM7
	1VP-F6216-00-7M	CAP, HANDLEBAR COVER	1	UR FOR MDS
	1VP-F6216-00-P7	CAP, HANDLEBAR COVER	1	UR FOR VPBC5
18	97707-50016	SCREW, TRUSS HEAD TAPPING	2	
19	90183-05807	NUT, SPRING	2	
20	1VP-F6240-00	GRIP ASSY	1	
21	1VP-F6241-00	GRIP	1	
22	2WB-F6280-00	REAR VIEW MIRROR ASSY (LEFT)	1	
23	2WB-F6290-00	REAR VIEW MIRROR ASSY (RIGHT)	1	
24	1VP-F6301-00	THROTTLE CABLE ASSY	1	
25	92012-05016	BOLT, BUTTON HEAD	1	

FIG. 28 FRONT MASTER CYLINDER



1DY1460-L300

REF. NO.	PART NO.	DESCRIPTION	2WB4				REMARKS
1	1DY-F5872-00	HOSE, BRAKE 1	1				
2	90401-10159	BOLT, UNION	2				
3	90201-10118	WASHER, PLATE	4				
4	5P0-F583T-13	MASTER CYLINDER ASSY (BLACK)	1				
5	5P0-W0041-00	.CYLINDER KIT, MASTER	1				
6	5P0-F5854-00	.DIAPHRAGM, RESERVOIR	1				
7	5P0-F5852-10	.CAP, RESERVOIR (BLACK)	1				
8	36Y-2589H-00	.SCREW	2				
9	5TL-F5867-11	.BRACKET, MASTER CYLINDER (BLACK)	1				
10	5P0-F5855-00	.BUSH, DIAPHRAGM	1				
11	91312-06025	BOLT, HEXAGON SOCKET HEAD	2				

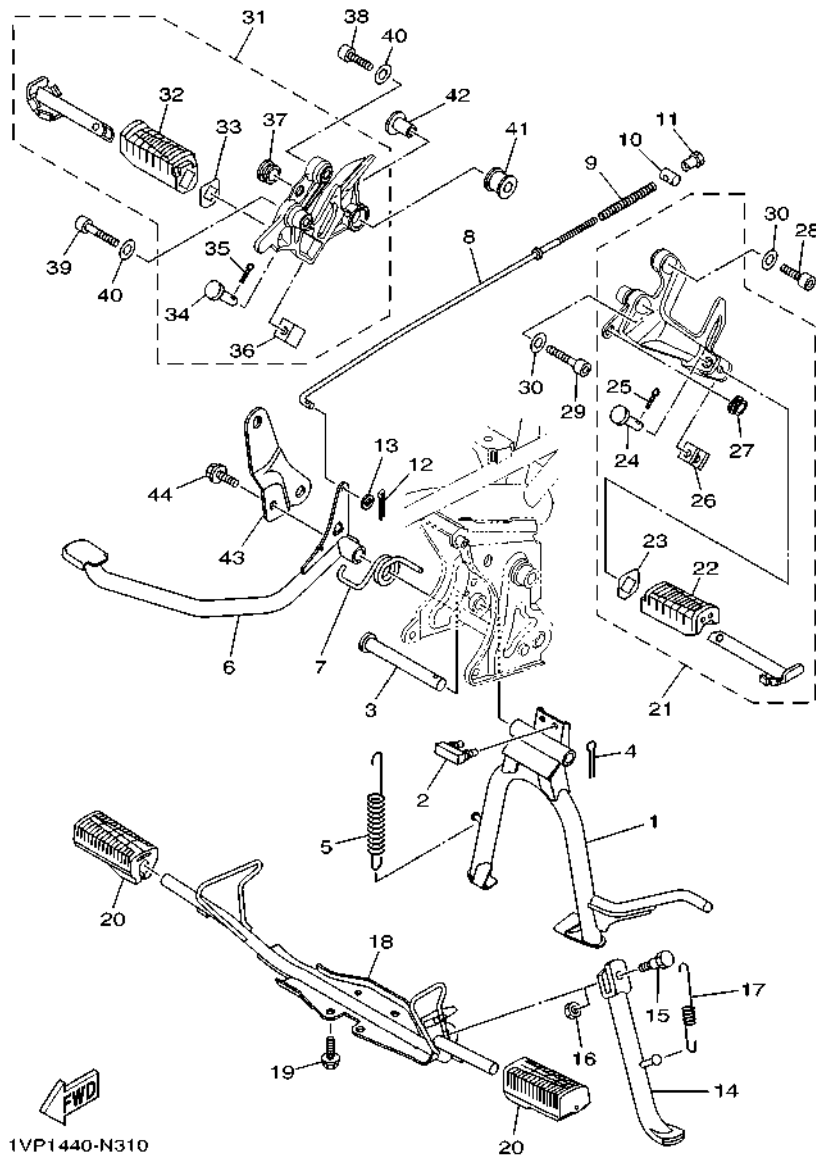

FIG. 29 STAND & FOOTREST

REF. NO.	PART NO.	DESCRIPTION	2WB4	REMARKS
1	1VP-F7111-00	STAND, MAIN	1	
2	31D-F7114-00	STOPPER, MAIN STAND	1	
3	31D-F7112-00	SHAFT, MAIN STAND	1	
4	91401-30030	PIN, COTTER	1	
5	90506-35806	SPRING, TENSION	1	
6	31D-F7211-00	PEDAL, BRAKE	1	
7	90508-40810	SPRING, TORSION	1	
8	5D9-F7231-00	ROD, BRAKE	1	
9	90501-10245	SPRING, COMPRESSION	1	
10	90249-12008	PIN	1	
11	90179-06835	NUT	1	
12	91401-20012	PIN, COTTER	1	
13	92902-06600	WASHER, PLATE	1	
14	1VP-F7311-00	STAND, SIDE	1	
15	90109-08850	BOLT	1	
16	95302-08700	NUT, HEXAGON	1	
17	90506-23810	SPRING, TENSION	1	
18	1VP-F7411-00	FOOTREST 1	1	
19	95822-08016	BOLT, FLANGE	4	
20	5LL-F7413-00	COVER, FOOTREST	2	
21	1VP-F7430-00	REAR FOOTREST ASSY 1	1	
22	5TF-F7433-00	.COVER, REAR FOOTREST	1	
23	5BU-F7445-00	.PLATE 1	1	
24	90240-08145	.PIN, CLEVIS	1	
25	91401-25015	.PIN, COTTER	1	
26	5TF-F7314-00	.STOPPER	1	
27	90480-01559	.GROMMET	1	

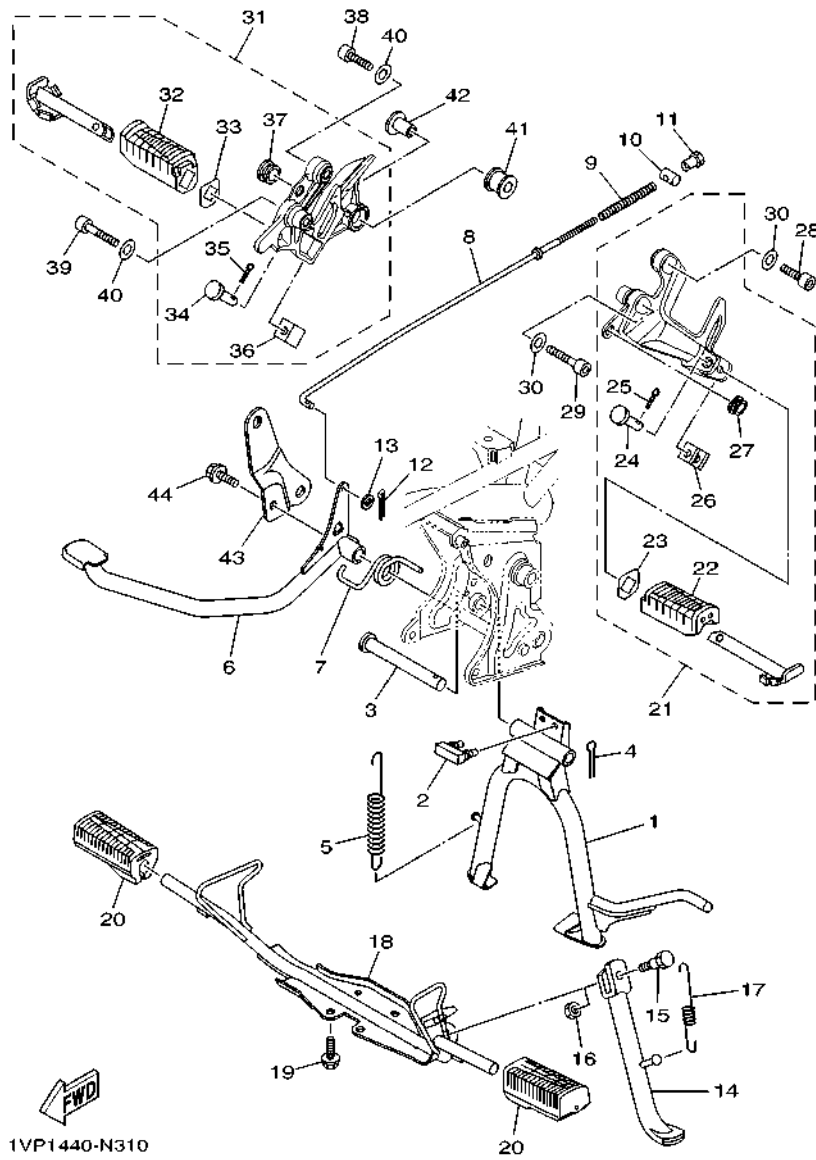
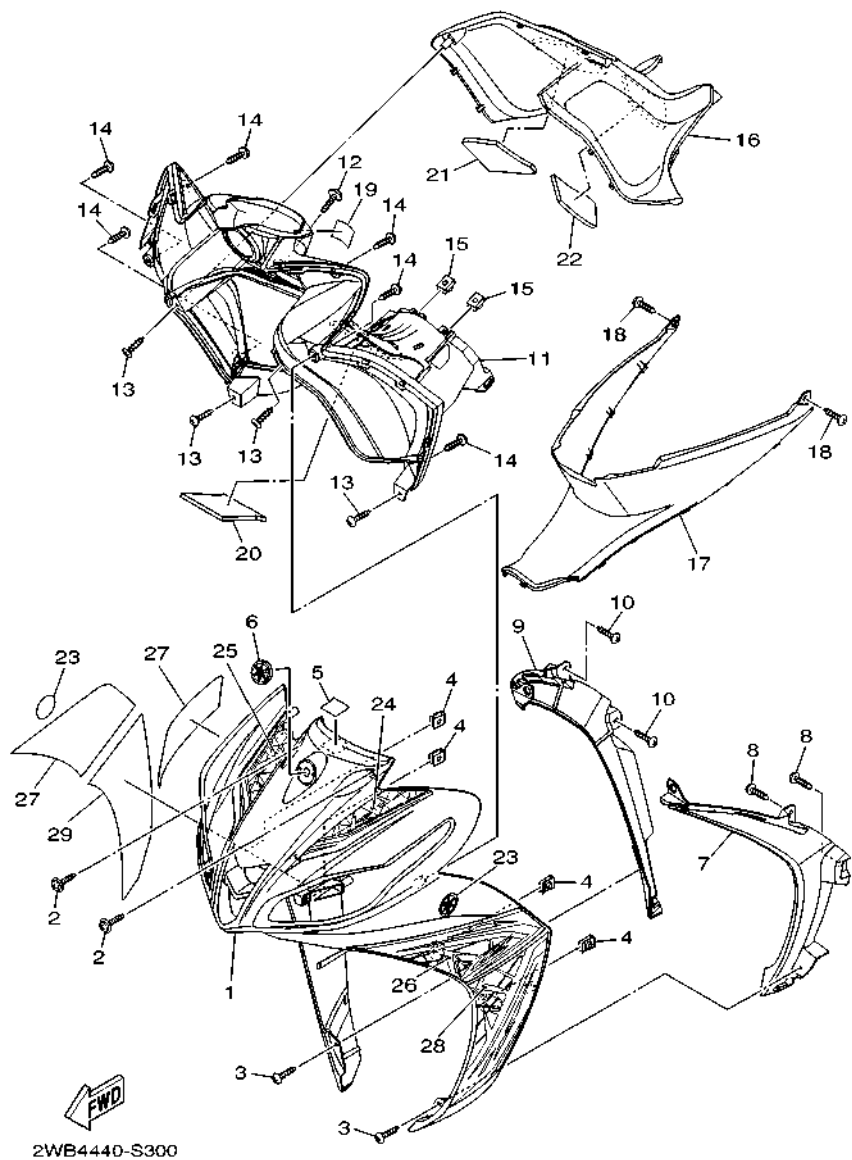

FIG. 29 STAND & FOOTREST

REF. NO.	PART NO.	DESCRIPTION	2WB4				REMARKS
28	91312-08020	BOLT	1				
29	91312-08035	BOLT	1				
30	90201-08057	WASHER, PLATE	2				
31	1VP-F7440-00	REAR FOOTREST ASSY 2	1				
32	5TF-F7444-00	.COVER, REAR FOOTREST	1				
33	5BU-F7445-00	.PLATE 1	1				
34	90240-08145	.PIN, CLEVIS	1				
35	91401-25015	.PIN, COTTER	1				
36	5TF-F7314-00	.STOPPER	1				
37	90480-13398	.GROMMET	1				
38	91312-08020	BOLT	1				
39	91312-08035	BOLT	1				
40	90201-08057	WASHER, PLATE	2				
41	29B-E4747-00	DAMPER, MUFFLER	1				
42	90387-08830	COLLAR	1				
43	1VP-F194J-00	STAY, MUFFLER	1				
44	95822-08016	BOLT, FLANGE	1				

FIG. 30 LEG SHIELD



REF. NO.	PART NO.	DESCRIPTION	2WB4	REMARKS
1	1VP-F8311-00-P4	LEG SHIELD 1	1	UR FOR RM7
	1VP-F8311-00-7M	LEG SHIELD 1	1	UR FOR MDS
	1VP-F8311-00-P6	LEG SHIELD 1	1	UR S3 FOR VPBC5
2	90159-06067	SCREW, WITH WASHER	2	
3	97707-50016	SCREW, TRUSS HEAD TAPPING	2	
4	90183-05807	NUT, SPRING	4	
5	5D9-F414G-10	SEAL	1	
6	31B-F313B-00	EMBLEM, 1	1	
7	1VP-F836K-00	PANEL, INNER 1	1	
8	97702-50016	SCREW, TAPPING	2	
9	1VP-F836L-00	PANEL, INNER 2	1	
10	97702-50016	SCREW, TAPPING	2	
11	1VP-F8312-00	LEG SHIELD 2	1	
12	90159-06067	SCREW, WITH WASHER	1	
13	97702-50016	SCREW, TAPPING	4	
14	97707-50016	SCREW, TRUSS HEAD TAPPING	6	
15	90183-05807	NUT, SPRING	2	
16	2WB-F8349-00	CAP	1	
17	1VP-F842N-00	COVER 2	1	
18	97702-50016	SCREW, TAPPING	2	
19	31D-F1568-30	LABEL, WARNING	1	
20	2WB-F8371-00	DAMPER	1	
21	2WB-F836T-00	DAMPER, LOCATING 1	1	
22	2WB-F836U-00	DAMPER, LOCATING 2	1	
23	1S8-F175C-00	TUNING FORK MARK	2	
24	2WB-F8391-30	GRAPHIC 1	1	UR FOR RM7
	2WB-F8391-40	GRAPHIC 1	1	UR FOR MDS

FIG. 30 LEG SHIELD

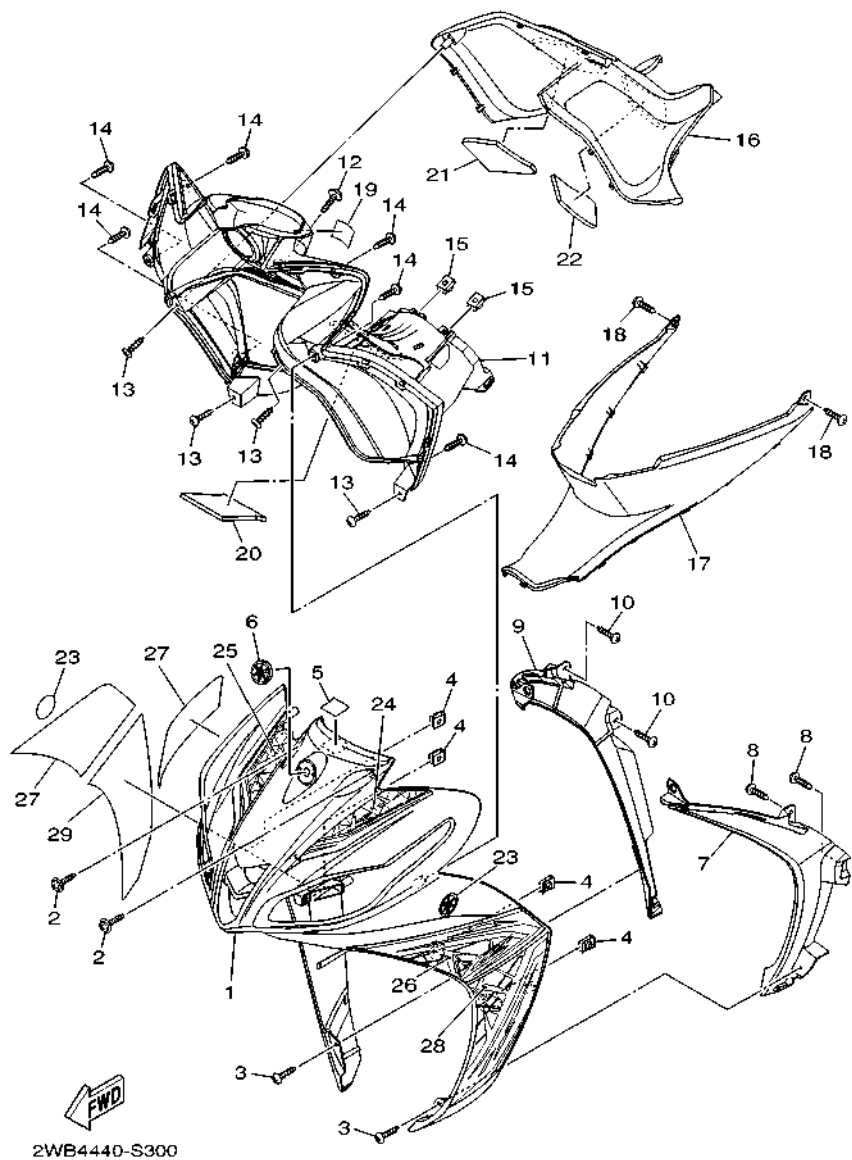

REF. NO.	PART NO.	DESCRIPTION	2WB4			REMARKS
24	2WB-F8391-50	GRAPHIC 1	1			UR FOR VPBC5
25	2WB-F8392-30	GRAPHIC 2	1			UR FOR RM7
	2WB-F8392-40	GRAPHIC 2	1			UR FOR MDS
	2WB-F8392-50	GRAPHIC 2	1			UR FOR VPBC5
26	2WB-F8398-30	GRAPHIC 5	1			UR FOR RM7
	2WB-F8398-40	GRAPHIC 5	1			UR FOR MDS
	2WB-F8398-50	GRAPHIC 5	1			UR FOR VPBC5
27	2WB-F8399-30	GRAPHIC 6	1			UR FOR RM7
	2WB-F8399-40	GRAPHIC 6	1			UR FOR MDS
	2WB-F8399-50	GRAPHIC 6	1			UR FOR VPBC5
28	2WB-F839A-00	GRAPHIC 7	1			UR FOR RM7
	2WB-F839A-10	GRAPHIC 7	1			UR FOR MDS
	2WB-F839A-20	GRAPHIC 7	1			UR FOR VPBC5
29	2WB-F839E-00	GRAPHIC 8	1			UR FOR RM7
	2WB-F839E-10	GRAPHIC 8	1			UR FOR MDS
	2WB-F839E-20	GRAPHIC 8	1			UR FOR VPBC5

FIG. 32 STARTING MOTOR

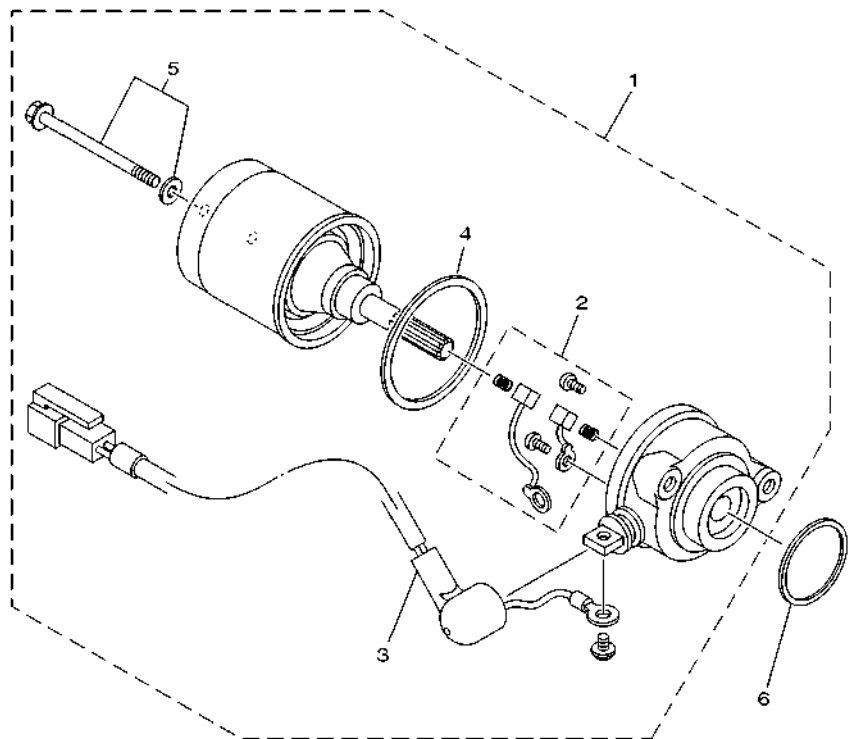

REF. NO.	PART NO.	DESCRIPTION	2WB4	REMARKS
1	1DY-H1800-00	STARTING MOTOR ASSY	1	
2	5TP-H1801-00	.BRUSH SET	1	
3	1DY-H183G-00	.CORD COMP.	1	
4	5D9-H1861-00	.GASKET	1	
5	5D9-H1828-00	.SCREW SET	2	
6	93210-29803	O-RING	1	

 1DY1460-L340

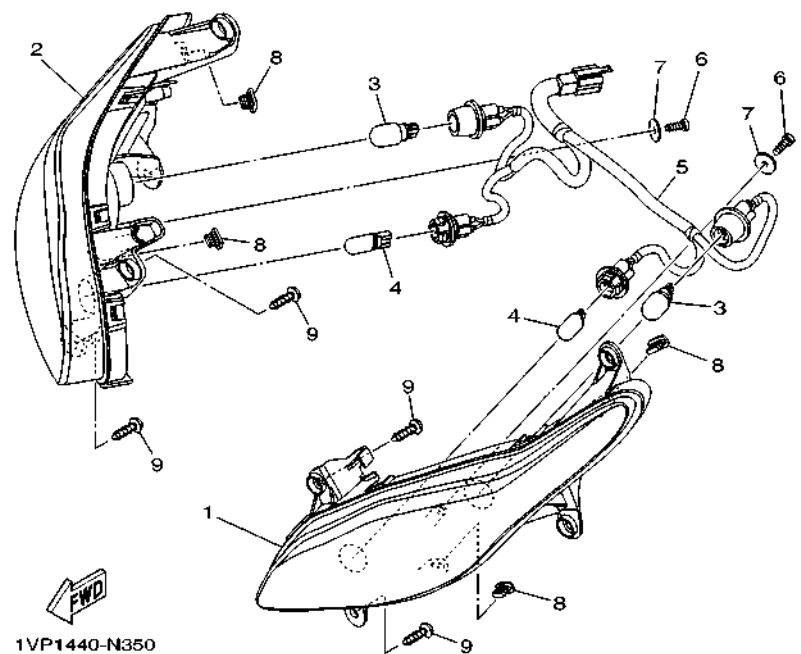
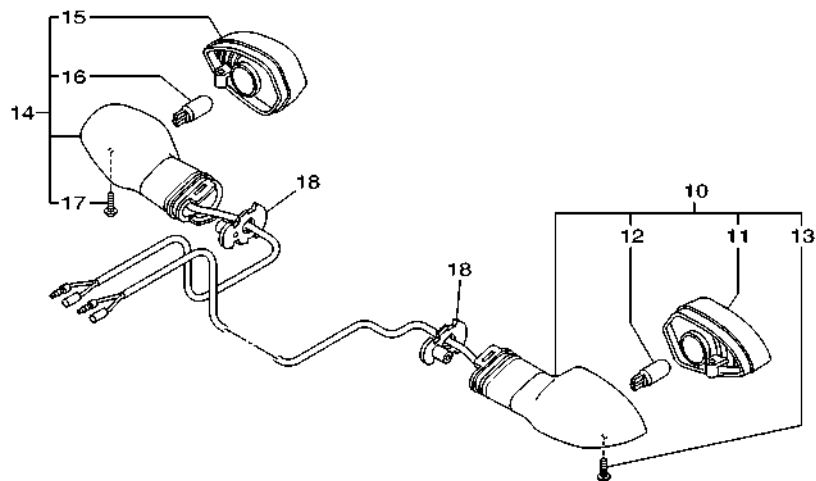

FIG. 33 FLASHER LIGHT

REF. NO.	PART NO.	DESCRIPTION	2WB4	REMARKS
1	1VP-H3310-00	FRONT FLASHER LIGHT ASSY 1	1	
2	1VP-H3320-00	FRONT FLASHER LIGHT ASSY 2	1	
3	1VP-H4147-00	BULB, FLASHER (12V-16W)	2	
4	1VP-H3311-00	BULB (12V-10W)	2	
5	1VP-H4140-00	SOCKET CORD ASSY	1	
6	97702-40512	SCREW, TAPPING	2	
7	2BR-H1554-00	WASHER	2	
8	1VP-H4762-00	GROMMET	4	
9	97702-50016	SCREW, TAPPING	4	
10	1VP-H3330-00	REAR FLASHER LIGHT ASSY 1	1	
11	1VP-H333A-00	.LENS COMP 1	1	
12	1VP-H3311-00	.BULB (12V-10W)	1	
13	1VP-H3333-00	.SCREW, LENS FITTING	1	
14	1VP-H3340-00	REAR FLASHER LIGHT ASSY 2	1	
15	1VP-H334A-00	.LENS COMP 2	1	
16	1VP-H3311-00	.BULB (12V-10W)	1	
17	1VP-H3333-00	.SCREW, LENS FITTING	1	
18	1VP-H3318-00	STAY, FLASHER 1	2	

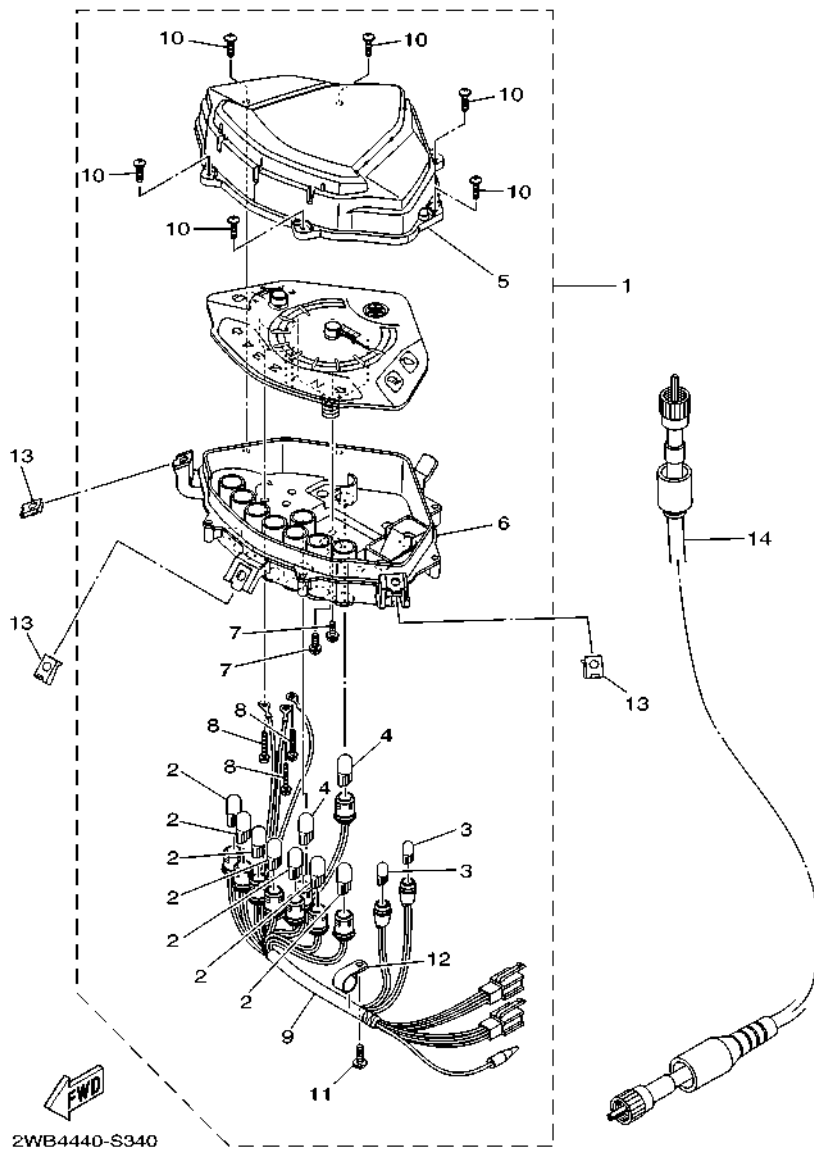
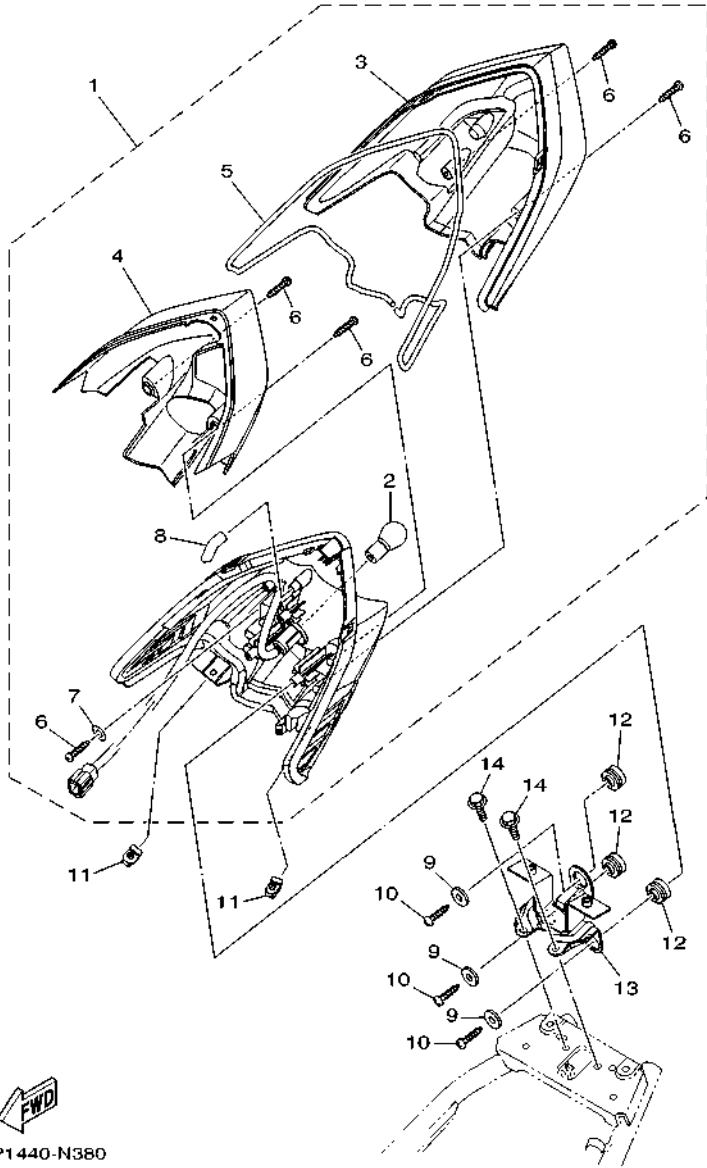

FIG. 34 METER

REF. NO.	PART NO.	DESCRIPTION	2WB4				REMARKS
1	2WB-H3510-00	SPEEDOMETER ASSY	1				
2	5LW-H3518-00	.BULB, METER (T10 12V-1.7W)	7				
3	5BU-H3517-00	.BULB (T6.5 12V-1.7W)	2				
4	1VP-H3517-00	.BULB, METER (T10 12V-3.4W)	2				
5	1VP-H3511-00	.LENS, SPEEDOMETER	1				
6	1VP-H353F-00	.CASE, METER LOWER	1				
7	1VP-H3358-00	.SCREW, SPECIAL	2				
8	1VP-H3645-00	.SCREW	3				
9	1VP-H3509-00	.SOCKET CORD ASSY	1				
10	97702-30012	.SCREW, TAPPING	6				
11	97702-40012	.SCREW, TAPPING	1				
12	1VP-H357E-00	.CLAMP	1				
13	90183-05807	NUT, SPRING	3				
14	1VP-H3550-00	SPEEDOMETER CABLE ASSY	1				



1VP1440-N380

FIG. 36 TAILLIGHT

REF. NO.	PART NO.	DESCRIPTION	2WB4				REMARKS
1	1VP-H4710-00	TAILLIGHT UNIT ASSY	1				
2	1VP-H4714-00	.BULB, TAILLIGHT (12V-21/5W)	1				
3	1VP-H4743-00	.LENS, LICENCE LIGHT	1				
4	1VP-H4721-00	.LENS, TAILLIGHT	1				
5	1VP-H4723-00	.GASKET, TAIL LENS	1				
6	97707-40616	.SCREW, TAPPING	5				
7	2BR-H1554-00	.WASHER	1				
8	55C-H3365-00	.CAP	1				
9	90201-06033	WASHER, PLATE	3				
10	97702-50014	SCREW, TAPPING	3				
11	90183-05815	NUT, SPRING	2				
12	90480-18809	GROMMET	3				
13	1VP-H4702-00	BRACKET, TAILLIGHT	1				
14	97522-06514	BOLT, WITH WASHER	2				

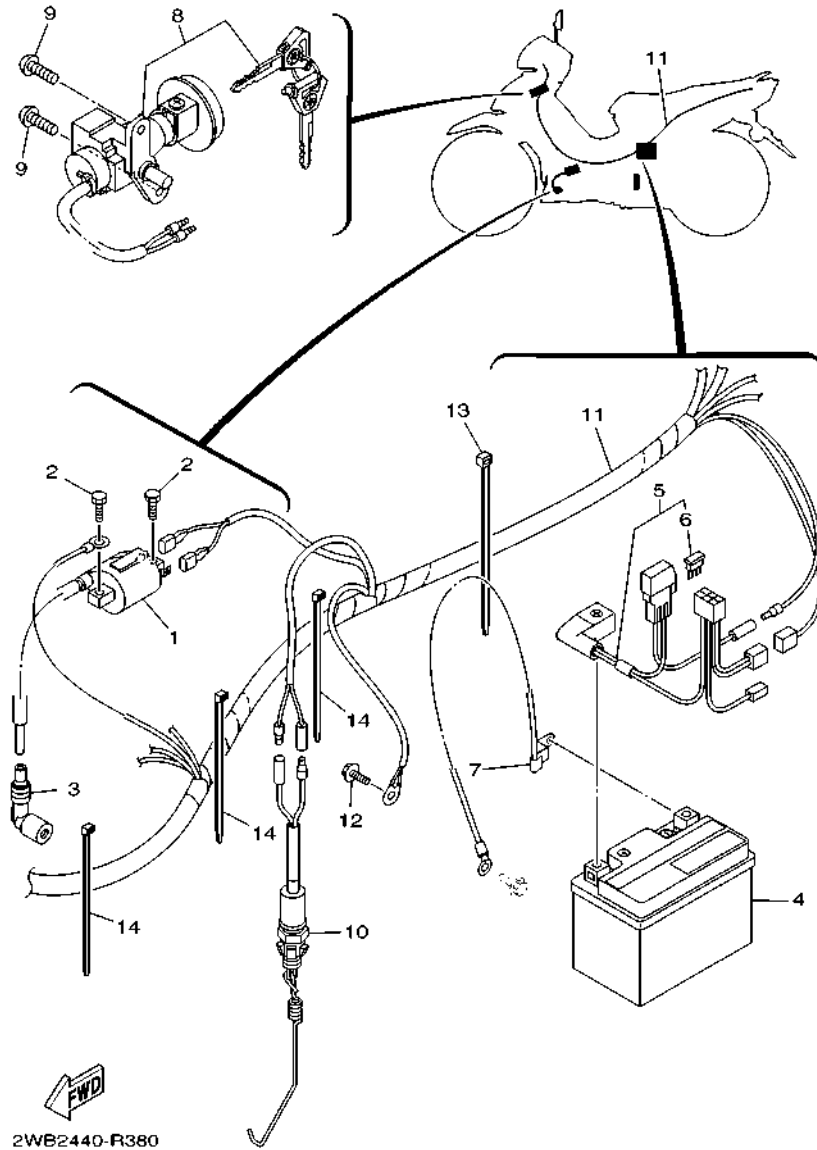

FIG. 38 ELECTRICAL 1

REF. NO.	PART NO.	DESCRIPTION	2WB4				REMARKS
1	1DY-H2310-00	IGNITION COIL ASSY	1				
2	95023-06016	BOLT	2				
3	1LB-H2370-00	PLUG CAP ASSY	1				
4	10C-H2100-02	BATTERY ASSY (YUASA YTZ5S)	1				
5	2WB-H2115-00	WIRE, PLUS LEAD	1				
6	1VP-H2151-00	.FUSE (15A)	1				
7	1VP-H2116-10	WIRE, MINUS LEAD	1				
8	1VP-H252E-00	MAIN SWITCH COMP.	1				
9	90149-06309	SCREW	2				
10	1FD-H2530-00	STOP SWITCH ASSY	1				
11	2WB-H2590-00	WIRE HARNESS ASSY	1				
12	95022-06014	BOLT, FLANGE	1				
13	90465-13152	CLAMP	1				
14	90464-36800	CLAMP	3				

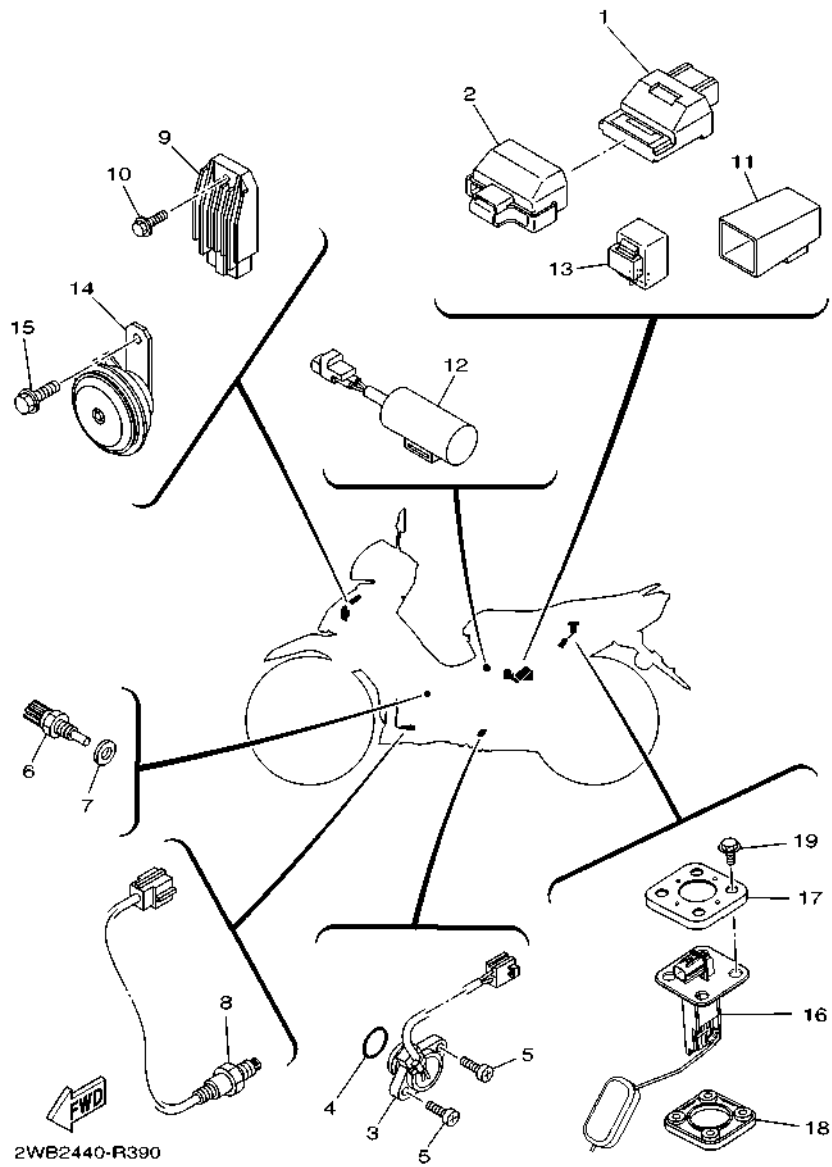

FIG. 39 ELECTRICAL 2

REF. NO.	PART NO.	DESCRIPTION	2WB4				REMARKS
1	2WB-H591A-00	ENGINE CONTROL UNIT ASSY	1				
2	2SU-H5546-00	BAND	1				
3	1DY-H2540-00	NEUTRAL SWITCH ASSY	1				
4	93210-21800	O-RING	1				
5	98502-05016	SCREW, PAN HEAD	2				
6	52B-H3591-00	THERMO UNIT	1				
7	90430-10804	GASKET	1				
8	2BM-H592A-00	SENSOR, OXYGEN	1				
9	1FC-H1960-00	RECTIFIER & REGULATOR ASSY	1				
10	95022-06014	BOLT, FLANGE	1				
11	5TP-H1940-00	STARTER RELAY ASSY	1				
12	1PB-H1965-00	CONDENSER, SMOOTHING	1				
13	1VP-83350-00	FLASHER RELAY ASSY	1				
14	1VP-H3371-00	HORN	1				
15	95802-08012	BOLT, FLANGE	1				
16	1DY-H5752-00	SENDER UNIT ASSY, FUEL METER	1				
17	5BU-H5757-00	RETAINER	1				
18	5BU-H5753-01	GASKET, SENDER UNIT	1				
19	90119-05022	BOLT, WITH WASHER	4				

NUMERICAL INDEX

PART NO.	REF. NO.	PART NO.	REF. NO.	PART NO.	REF. NO.	PART NO.	REF. NO.	PART NO.	REF. NO.	PART NO.	REF. NO.
4BD-14766-00	7 - 5	54P-E2241-00	4 - 9	5D9-E5461-10	9 - 14	5H3-E8113-00	15 - 24	2WB-F173F-40	18 - 54	50S-F3340-00	21 - 19
5TF-14766-00	7 - 7	44D-E2662-00	3 - 11	5TN-E5512-00	11 - 1	1DY-E8120-01	14 - 7	2WB-F173F-50	18 - 54	2P0-F3346-00	21 - 21
22F-23411-01	20 - 4	1DY-E3300-00	5 - 1	5TN-E5512-00	11 - 3	1DY-E8140-00	15 - 7	1VP-F1741-00-7M	18 - 8	156-F3411-00	21 - 20
156-23412-00	20 - 1	31D-E3324-00	5 - 7	1DY-E5580-00	11 - 6	1DY-E8172-10	15 - 3	1VP-F1741-00-P0	18 - 8	4UV-F3415-00	20 - 7
22F-23412-01	20 - 3	4LS-E3411-00	5 - 5	1DY-E5580-10	11 - 6	5LM-E8173-00	15 - 15	2WB-F174G-30	18 - 55	3AY-F3416-00	20 - 6
5TL-2341E-00	20 - 2	38B-E3440-00	5 - 6	1VP-E5620-00	10 - 11	1DY-E8179-10	15 - 2	1VP-F174G-40	18 - 55	1VP-F3461-00	20 - 11
5TL-2341E-10	20 - 5	1VP-E3447-00	5 - 8	5D9-E5641-00	10 - 2	1VP-E817A-00	15 - 16	2WB-F174G-50	18 - 55	1DY-F3469-00	35 - 5
36Y-2589H-00	28 - 8	54P-E3575-00	6 - 13	4WH-E5644-00	10 - 5	5D9-E8181-00	15 - 4	2WB-F174H-30	18 - 56	1VP-F3472-00	20 - 19
1VP-83350-00	39 - 13	2SU-E3585-00	6 - 1	5D9-E5645-10	10 - 8	2SU-E8185-00	14 - 2	2WB-F174H-40	18 - 56	1VP-F4110-00	22 - 1
1VP-E1102-00	1 - 1	2SU-E3750-00	6 - 4	5D9-E5661-20	10 - 1	5D9-E8186-00	15 - 17	2WB-F174H-50	18 - 56	1VP-F413X-00	22 - 6
54P-E111F-00	4 - 4	2SU-E3761-00	6 - 7	5D9-E5664-20	10 - 9	5D9-E8337-10	15 - 8	2WB-F174J-30	18 - 57	5D9-F414G-00	22 - 12
54S-E1133-10	1 - 2	2SU-E3770-00	6 - 6	5D9-E5671-10	10 - 4	5D9-E8511-00	14 - 11	2WB-F174J-40	18 - 57	54P-F414G-10	22 - 3
1DY-E1166-00	8 - 3	1DY-E3907-30	22 - 2	1FD-E6135-00	12 - 23	5D9-E8512-00	14 - 12	2WB-F174J-50	18 - 57	5D9-F414G-10	22 - 14
1FC-E1173-00	1 - 12	2SU-E3938-00	6 - 10	1VP-E6150-00	12 - 13	5D9-E8531-00	14 - 9	2WB-F174K-30	18 - 58	30 - 5	
54P-E1181-00	1 - 18	1DY-E3971-01	22 - 7	1PB-E6194-00	12 - 21	2SU-E8540-00	14 - 1	2WB-F174K-40	18 - 58	1VP-F41B1-00	22 - 11
1VP-E1191-20	1 - 10	1VP-E3993-00	22 - 10	1FD-E6321-00	12 - 17	5TP-E8542-00	14 - 5	2WB-F174K-50	18 - 58	1DY-F4491-00	22 - 4
1FC-E1193-00	1 - 13	1ST-E4137-00	6 - 11	1FD-E6324-00	12 - 15	1DY-E8545-00	13 - 21	1S8-F175C-00	30 - 23	1DY-F4610-00	22 - 8
4YS-E1198-00	5 - 4	2SU-E4147-00	6 - 8	1PB-E6333-00	12 - 20	31B-E8561-00	13 - 22	3XL-F178A-00	19 - 9	4YY-F4612-00	22 - 9
2SU-E1310-00	1 - 21	2SU-E41A1-00	6 - 9	5HV-E6346-00	15 - 9	31B-E8563-00	13 - 30	1VP-F194J-00	29 - 43	1VP-F470F-00	23 - 2
1DY-E1351-00	1 - 22	2SU-E4411-00	6 - 14	1FD-E6350-00	12 - 16	1DY-E8699-00	15 - 22	1VP-F1978-00	23 - 28	5P2-F4724-00	23 - 5
1VP-E1422-00	2 - 5	1DY-E4412-00	6 - 16	1FD-E6351-00	12 - 19	1VP-F1110-00	16 - 1	1VP-F2100-00-WN	19 - 1	31D-F4726-00	23 - 6
1DY-E1603-10	2 - 11	1DY-E4425-00	6 - 25	16S-E6356-00	12 - 26	1VP-F117R-00	16 - 10	4UL-F2123-00	19 - 2	2WB-F4727-00	23 - 8
1DY-E1605-10	2 - 11	1DY-E4426-00	6 - 26	5YP-E6356-00	12 - 26	5TF-F139R-00	16 - 9	5LM-F2141-00	19 - 4	1VP-F4730-00	23 - 1
1DY-E1607-10	2 - 11	4ST-E443E-00	6 - 21	1FC-E6357-00	12 - 25	2SU-F139U-00	16 - 11	1VP-F2151-00	19 - 3	1VP-F473R-00	23 - 9
1DY-E1631-10	2 - 8	5D9-E443G-00	6 - 23	5D9-E6357-00	12 - 25	1VP-F1511-00-7M	17 - 1	1VP-F2210-00	19 - 11	1VP-F473T-00	23 - 12
1FC-E1633-00	2 - 9	1DY-E4452-00	6 - 19	1FD-E6371-00	12 - 14	1VP-F1511-00-P4	17 - 1	31D-F2277-00	19 - 13	1VP-F4741-00	23 - 4
1DY-E1636-09	2 - 8	2SU-E4453-00	6 - 17	1FD-E6383-00	12 - 18	1VP-F1511-00-P7	17 - 1	1VP-F2311-00	19 - 7	1VP-F4741-10	23 - 3
1DY-E1638-09	2 - 8	1DY-E4462-00	6 - 18	5LM-E6512-00	12 - 6	15K-F1518-00	17 - 7	31D-F3100-30	21 - 1	1S8-F4768-00	23 - 25
1DY-E1651-00	2 - 4	1VP-E4611-00	7 - 1	5D9-E6586-00	12 - 7	1VP-F1556-00	17 - 2	31B-F3110-00	21 - 8	1VP-F4773-00-P2	23 - 26
1DY-E1681-00	2 - 2	10C-E4613-00	7 - 20	1VP-E6611-10	12 - 2	31D-F1568-30	30 - 19	5D9-F3111-00	21 - 16	1VP-F4773-00-P4	23 - 26
2BL-E2111-00	3 - 1	2WB-E4711-00	7 - 2	1VP-E6620-10	12 - 3	1VP-F1611-00	17 - 9	31D-F3126-00	21 - 2	1VP-F4773-00-P7	23 - 26
1DY-E2113-00	3 - 4	44D-E4714-00	7 - 9	1DY-E6626-00	12 - 4	2WB-F1668-00	19 - 10	31D-F3136-10	21 - 5	5P1-F4780-01	23 - 21
54S-E2117-00	3 - 6	44P-E4715-00	7 - 12	1PB-E6628-00	12 - 22	1VP-F1711-00	18 - 1	31B-F313B-00	30 - 6	1VP-F478E-00	23 - 23
5TL-E2118-00	3 - 5	1VP-E4718-00	7 - 6	1DY-E7121-00	13 - 6	1VP-F171E-00-7M	18 - 10	31B-F3141-00	21 - 15	1VP-F4796-00	23 - 29
54P-E2119-00	3 - 3	1VP-E4728-00	7 - 3	1DY-E7121-10	13 - 6	1VP-F171E-00-P0	18 - 10	5LL-F3144-00	21 - 14	1S8-F5168-00-0X	24 - 1
54S-E2121-00	3 - 2	29B-E4747-00	7 - 15	1DY-E7131-00	13 - 2	1VP-F1721-00	18 - 3	4UV-F3145-00	21 - 3	3AY-F5181-01	24 - 8
5P0-E2126-00	3 - 7		29 - 41	1DY-E7141-00	13 - 3	1VP-F172A-00-7M	18 - 14		21 - 6	1VP-F5190-00	24 - 11
54P-E2146-00	3 - 12	31B-E5113-00	9 - 9	1DY-E7211-00	13 - 18	1VP-F172A-00-P0	18 - 14	2JG-F3147-00	21 - 17	31D-F530K-00	26 - 9
2BL-E2151-00	3 - 8	1VP-E5150-00	8 - 1	1DY-E7211-10	13 - 18	1VP-F172F-00-7M	18 - 16	31D-F3152-00	21 - 11	31D-F5321-00	26 - 7
33S-E2159-01	3 - 10	16S-E5155-00	8 - 5	1DY-E7231-00	13 - 17	1VP-F172F-00-P0	18 - 16	5P0-F3153-00	21 - 18	1S8-F5338-00-0X	26 - 1
33S-E2159-10	3 - 10	5D9-E5362-10	9 - 18	1FD-E7241-00	13 - 16	1VP-F172G-00	18 - 38	5P0-F3156-00	21 - 4	31D-F533A-00	26 - 13
1VP-E2170-00	4 - 1	4ST-E5371-00	8 - 2	1DY-E7402-10	13 - 13	1VP-F172H-00	18 - 45		21 - 7	31D-F5351-00	26 - 15
1DY-E2176-00	4 - 6	5VT-E5371-00	8 - 2	1DY-E7411-00	13 - 1	1VP-F1731-00-7M	18 - 6	2JG-F3157-00	21 - 10	31D-F5355-00	26 - 12
2SU-E2210-00	4 - 10	16S-E5377-01	9 - 12	1DY-E7451-00	13 - 27	1VP-F1731-00-P0	18 - 6	509-F3158-L0	21 - 12	1VP-F5364-00	26 - 6
2SU-E2213-00	4 - 11	1VP-E5411-00	9 - 1	1DY-E7456-00	13 - 28	2WB-F173E-30	18 - 53	31D-F3170-00	21 - 9	1VP-F5366-00	26 - 18
1DR-E2228-00	4 - 13	1VP-E5418-00	9 - 10	3C1-E7471-00	13 - 11	2WB-F173E-40	18 - 53	278-F3181-50	21 - 13	31D-F5371-00	26 - 39
54P-E2228-00	4 - 13	1VP-E5421-00	9 - 13	1DY-E8101-00	15 - 1	2WB-F173E-50	18 - 53	1VP-F331A-00	20 - 20	31D-F5373-00	26 - 45
54P-E2231-00	4 - 8	1DY-E5451-00	9 - 2	1VP-E8110-00	15 - 23	2WB-F173F-30	18 - 54	5TF-F331E-00	20 - 17	3XA-F5381-01	26 - 28

NUMERICAL INDEX

PART NO.	REF. NO.	PART NO.	REF. NO.	PART NO.	REF. NO.	PART NO.	REF. NO.	PART NO.	REF. NO.	PART NO.	REF. NO.
5LL-F5383-00	26 - 31	5TF-F7314-00	29 - 36	10C-F8415-10	23 - 10	5LW-H3518-00	34 - 2	90111-08853	25 - 2	90201-06882	18 - 36
5TF-F5389-00	26 - 33	1VP-F7411-00	29 - 18	1VP-F842N-00	30 - 17	1VP-H353F-00	34 - 6	90113-14800	1 - 7	90201-08043	7 - 11
5LL-F539F-00	26 - 34	5LL-F7413-00	29 - 20	1VP-F842N-00	31 - 4	1VP-H3550-00	34 - 14	90116-08843	8 - 10		16 - 5
31D-F5412-00	26 - 23	1DY-F7414-00	18 - 12	1DY-H1410-00	31 - 1	1VP-H357E-00	34 - 12	90119-05022	39 - 19	90201-08057	29 - 30
1VP-F5441-00	26 - 22	1VP-F7430-00	29 - 21	1DY-H1450-00	31 - 2	52B-H3591-00	39 - 6	90119-06117	19 - 8		29 - 40
5P0-F5802-00	25 - 4	5TF-F7433-00	29 - 22	2BR-H1554-00	33 - 7	1VP-H3645-00	34 - 8	90119-06810	6 - 28	90201-08116	7 - 14
5YP-F5803-50	25 - 5	1VP-F7440-00	29 - 31		36 - 7	5VV-H3922-10	37 - 3	90119-068B7	17 - 10	90201-08117	7 - 17
5D9-F5805-01	25 - 9	5TF-F7444-00	29 - 32	1DY-H1800-00	32 - 1	1DY-H3973-00	37 - 1	90149-06159	14 - 3	90201-081J7	26 - 42
31B-F580U-03	25 - 3	5BU-F7445-00	29 - 23	5TP-H1801-00	32 - 2	1DY-H3976-00	37 - 2	90149-06309	38 - 9	90201-088C4	27 - 4
5P0-F5827-00	25 - 14		29 - 33	5D9-H1828-00	32 - 5	1DY-H3980-10	37 - 6	90159-06067	18 - 15	90201-10035	16 - 6
31D-F582U-00	25 - 1	5TF-F8100-00	23 - 30	1DY-H183G-00	32 - 3	1VP-H4140-00	33 - 5		18 - 17	90201-10118	28 - 3
5P0-F583T-13	28 - 4	1VP-F815P-00	27 - 30	5D9-H1861-00	32 - 4	1VP-H4147-00	33 - 3		18 - 20	90201-101J1	24 - 10
5P0-F5852-10	28 - 7	5D9-F8217-00	27 - 5	5TP-H1940-00	39 - 11	1VP-H4310-00	35 - 1		18 - 30	90201-12028	19 - 5
5P0-F5854-00	28 - 6	5D9-F8227-00	27 - 6	1FC-H1960-00	39 - 9	1VP-H4314-00	35 - 2		30 - 2	90201-122H1	31 - 8
5P0-F5855-00	28 - 10	1VP-F8311-00-7M	30 - 1	1PB-H1965-00	39 - 12	31D-H4374-00	35 - 6		30 - 12	90201-127F4	15 - 10
5TL-F5867-11	28 - 9	1VP-F8311-00-P4	30 - 1	10C-H2100-02	38 - 4	1VP-H4397-00	35 - 3	90159-06810	18 - 11	90201-12820	12 - 10
1DY-F5872-00	28 - 1	1VP-F8311-00-P6	30 - 1	2WB-H2115-00	38 - 5	1VP-H4702-00	36 - 13	90170-05803	3 - 9	90201-12824	15 - 14
1VP-F5875-00	20 - 15	1VP-F8312-00	30 - 11	1VP-H2116-10	38 - 7	1VP-H4710-00	36 - 1	90170-06184	26 - 36	90201-12833	26 - 30
1VP-F5886-00	20 - 14	1DY-F8321-00	18 - 24	1VP-H2131-00	23 - 20	1VP-H4714-00	36 - 2	90179-06835	29 - 11	90201-15700	13 - 7
5YP-F5917-00	25 - 6		18 - 33	31D-H2131-00	23 - 19	1VP-H4721-00	36 - 4	90179-08518	1 - 16		13 - 19
5P0-F5919-01	25 - 11	2WB-F8349-00	30 - 16	1VP-H2151-00	38 - 6	1VP-H4723-00	36 - 5	90179-08639	26 - 25	90201-167P7	12 - 5
5YP-F5924-00	25 - 12	5PV-F836D-00	18 - 52	1DY-H2310-00	38 - 1	1VP-H4743-00	36 - 3	90179-08818	16 - 7	90201-178D3	15 - 21
5YP-F5925-01	25 - 10	1VP-F836K-00	30 - 7	1LB-H2370-00	38 - 3	1VP-H4762-00	33 - 8	90179-10024	16 - 8	90201-19801	11 - 5
5YP-F5937-00	25 - 7	1VP-F836L-00	30 - 9	1VP-H252E-00	38 - 8	1CJ-H5111-00	17 - 14	90179-10803	10 - 12	90202-10800	26 - 41
5YP-F5939-00	25 - 13	2WB-F836T-00	30 - 21	1FD-H2530-00	38 - 10	54P-H5130-00	17 - 13	90179-12802	12 - 11	90206-14093	26 - 14
1VP-F6143-00	27 - 7	2WB-F836U-00	30 - 22	1DY-H2540-00	39 - 3	2SU-H5546-00	39 - 2	90179-14001	12 - 24	90206-19802	10 - 10
1VP-F6145-00	27 - 13	2WB-F8371-00	30 - 20	2WB-H2590-00	38 - 11	1DY-H5752-00	39 - 16	90179-25033	20 - 8	90209-17285	13 - 4
1VP-F6210-00	27 - 1	5LL-F8371-00	17 - 8	1VP-H3310-00	33 - 1	5BU-H5753-01	39 - 18	90183-05807	17 - 5	90209-18208	13 - 14
1VP-F6216-00-7M	27 - 17	1VP-F8385-00	18 - 19	1VP-H3311-00	33 - 4	5BU-H5757-00	39 - 17		18 - 7	90240-08145	29 - 24
1VP-F6216-00-P4	27 - 17	2WB-F8391-30	30 - 24		33 - 12	2WB-H591A-00	39 - 1		18 - 9		29 - 34
1VP-F6216-00-P7	27 - 17	2WB-F8391-40	30 - 24		33 - 16	2BM-H592A-00	39 - 8		18 - 18	90249-12008	29 - 10
1VP-F622F-00	18 - 44	2WB-F8391-50	30 - 24	1VP-H3318-00	33 - 18	5P0-W0041-00	28 - 5		18 - 21	90269-06812	18 - 23
	18 - 51	2WB-F8392-30	30 - 25	1VP-H3320-00	33 - 2	4C9-W0048-00	25 - 8		18 - 31		18 - 40
3YR-F622F-00	18 - 5	2WB-F8392-40	30 - 25	1VP-H3330-00	33 - 10	1VP-WE140-10	2 - 1		23 - 11		18 - 47
1VP-F6240-00	27 - 20	2WB-F8392-50	30 - 25	1VP-H3333-00	33 - 13	1DY-WE445-00	6 - 15		27 - 11	90280-03017	2 - 7
1VP-F6241-00	27 - 21	1VP-F8395-00	18 - 29		33 - 17	90101-08847	26 - 24		27 - 16	90340-12808	5 - 3
1VB-F6246-00	27 - 26	2WB-F8398-30	30 - 26	1VP-H333A-00	33 - 11	90105-06893	9 - 4		27 - 19	90340-14812	9 - 7
2WB-F6280-00	27 - 22	2WB-F8398-40	30 - 26	1VP-H3340-00	33 - 14	90105-088D9	16 - 4		30 - 4	90387-06803	6 - 27
5P2-F6282-00	27 - 28	2WB-F8398-50	30 - 26	1VP-H334A-00	33 - 15	90105-088E0	16 - 2		30 - 15	90387-06841	18 - 25
2WB-F6290-00	27 - 23	2WB-F8399-30	30 - 27	1VP-H3358-00	34 - 7	90105-088E1	4 - 5		34 - 13		18 - 34
1VP-F6301-00	27 - 24	2WB-F8399-40	30 - 27	55C-H3365-00	36 - 8	90105-10824	25 - 15	90183-05815	36 - 11	90387-06857	17 - 3
1VP-F7111-00	29 - 1	2WB-F8399-50	30 - 27	1VP-H3371-00	39 - 14	90105-10864	20 - 12	90185-10091	24 - 9		20 - 10
31D-F7112-00	29 - 3	2WB-F839A-00	30 - 28	1VP-H3509-00	34 - 9	90105-10878	19 - 12	90185-10815	20 - 13	90387-068D7	23 - 15
31D-F7114-00	29 - 2	2WB-F839A-10	30 - 28	2WB-H3510-00	34 - 1	90109-06577	37 - 4	90185-12046	26 - 29	90387-068L6	18 - 43
31D-F7211-00	29 - 6	2WB-F839A-20	30 - 28	1VP-H3511-00	34 - 5	90109-08828	26 - 40	90201-06033	23 - 18		18 - 50
5D9-F7231-00	29 - 8	2WB-F839E-00	30 - 29	1DY-H3514-00	31 - 5	90109-08850	29 - 15		36 - 9	90387-07819	17 - 12
1VP-F7311-00	29 - 14	2WB-F839E-10	30 - 29	1VP-H3517-00	34 - 4	90110-05801	5 - 2	90201-06078	7 - 8	90387-08830	7 - 16
5TF-F7314-00	29 - 26	2WB-F839E-20	30 - 29	5BU-H3517-00	34 - 3	90110-06868	1 - 20	90201-06882	18 - 27		29 - 42

NUMERICAL INDEX

PART NO.	REF. NO.	PART NO.	REF. NO.	PART NO.	REF. NO.	PART NO.	REF. NO.	PART NO.	REF. NO.	PART NO.	REF. NO.
90387-10277	24 - 7	91312-05010	13 - 29	93306-204XM	13 - 25	95302-14600	1 - 9	97707-50012	27 - 14		
90387-127Y0	26 - 19		22 - 5	93306-252XR	13 - 10	95304-08700	26 - 43	97707-50016	18 - 4		
90387-12849	26 - 32	91312-06012	11 - 7	93306-252XR	24 - 4	95307-06600	26 - 17		18 - 39		
90387-15817	13 - 23		13 - 12	93306-301YM	26 - 4		26 - 35		18 - 46		
90387-16814	12 - 1	91312-06016	31 - 6	93306-301YN	26 - 3	95604-12200	19 - 6		27 - 10		
90387-20810	12 - 12	91312-06020	6 - 3	93306-305XA	2 - 6	95607-06100	37 - 5		27 - 15		
90401-10159	28 - 2	91312-06025	28 - 11	93310-419X6	11 - 4	95612-08625	1 - 6		27 - 18		
90430-06817	1 - 5		31 - 3	93310-528YA	2 - 3	95702-06500	15 - 19		30 - 3		
90430-10804	39 - 7	91312-08020	15 - 25	93340-212Y2	15 - 11		17 - 15		30 - 14		
90430-14043	1 - 8		29 - 28	93410-20038	13 - 5		23 - 7	98502-05010	23 - 24		
90462-08800	1 - 14		29 - 38	93410-22039	13 - 15	95702-08500	7 - 18	98502-05016	39 - 5		
90462-08818	8 - 11	91312-08035	7 - 10	93440-10085	1 - 3	95702-12500	31 - 7	98502-05025	27 - 29		
90464-24803	27 - 27		29 - 29	93450-14088	2 - 10	95802-06012	20 - 21	98507-06012	23 - 22		
90464-36800	38 - 14		29 - 39	93503-16807	12 - 27		35 - 4	98907-05020	18 - 41		
90465-13152	38 - 13	91401-20012	26 - 44	93604-10801	15 - 12	95802-06016	9 - 11		18 - 48		
90467-110A3	6 - 22		29 - 12	93604-12831	14 - 4	95802-08012	39 - 15	98980-06012	7 - 4		
90467-12802	6 - 24	91401-25015	29 - 25	93606-10800	12 - 8	95802-08040	7 - 13	99009-15400	13 - 8		
90467-13808	6 - 29		29 - 35	93608-34800	11 - 2	95812-06025	6 - 12		13 - 20		
	8 - 4	91401-30030	29 - 4	93608-50149	15 - 6	95812-06030	1 - 11	99009-17400	15 - 20		
90468-23194	10 - 3	91810-14809	1 - 19	93900-00817	24 - 6	95812-10120	16 - 3	99009-19400	10 - 6		
90480-01559	29 - 27		8 - 6		26 - 27	95822-06020	17 - 4				
90480-12808	18 - 42		8 - 9	94107-17872	24 - 5		23 - 27				
	18 - 49		9 - 3	94108-17867	26 - 26	95822-08016	29 - 19				
90480-13398	29 - 37		9 - 15	94568-E1107	26 - 37		29 - 44				
90480-13815	18 - 26	92012-05016	27 - 25	94568-H5090	4 - 7	95822-08045	7 - 19				
	18 - 35	92902-06600	29 - 13	94668-84001	26 - 38	97002-06020	18 - 28				
90480-14806	23 - 14	93101-10804	9 - 20	94700-00372	1 - 17		18 - 37				
90480-18809	36 - 12	93101-10843	9 - 20	95022-06010	1 - 4	97002-08016	27 - 3				
90501-04805	12 - 9	93102-12891	15 - 5		20 - 16	97027-06016	17 - 11				
90501-06022	14 - 6	93102-16801	10 - 13	95022-06012	1 - 15	97027-06035	26 - 16				
90501-06800	14 - 10	93102-20892	13 - 26	95022-06014	38 - 12	97522-06514	36 - 14				
90501-10245	29 - 9	93106-20816	24 - 3		39 - 10	97702-30012	34 - 10				
90501-125E9	15 - 13	93106-26815	26 - 20	95022-06016	20 - 9	97702-40012	34 - 11				
90506-12001	26 - 10	93210-068F7	15 - 18	95022-06020	4 - 12	97702-40512	33 - 6				
90506-15001	26 - 11	93210-12801	4 - 2		5 - 9	97702-50012	17 - 6				
90506-23810	29 - 17	93210-14104	26 - 8		6 - 5	97702-50014	36 - 10				
90506-35806	29 - 5	93210-148F8	9 - 8	95022-06025	20 - 18	97702-50016	18 - 2				
90508-26808	10 - 7	93210-19804	9 - 19		23 - 17		18 - 22				
90508-26815	14 - 8	93210-21800	39 - 4	95022-06035	23 - 16		18 - 32				
90508-40810	29 - 7	93210-29803	32 - 6	95022-06040	8 - 8		23 - 13				
90520-02826	22 - 15	93210-30611	6 - 2		9 - 16		30 - 8				
90520-05813	22 - 13	93210-41041	26 - 5	95022-06050	9 - 5		30 - 10				
90520-06807	18 - 13	93210-60800	5 - 11		9 - 17		30 - 13				
90520-20811	27 - 12	93306-002YE	13 - 24	95022-06055	8 - 7		30 - 18				
90520-25802	27 - 2	93306-002YW	4 - 3	95022-06060	9 - 6		33 - 9				
	27 - 8	93306-004XB	26 - 21	95022-06100	5 - 10	97702-50030	6 - 20				
90560-10292	24 - 2	93306-054X1	13 - 9	95023-06016	38 - 2	97707-40616	36 - 6				
90560-12145	26 - 2	93306-054Y2	13 - 9	95302-08700	29 - 16	97707-50012	27 - 9				